

RD172

Dana 70/80,35 SPL,Low Speed

PARTS LIST

| ITEM # | QTY | DESCRIPTION | PART # | NOTES |
|--------|-----|-----------------------------------|--------------|-------|
| 1 | 2 | TAPERED ROLLER BEARINGS | NOT SUPPLIED | |
| 2 | 1 | SEAL HOUSING O-RINGS (PK OF 2) | 160251SP | 1 |
| 3 | 1 | SEAL HOUSING KIT | 082107SP | 3 |
| 4 | 1 | SEAL HOUSING BRACKET | 220212 | |
| 5 | 1 | FLANGE CAP KIT | 028618SP | 3 |
| 6 | 4 | PINION GEAR THRUST WASHER | SEE NOTE | 4 |
| 7 | 4 | PINION GEAR | SEE NOTE | 2 |
| 8 | 1 | SPLINED SIDE GEAR | SEE NOTE | 2 |
| 9 | 1 | SPIDER BLOCK | 070402SP | |
| 10 | 1 | SIDE GEAR | SEE NOTE | 2 |
| 11 | 2 | SIDE GEAR THRUST WASHER | SEE NOTE | 4 |
| 12 | 1 | DIFFERENTIAL CASE | 013218SP | 3 |
| 13 | 1 | RETAINING PIN SET (PK OF 4) | 120601SP | |
| 14 | 1 | COUNTERSUNK SCREW (PK OF 2) | 200214SP | |
| 15 | 2 | MASTER SHIM (OD Ø104.5) | 150357 | |
| * | 2 | MASTER SHIM (OD Ø95.8) | 150331 | |
| 16 | 1 | BONDED SEAL | 160706SP | |
| 17 | 1 | CLUTCH GEAR & WAVESPRING KIT | 050909SP | |
| 18 | 1 | WAVESPRING | 150705SP | |
| 19 | 2 | SHORT CROSS SHAFT | 061601SP | |
| 20 | 1 | LONG CROSS SHAFT | 061501SP | |
| * | 1 | SHIM KIT (OD Ø104.5) | SHK006 | |
| * | 1 | SHIM KIT (OD Ø95.8) | SHK001 | |
| * | 1 | BULKHEAD FITTING KIT (BANJO TYPE) | 170114 | 5 |
| * | 1 | AIR LINE (6mm DIA X 6m LONG) | 170314 | 5 |
| * | 1 | SOLENOID VALVE (12V) | 180103 | |
| * | 1 | SWITCH | 180209SP | |
| * | 1 | SWITCH COVER (FRONT) | 180210SP | |
| * | 1 | SWITCH COVER (REAR) | 180211SP | |
| * | 1 | CABLE TIE (PK OF 25) | 180305 | |
| * | 1 | OPERATING & SERVICE MANUAL | 210200 | |
| * | 1 | INSTALLATION GUIDE | 2102172 | |

* *Not illustrated in exploded view*

NOTES

- 1 For replacement O-rings use only BS149 Viton 75.
- 2 Available only as complete 6 gear set # 728K041
- 3 Diffs built pre June 2014 (serial numbers before 14060001) have 082106 Seal Housing, 013214 Case, and 028614 Flange Cap.
- 4 Available only as complete thrust washer kit #730K01
- 5 All diffs produced before serial #17070001 came with 5mm air connection system. For information contact ARB.
- For High Speed ratios please refer to RD173 ([Section 2.173](#))

RD172

Dana 70/80,35 SPL,Low Speed

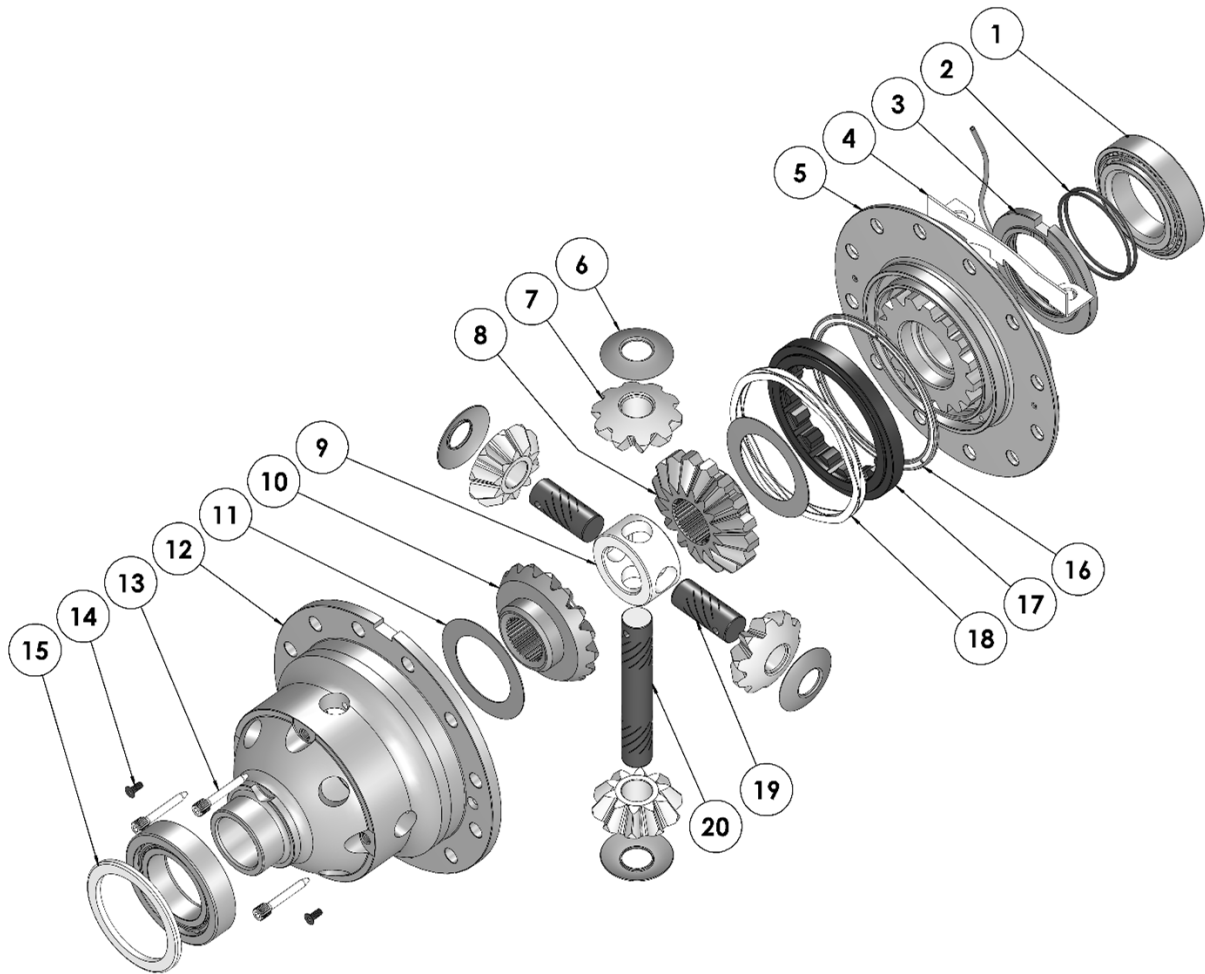
EXPLODED DIAGRAM**SPECIFICATIONS**

| | |
|--------------------|----------------------------|
| Axle Spline | 35 tooth, Ø38.1mm [1.50"] |
| Ratio Supported | Varies |
| Ring Gear ID | 174.9mm [6.89"] |
| Ring Gear OD | 267mm [10.5"] |
| Ring Gear Bolts | 12 bolts on Ø203mm [8.00"] |
| Ring Gear Torque | 149Nm [110 ft-lb] |
| Backlash | 0.15-0.25mm [0.006-0.010"] |
| Bearing Cap Torque | 108Nm [80 ft-lb] |

ARB Corporation Ltd • 42-44 Garden St Kilsyth VIC 3137 Australia
ARB 4X4 Accessories USA • 720 SW 34th St Renton WA 98057 USA
Australia & International Customer Service • +61 3 9761 6622
North America Customer Service • Toll Free 866 293 9078
www.arb.com.au (AUS & Int) www.arbusa.com (N. America)

