

**RD196**

Nissan C200K, 31 SPL

### PARTS LIST

ITEM #	QTY	DESCRIPTION	PART #	NOTES
1	1	SEAL HOUSING O-RING (PK OF 2)	160235SP	1
2	1	SEAL HOUSING KIT	081818SP	
3	2	SHIM KIT	SHK009	
4	1	BONDED SEAL	160702SP	
5	1	CLUTCH GEAR & WAVESPRING KIT	050906SP	
6	1	SPIDER BLOCK	070201SP	
7	1	LONG CROSS SHAFT	060204SP	
8	1	SIDE GEAR	SEE NOTE	2
9	1	COUNTERSUNK SCREW (PK OF 2)	200213SP	
10	1	RETAINING PIN SET (PK OF 4)	120601SP	
11	2	TAPERED ROLLER BEARING	NOT SUPPLIED	
12	1	FLANGE CAP KIT	027331SP	
13	1	WAVESPRING	150706SP	
14	1	SPLINED SIDE GEAR	SEE NOTE	2
15	2	SHORT CROSS SHAFT	060403SP	
16	4	PINION GEAR	SEE NOTE	2
17	4	PINION THRUST WASHER	SEE NOTE	3
18	2	SIDE GEAR THRUST WASHER	SEE NOTE	3
19	1	DIFFERENTIAL CASE	013031SP	
*	1	BULKHEAD FITTING KIT (BANJO TYPE)	170114	4
*	1	AIR LINE (6mm DIA X 6m LONG)	170314	4
*	1	SOLENOID VALVE (12V)	180103	
*	1	SWITCH	180209SP	
*	1	SWITCH COVER (FRONT)	180210SP	
*	1	SWITCH COVER (REAR)	180211SP	
*	1	CABLE TIE (PK OF 25)	180305	
*	1	OPERATING & SERVICE MANUAL	210200	
*	1	INSTALLATION GUIDE	2102196	

\* *Not illustrated in exploded view*

### NOTES

- 1 For replacement O-rings use only BS133 Viton 75.
- 2 Available only as complete 6 gear set # 728H151
- 3 Available only as complete thrust washer kit #730H01
- 4 All diffs produced before serial #17070001 came with 5mm air connection system. For information contact ARB.
- Refer to pinion modification tech note ([Sec. 5.6](#)).

**RD196**

Nissan C200K, 31 SPL

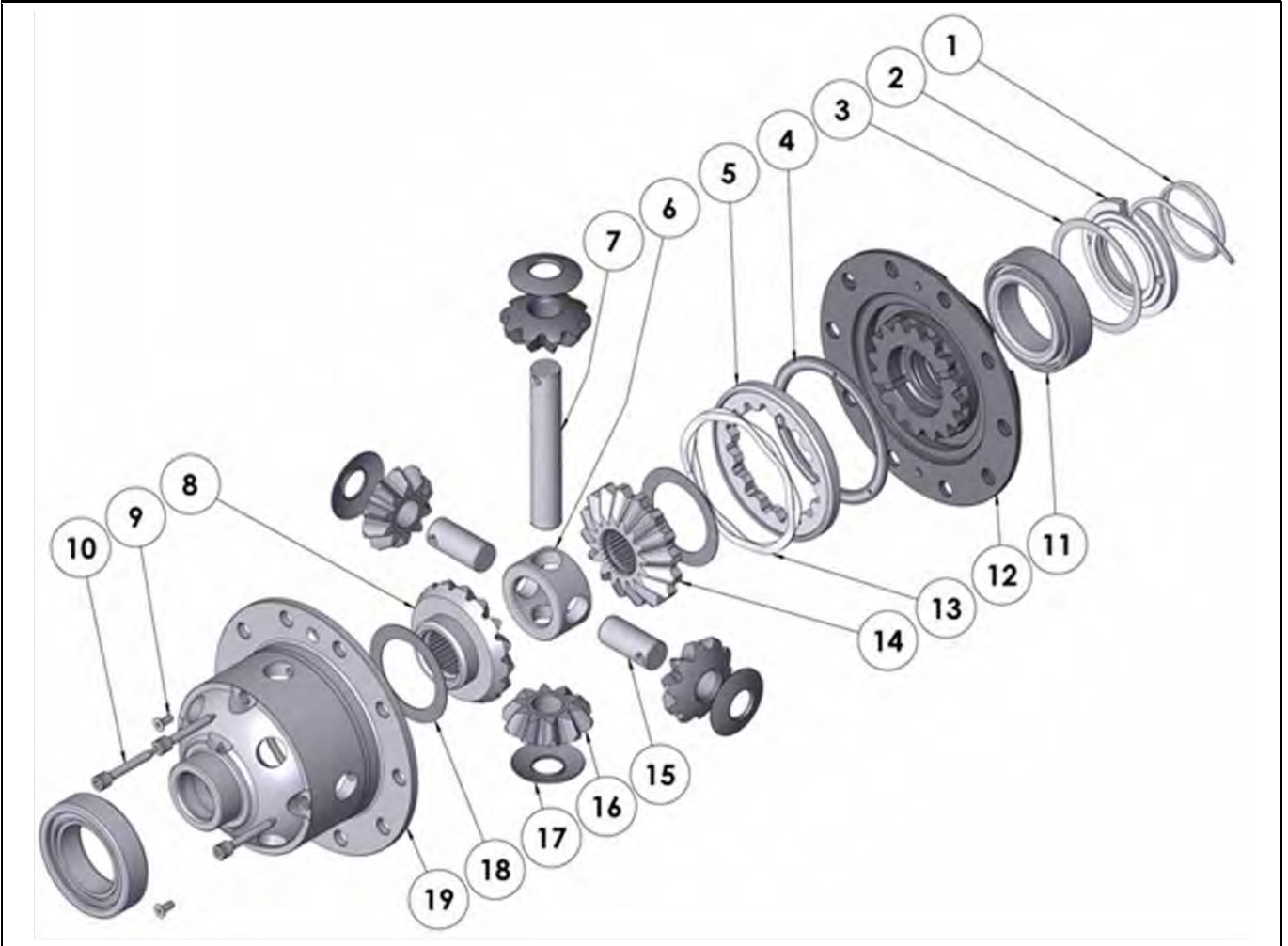
**EXPLODED DIAGRAM****SPECIFICATIONS**

Axle Spline	31 tooth, Ø32mm [1.26"]
Ratio Supported	All
Ring Gear ID	128.0mm [5.03"]
Ring Gear OD	200mm [7.87"]
Ring Gear Bolts	10 bolts on Ø150mm [5.90"]
Ring Gear Torque	149 Nm [110 ft-lb]
Backlash	0.10-0.15mm [0.004-0.006"]
Bearing Cap Torque	94 Nm [70 ft-lb]