

RD216

GM 12 Bolt, 8.9", 30 SPL, 3.73 & UP

PARTS LIST

ITEM #	QTY	DESCRIPTION	PART #	NOTES
01	1	FLANGE CAP KIT	027338SP	
02	1	BONDED SEAL	160702SP	
03	1	CLUTCH GEAR & WAVESPRING KIT	050906SP	
04	1	WAVESPRING	150706SP	
05	1	LONG CROSS SHAFT	060204SP	
06	3	PINION GEAR	SEE NOTE	3
07	3	PINION GEAR THRUST WASHER	SEE NOTE	4
08	1	DIFFERENTIAL CASE	013038SP	
09	---	TAPERED ROLLER BEARING	NOT SUPPLIED	2
10	1	SHIM KIT	SHK008	
11	1	SEAL HOUSING KIT	081802SP	
12	1	SEAL HOUSING O-RINGS (PK OF 2)	160235SP	1
13	1	MASTER SHIM	150320	
14	2	SIDE GEAR THRUST WASHER	SEE NOTE	4
15	1	SPLINED SIDE GEAR	SEE NOTE	3
16	1	SPIDER BLOCK	070902SP	
17	1	SHORT CROSS SHAFT	060403SP	
18	1	SIDE GEAR	SEE NOTE	3
19	1	COUNTERSUNK SCREW (PK OF 2)	200213SP	
20	1	RETAINING PIN SET (PK OF 4)	120601SP	
*	1	C-CLIP KIT	CCK005	
*	1	BULKHEAD FITTING KIT (BANJO TYPE)	170114	5
*	1	AIR LINE (6mm DIA X 6m LONG)	170314SP	5
*	1	SOLENOID VALVE (12V)	180103	
*	1	SWITCH	180209SP	
*	1	SWITCH COVER (REAR)	180211SP	
*	1	CABLE TIE (PK OF 25)	180305	
*	1	OPERATING & SERVICE MANUAL	210200	
*	1	INSTALLATION GUIDE	2102216	

* *Not illustrated in exploded view*

NOTES

- 1 For replacement O-rings use only BS133 Viton 75
- 2 For replacement bearing use Timken part #LM603049 / LM603012.
- 3 Available only as complete 5 gear set #728H181C
- 4 Available only as complete thrust washer kit #730H01
- 5 All diffs produced before serial #17070001 came with 5mm air connection system. For information contact ARB.
- Ring gear bolts are 3/8" - 24 left-hand thread, and must be removed in a clockwise direction.

RD216

GM 12 Bolt, 8.9", 30 SPL, 3.73 & UP

EXPLODED DIAGRAM

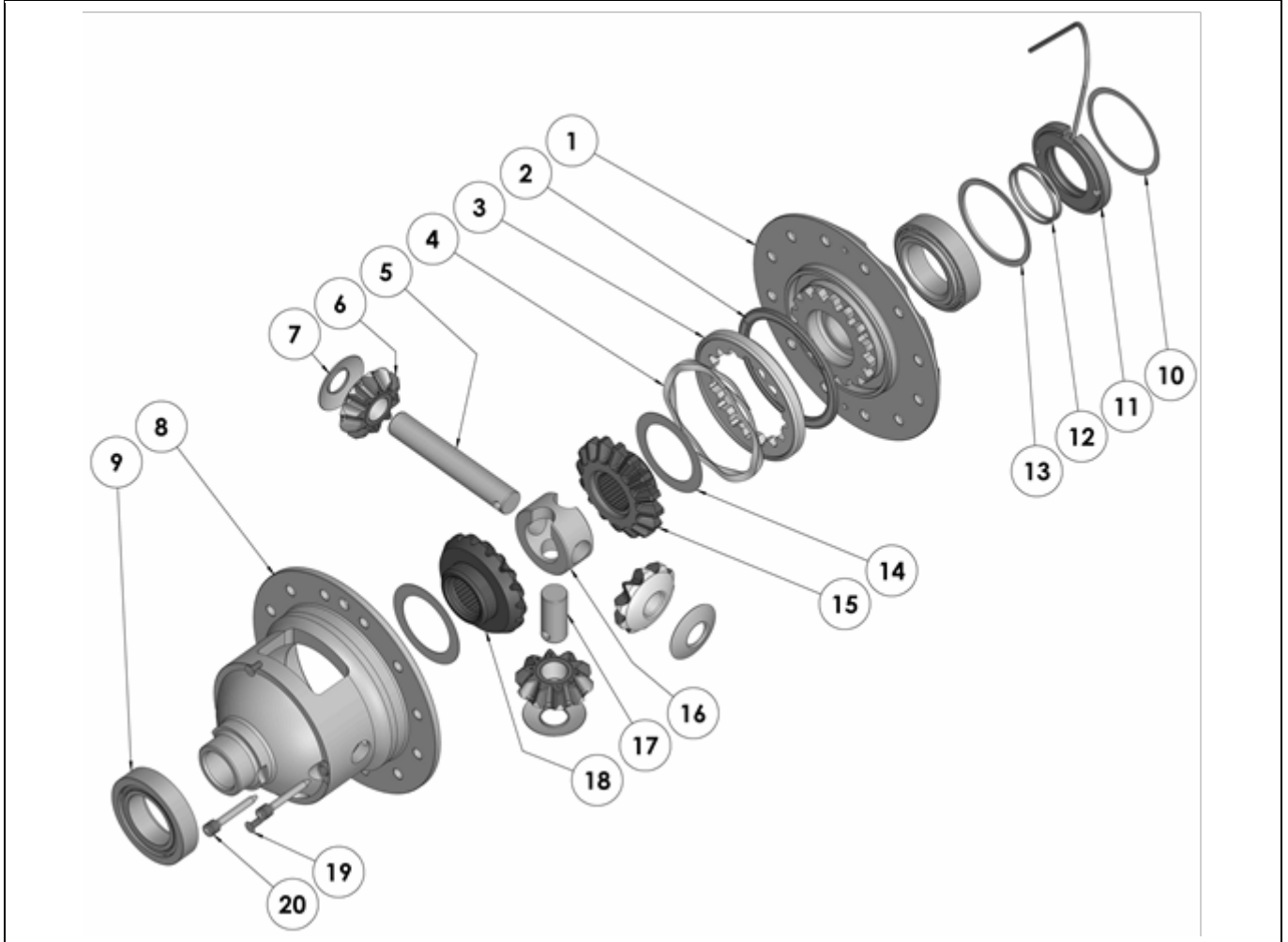

SPECIFICATIONS

Axle Spline	30 tooth, Ø33.3mm [1.31"]
Ratio Supported	3.73:1 & up
Ring Gear ID	138.1mm [5.44"]
Ring Gear OD	225mm [8.9"]
Ring Gear Bolts	12 bolts on Ø165mm [6.50"]
Ring Gear Torque	75Nm [55 ft-lb]
Backlash	0.15-0.25mm [0.006-0.010"]
Bearing Cap Torque	81Nm [60 ft-lb]