

RD82

Ford 8.8",28 SPL

PARTS LIST

ITEM #	QTY	DESCRIPTION	PART #	NOTES
1	1	SEAL HOUSING KIT	081501SP	
2	1	CLUTCH GEAR & WAVESPRNG KIT	050901SP	
3	3	PINION THRUST WASHER	SEE NOTE	4
4	3	PINION GEAR	SEE NOTE	3
5	1	LONG CROSS SHAFT	060204SP	
6	1	SHORT CROSS SHAFT	060403SP	
7	1	DIFFERENTIAL CASE	013001SP	
8	1	COUNTERSUNK SCREW (PK OF 2)	200213SP	
9	1	RETAINING PIN SET (PK OF 4)	120601SP	
10	1	TAPERED ROLLER BEARING	160109	2
11	1	SEAL HOUSING O-RINGS (PK OF 2)	160227SP	1
12	1	FLANGE CAP KIT	028401SP	
13	1	BONDED SEAL	160702SP	
14	1	WAVESPRING	150701SP	
15	1	SPLINED SIDE GEAR	SEE NOTE	3
16	1	SPIDER BLOCK	070902SP	
17	1	SIDE GEAR	SEE NOTE	3
18	2	SIDE GEAR THRUST WASHER	SEE NOTE	4
19	1	TAPERED ROLLER BEARING	NOT SUPPLIED	2
*	1	C-CLIP KIT	CCK005	
*	1	AIR LINE (6mm DIA X 6m LONG)	170314	5
*	1	BULKHEAD FITTING KIT (BANJO TYPE)	170114	5
*	1	SOLENOID VALVE (12V)	180103	
*	1	CABLE TIE (PK OF 25)	180305	
*	1	SWITCH	180209SP	
*	1	SWITCH COVER (REAR)	180211SP	
*	1	OPERATING & SERVICE MANUAL	210200	
*	1	INSTALLATION GUIDE	210282	

* *Not illustrated in exploded view*

NOTES

- 1 For replacement O-rings use only BS138 Viton 75.
- 2 For replacement bearing use Timken part # LM102949 / LM102910.
- 3 Available only as complete 5 gear set #728H041C
- 4 Available only as complete thrust washer kit #730H01
- 5 All diffs produced before serial #17070001 came with 5mm air connection system. For information contact ARB.
- RD82 suits C-clip & non C-clip applications.
- For the 31 spline model see RD81 ([Section 2.81](#)).
- Suitable for use with ABS tone ring.
- Seal housing comes pre-installed.
- To service O-rings or bearing remove the seal housing assembly with a bearing puller.
- Thicker aftermarket ring gears may require modification to remove the cross shaft. Refer to tech note ([Section 5.6](#)).

RD82

Ford 8.8",28 SPL

EXPLODED DIAGRAM

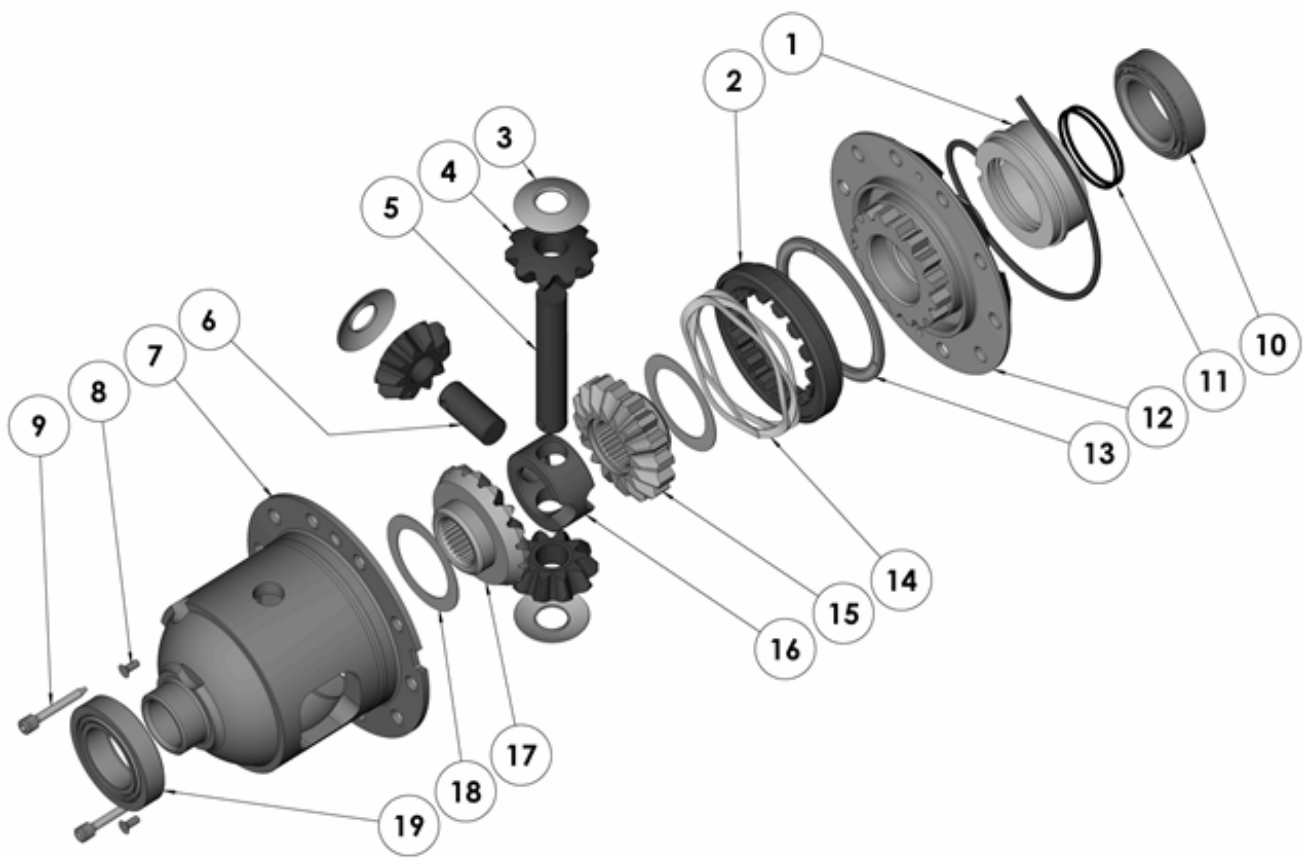

SPECIFICATIONS

Axle Spline	28 tooth, Ø30.5mm [1.20"]
Ratio Supported	All
Ring Gear ID	127.0mm [5.00"]
Ring Gear OD	224mm [8.8"]
Ring Gear Bolts	10 bolts on Ø152mm [6.00"]
Ring Gear Torque	81Nm [60 ft-lb]
Backlash	0.28-0.41mm [0.011-0.016"]
Bearing Cap Torque	81Nm [60 ft-lb]