



ARB WINCH/NONWINCH BULLBAR TO SUIT HJ100 IFS

PRODUCT No. 3413050 (Pre 09/2002)

WARNING

FOR VEHICLES EQUIPPED WITH SRS AIRBAG

**WHEN INSTALLED IN ACCORDANCE WITH THESE INSTRUCTIONS, THE
FRONT**

PROTECTION BAR DOES NOT AFFECT OPERATION OF THE SRS AIRBAG.

TAKE NOTE OF THE FOLLOWING:

- **THIS PRODUCT MUST BE INSTALLED EXACTLY AS PER THESE INSTRUCTIONS USING ONLY THE HARDWARE SUPPLIED.**
- **IN THE EVENT OF DAMAGE TO ANY BULL BAR COMPONENT, CONTACT YOUR NEAREST AUTHORISED ARB STOCKIST. REPAIRS OR MODIFICATIONS TO THE IMPACT ABSORPTION SYSTEM MUST NOT BE ATTEMPTED.**
- **DO NOT USE THIS PRODUCT FOR ANY VEHICLE MAKE OR MODEL, OTHER THAN THOSE SPECIFIED BY ARB.**
- **DO NOT REMOVE LABELS FROM THIS BULL BAR.**
- **THIS PRODUCT OR ITS FIXING MUST NOT BE MODIFIED IN ANY WAY.**

IMPORTANT

- **This bull bar is suitable for Warn 9000lb, 9500lb High Speed, 10000lb, and 12000lb winches. Note: if fitting a 10000lb or 12000lb winch cable kit 6171397 is required.**

Tools Required

10mm, 14mm, 18mm, 19mm, 22mm Spanners and Sockets. Phillips head screwdriver, hacksaw, drill & 10mm drill bit.

Optional Extras suited for this bar includes a range of IPF driving lights and durable driving light covers. Contact your nearest ARB stockist for further information.

USE	PART No	QTY	DESCRIPTION
MOUNT ASSY TO VEHICLE	6151257	2	BOLT M12 X 200mm
	4581049	6	WASHER FLAT
	4721469	2	TUBE PACKER
	5846282	2	CHANNEL PACKER
	4581050	2	WASHER SPRING M12
	6151189	2	NUT M12
	6151258	2	BOLT M14 X 80mm
	4581052	4	WASHER SPRING M14
	5846283	4	PACKER 10mm THICK
	3756202	1	MOUNT ASSY.
BULLBAR TO MOUNT ASSY	6151255	6	BOLT M12 X 40mm
	4581050	6	WASHER SPRING M12
	4581007	6	WASHER FLAT M12 LARGE
	6151045	2	BOLT M10 X 25mm
	4581039	4	WASHER M10 FLAT
	4581048	2	WASHER M10 SPRING
	6151026	2	NUT M10
WINCH	4581040	4	WASHER 3/8"
CONTROL BOX FITTMENT	3756220	1	CONTROL BOX BRACKET
	6151017	2	BOLT M6 X 16MM
	6151128	2	NUT FLANGE M6
	6151046	2	WASHER M6
ROLLER FAIRLEAD FITTMENT	6151255	2	BOLT M12 X 40mm
	4581050	2	WASHER SPRING M12
	4581049	4	WASHER FLAT M12
	6151189	2	NUT M12
WINCH COVER FITTMENT	6151128	2	NUT FLANGE M6
	6151256	2	SCREW M6 S/STEEL BUTTON HEAD
	6191001	1	WINCH COVER EXTRUSION
	6521036	1	WINCH COVER (Pre 09/2002)
	6522018	1	WINCH COVER (09/2002 On)
	6151046	2	WASHER M6
BUFFERS	3500170	1	BUFFER KIT WITH 8 M6 NUTS
NUMBER PLATE FITTMENT	6151017	4	BOLT M6 X 16mm
	6151128	4	NUT FLANGE M6
	3756234	1	BRACKET NUMBER PLATE
	6151046	2	WASHER M6
WIRING	3500080	1	INDICATOR KIT
	180302	6	CABLE TIE

ASSEMBLY SEQUENCE FOR BULLBAR.

1.



1. Remove the bumper bar and grill.
2. Remove the cross member and tow brackets. See picture.
3. Bend the sheet metal returns located under the light area down so they don't interfere when the bar is fitted. Mask under the light trim and guard and paint flat black.
4. Bend the center bracket back approx 90 degrees.

2.



1. Insert the tube packers, one in each chassis arm. Line the bottom of the tube to the bottom hole of the chassis rail. Rest the top of the tube to the front of the chassis rail. The tube should be angled forward.

3.



1. Slide the mount assy. over the chassis rails. Try not to shake the vehicle too severely as the tube packers may fall out of place.
2. Insert the channel packers from the rear. Make sure the hole correspond to the holes in the mount.
3. Push the entire mount as far back as possible.

ASSEMBLY SEQUENCE FOR BULLBAR.

4.



1. Using a long screwdriver insert it through the bottom hole so it passes through the tube packer. This may require a visual check from under the vehicle to see the position of the tube.
2. Using the screwdriver twist around until the packer is inline with the top hole.

5.



1. Insert the M12 X 200mm bolt through the top hole using one of the 10mm thick packers. Push through while removing the screwdriver from underneath until the bolt locates right through.

Note: For turbo diesel models remove the intercooler hose to gain access for the M12 X 200mm bolt.

6.



1. Fasten the remainder of the mount using:
 - 2 M14 bolts removed earlier from tow bracket
 - 2 M14 bolts from fitting kit
 - 6 M14 flat washers
 - 4 M14 spring washers
 - 2 10mm thick packers
 - 2 M12 nuts
 - 2 M12 spring washers

Note: Assemble with the tow brackets.

ASSEMBLY SEQUENCE FOR BULLBAR.

7.

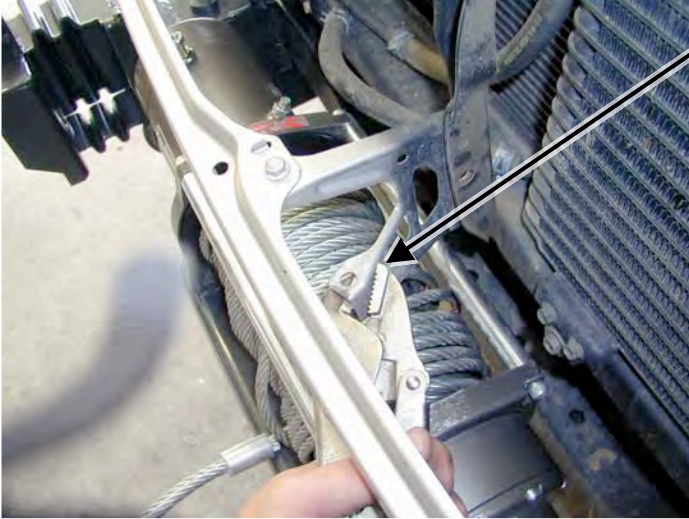

1. For pre 09-2002 models use vice grips, multi grips or pliers bend back the bumper mounting arm approximately 90 degree's to clear winch bumper when assembled.

8.



1. On models built after 09-2002 if you are fitting a 10000lb or 12000lb winch you will need to remove the upright support and cut a section of it out.

9.



1. Once removed hold the upright in a vice and cut out the section shown with a hacksaw.
2. Replace the upright and continue fitting the winch.

ASSEMBLY SEQUENCE FOR BULLBAR.

8.

Viewed from passenger side, gearbox end.

9000lb & H/S 9500lb

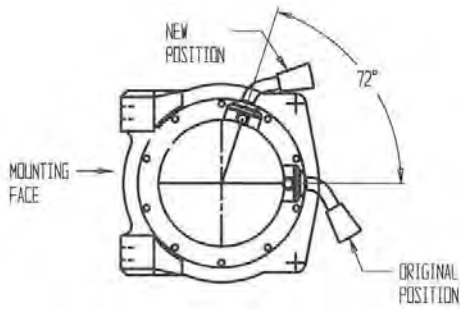

Viewed from passenger side, motor end.

10000lb & 12000lb

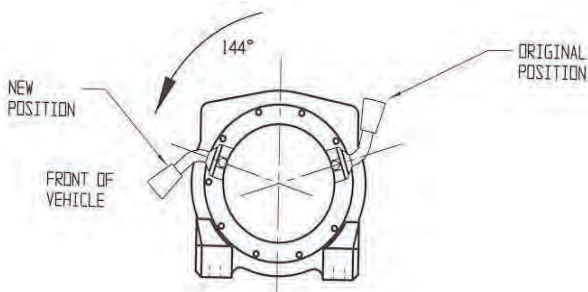

(If fitting with winch)

To place the clutch handle in a convenient location the winch gearbox must be rotated.

1. Place the winch on its end and remove all gearbox bolts.
2. Gently raise the motor just enough to rotate it.
3. Do not completely remove the motor and avoid damaging the gasket.
4. Refit and tighten all bolts.

Note: Take care not to lift the assembly more than a couple of millimeters while rotating to the desired position to avoid unmeshing the gears.

9.

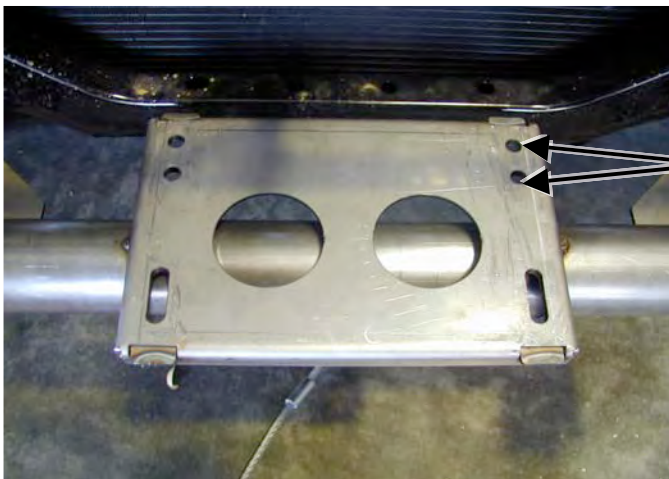

(If fitting with winch.)

1. Place the winch on the mount assembly.
2. Bolt from underneath using bolts supplied with winch and the 3/8" washers supplied in the fitting kit. Refer to Warn installation instructions for correct procedure.

Note: If fitting 9000lb or 9500lb high speed winches mount on the front hole positions. If fitting 10000lb or 12000lb winches mount on the rear hole position. Fasten the two front bolts first then push the winch to the back position. Fasten the two rear bolts then tighten all bolts. Move front lower tie rod to rear lower position for 10000lb and 12000lb winches.

ASSEMBLY SEQUENCE FOR BULLBAR.

10.



(If fitting with winch)

1. Bolt the roller fair lead to the winch bumper using the M12 X 40mm bolts, washers, spring washers and nuts.

11.

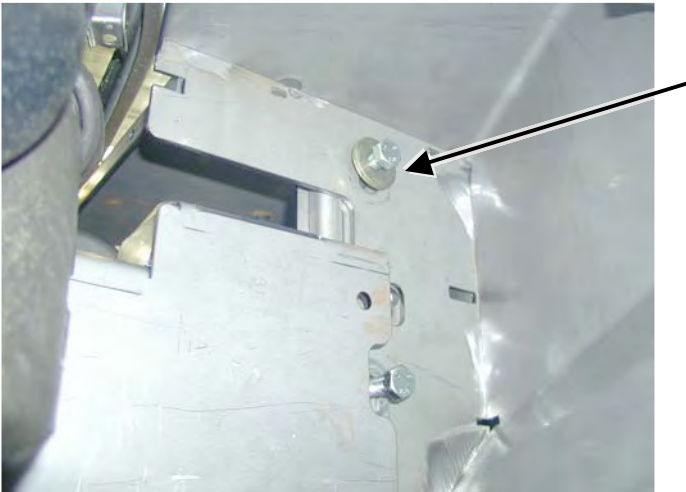

1. Fasten the indicator lights to the bar.
2. Position the bar on the mounts and fasten the bar to the mounts using the M12 X 40mm bolts, large washers and spring washers.
3. Line up the end of the wing to the wheel arch and leave approximately a 15mm gap between the bar and the vehicle. Tighten all bolts.

Note: The lower bolt can be accessed through the cutout at the front of the wing.

12.



(If not fitting winch)

1. Wrap rubber extrusion around winch cover.
2. Place washers over the winch cover fixing holes located on the top middle face of the winch bumper.
3. Place the winch cover on top of the winch bumper inline with the mount holes.
4. Bolt together using the M6 button head stainless steel screws and M6 nuts.

ASSEMBLY SEQUENCE FOR BULLBAR.

13.



1. Next step is to lock pin the bar so there is no movement by drilling a 10mm hole on both sides of vehicle, fasten with 10mm x 25mm bolts plus 10mm hardware.

14.



(If fitting with winch)

1. Feed the winch cable through the roller fair lead. Mount the hook to the end of the cable.

15.



Fitting with winch



Fitting without winch

(If fitting with winch.)

1. Bolt the number plate to the number plate bracket using the M6 bolts and M6 flange nuts.
2. Bolt the assembly to the bar as shown in the illustration using the M6 bolts and M6 flange nuts.

(If not fitting with winch.)

1. Bolt the number plate through the top holes using M6 X 16mm bolts and M6 flange nuts.

ASSEMBLY SEQUENCE FOR BULLBAR.

16.



1. If fitting the **XP 9.5 winch**, remove the cover from the control box.

For any other winch, go to step 22.

17.

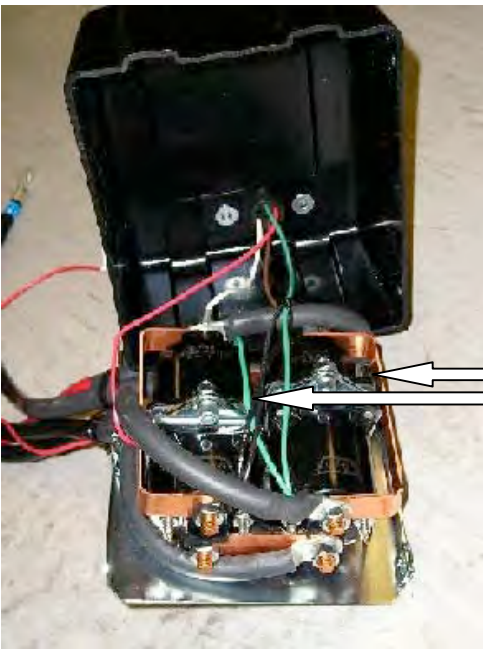

1. Remove the two cap screws, nuts and spacer washers that hold the four solenoids in place.

18.

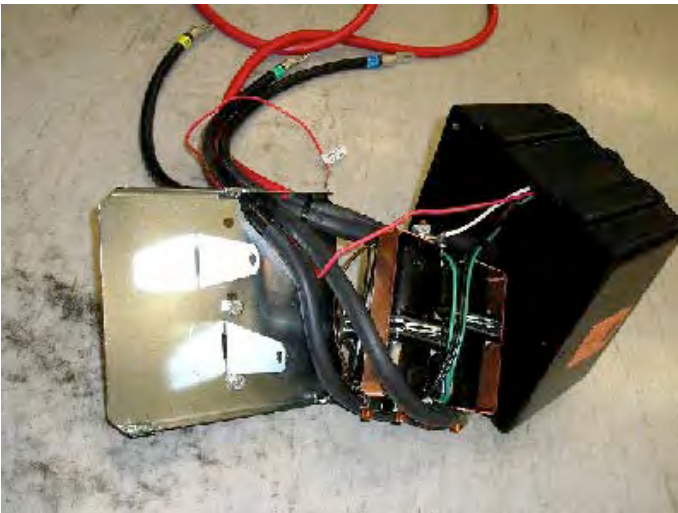

1. Remove the four solenoids from the base of the control box using the copper bus bar as an aid and hold to one side.

ASSEMBLY SEQUENCE FOR BULLBAR.

19.

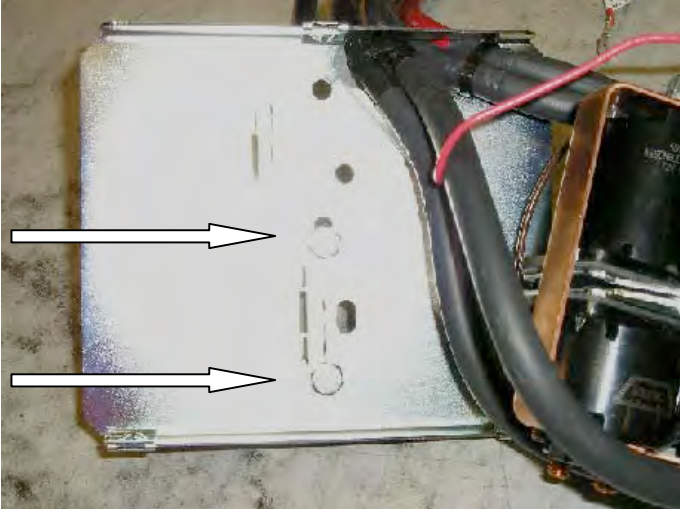

Before

1. Remove the two bolts in the base of the control box and reposition them into the more centralised holes

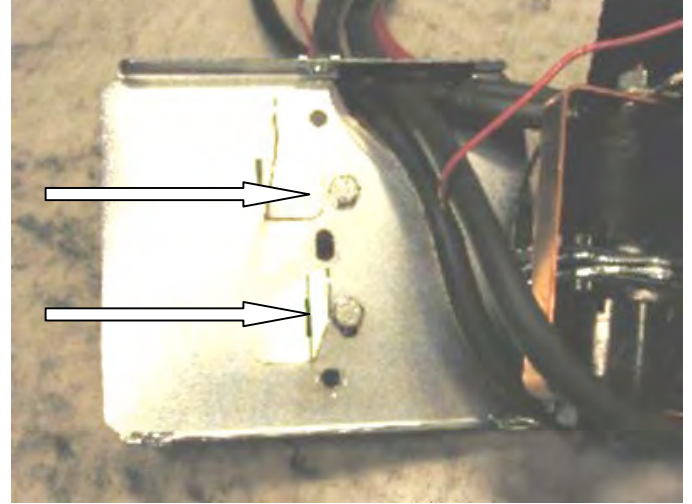

After

20.



1. Place the 4 solenoids over the 2 metal stands that are facing upwards. Make sure they line up with the holes in the base.

21.



1. Replace the 2 cap screws, washers and nuts removed in step 17 above into original holes.
2. Replace the black cover and refit the three cover screws (DO NOT OVER TIGHTEN)

ASSEMBLY SEQUENCE FOR BULLBAR.

22.

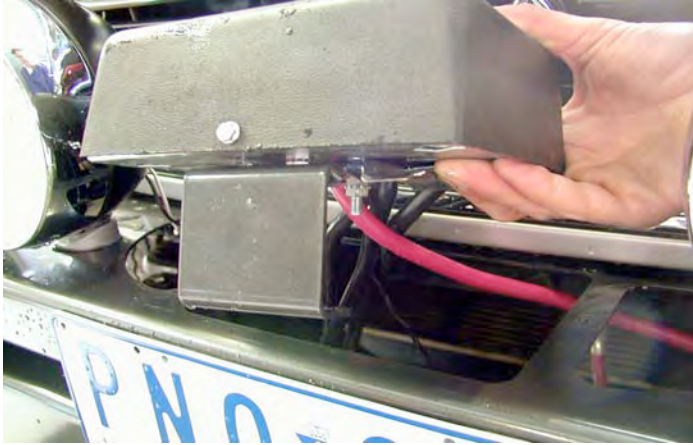

(If fitting with winch)

1. Assemble the control box bracket to the control box using M6 nuts located on the control box bolts.
2. Mount the control box to the bar using M6 X 16 bolts and M6 flange nuts. Fasten the control box to the front of the cutout on the top pan. This should leave an opening at the rear for viewing the cable drum while operating the winch.

Note: If fitting a 10000lb or 12000lb winch cable kit 6171397 is required. Replace the control box cables with the new longer cables.

23.

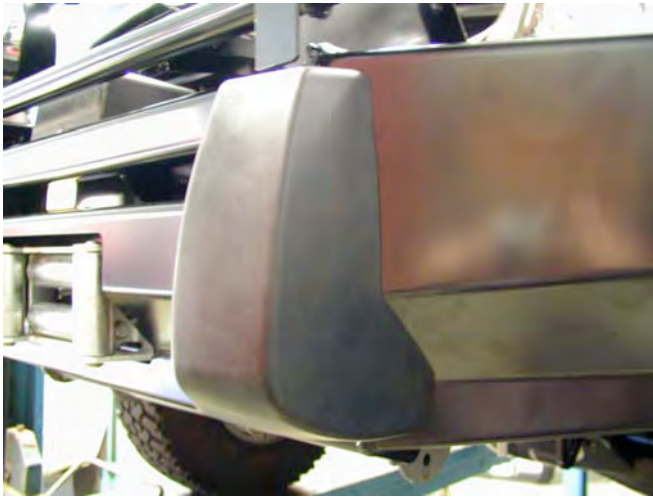

1. Fasten the buffers using the M6 flange nuts supplied.

24.

(If fitting with winch)

Connect the winch control box cables to the winch motor. Refer to the Warn handbook for additional information. Connect the long winch + & - cables to the vehicle after the bar is installed. Refer to the Warn winch manual for vehicle wiring instructions. Note: if fitting a 10000lb or 12000lb winch cable kit 6171397 is required. Use the longer leads to replace ones on control box.

Ensure that these cables are installed well clear of sharp, hot or moving objects. Secure the winch cables to the vehicle and winch bumper with the supplied cable ties.

25.

Wire the turn signal lights to the vehicle wiring.