



FITTING INSTRUCTIONS

Part Number: **3452030**
Product **COMBAR DODGE RAM 2006 ON**
Description: **F/KIT 6172164, 6172147**
Suited to **Models 1500 2006 ON** **ADD BRACKET KIT# 3552030**
vehicle/s: **OR Models 2500/3500 2006 ON** **ADD BRACKET KIT# 3552040**

WARNING

REGARDING VEHICLES EQUIPPED WITH SRS AIRBAG:

When installed in accordance with these instructions, the front protection bar does not affect operation of the SRS airbag.

ALSO, NOTE THE FOLLOWING:

- ◆ This product must be installed exactly as per these instructions using only the hardware supplied.
- ◆ In the event of damage to any bull bar component, contact your nearest authorised ARB stockist. Repairs or modifications to the impact absorption system must not be attempted.
- ◆ Do not use this product for any vehicle make or model, other than those specified by ARB.
- ◆ Do not remove labels from this bull bar.
- ◆ This product or its fixing must not be modified in any way.
- ◆ The installation of this product may require the use of specialized tools and/or techniques
- ◆ It is recommended that this product is only installed by trained personnel
- ◆ These instructions are correct as at the publication date. ARB Corporation Ltd. cannot be held responsible for the impact of any changes subsequently made by the vehicle manufacturer
- ◆ During installation, it is the duty of the installer to check correct operation/clearances of all components
- ◆ Work safely at all times
- ◆ Unless otherwise instructed, tighten fasteners to specified torque

ARB 4x4 ACCESSORIES

Corporate Head Office

42-44 Garden St
Kilsyth, Victoria
AUSTRALIA 3137

Tel: +61 (3) 9761 6622
Fax: +61 (3) 9761 6807

Australian enquiries
North & South American enquiries
Other international enquiries

sales@arb.com.au
sales@arb.com.au
exports@arb.com.au

www.arb.com.au

GENERAL CARE AND MAINTENANCE

By choosing an ARB Bar, you have bought a product that is one of the most sought after 4WD products in the world. Your bar is a properly engineered, reliable, quality accessory that represents excellent value. To keep your bar in original condition it is important to care and maintain it following these recommendations:



- Prior to exposure to the weather your bar should be treated to a Canuba based polish on all exposed surfaces. It is recommended that this is performed on a six monthly basis or following exposure to salt, mud, sand or other contaminants.
- As part of any Pre Trip Preparation, or on an annual basis, it is recommended that a thorough visual inspection of the bar is carried out, making sure that all bolts and other components are torqued to the correct specification. Also check that all wiring sheaths, connectors, and fittings are free of damage. Replace any components as necessary. This service can be performed by your local authorized ARB Stockist.

FITTING REQUIREMENTS

REQUIRED TOOLS FOR FITMENT OF PRODUCT:

METRIC SPANNER and SOCKET TOOL SET	Sikaflex© Black
PHILIPS and FLAT BLADE SCREWDRIVERS	DIA 19mm HOLESAW
POWER DRILL DIA 13mm CHUCK CAPACITY	DRILL BITS, DIA 7.0 (@100mm min), 10.0mm
STEEL RULE 300mm	SCRIBER

HAVE AVAILABLE THESE SAFETY ITEMS WHEN FITTING PRODUCT:

Protective eyewear		Hearing protection	
--------------------	---	--------------------	---

NOTE: 'WARNING' notes in the fitting procedure relate to OHS situations, where to avoid a potentially hazardous situation it is suggested that protective safety gear be worn or a safe work procedure be employed. If these notes and warnings are not heeded, injury may result.

FASTENER TORQUE SETTINGS:

SIZE	Torque Nm	Torque lbft
M6	9Nm	4lbft
M8	22Nm	16lbft
M10	44Nm	32lbft
M12	77Nm	57lbft

PARTS LISTING

APPLICATION.	PART NO.	QTY	DESCRIPTION
MOUNT BRACKETS TO VEHICLE 1500 MODEL ONLY (INC. BRACKET SET 3552030)	3756968R&L	1+1	BRACKET BAR MOUNT SET
	3757018R&L	1+1	BRACKET REINFORCING SET
	4581049	20	M12 WASHER FLAT
	4581050	10	M12 WASHER SPRING
	6151189	10	NUT M12x1.75
	6151255	10	BOLT M12 X 40
	3199893	2	PLATE CAGE NUT
	6151304	2	NUT CAGE M10
	6151232	2	BOLT SEMS M10 X 30mm
MOUNT BRACKETS TO VEHICLE 2500/3500 MODELS ONLY (INC. BRACKET SET 3552040)	3756969R&L	1+1	BRACKET BAR MOUNT SET
	6151299	2	BOLT M10 X 100
	6151321	2	NUT M10 FLANGED
	4581040	2	WASHER M10 X 3mm
WINCH	180302	8	CABLE TIE
TOW HOOK RELOCATION	6151365	2	EYEBOLT M24 2.5T SWL
	6151361	2	NUT M24 GR8 ZP
	3756765	2	BRACKET NUT RETAINING
	4581300	2	WASHER M24 EYEBOLT
	6151046	2	WASHER M6
	6151017	2	BOLT M6 X 16mm
	6151128	2	NUT FLANGE M6
CONTROL BOX FITTMENT	4581291	2	WASHER M10 BZ
	6151321	2	NUT FLANGED
	6151364	2	SCREW CAP M10X30 ZP
	3756775	1	BRACKET STD CONTROL BOX IN PAN
	3199790	1	TRIM PLATE FOR 16500LB CONTROL
NUMBER PLATE FITTMENT	6151017	4	BOLT M6 X 16mm
	6151128	4	NUT FLANGE M6
	6151046	4	WASHER M6
	3751313	1	BRACKET NO.PLATE
WINCH COVER FITTMENT	6151128	2	NUT FLANGE M6
	6151256	2	SCREW M6 S/STEEL BUTTON HEAD
	6151046	2	WASHER M6
	6191013	1	EXTRUSION WINCH COVER @ 1757
	6522048	1	PANEL WINCH COVER

BAR TO MOUNT ASSEMBLY	6151255	6	BOLT M12 X 40mm
	4581050	6	WASHER SPRING M12
	4581049	12	WASHER FLAT M12
	6151321	2	NUT M10 FLANGED
	6151232	2	BOLT SEMS M10 X 30mm
	6151189	6	NUT M12x1.75
INDICATOR ASSY	6821151R	1	INDICATOR ASSY RHS
	6821151L	1	INDICATOR ASSY LHS
	6151308	4	SCREW SELF TAPPING
	6821116	4	NUT NYLON PLUG
	6821152	2	LOOM
	180701	6	SCOTCH LOCKS
	180302	4	CABLE TIE
RETAINER FENDER LINER	3756948R	1	PLATE RETAINER FENDER LINER
	3756948L	1	PLATE RETAINER FENDER LINER
	6151300	4	NUT CAGED M6
	6151213	4	SCREW M6X20 BZ
	4581082	4	WASHER M6 BZ
FOG LAMPS	3756949	2	ADAPTER BRACKET
	6821189	2	GROMMET
	6151300	6	NUT CAGED M6
	6151017	6	BOLT M6 X 16
	6151046	6	WASHER M6
	4581036	6	WASHER SPRING M6
	3162457	1	LIGHT APERTURE MOLDING RH
	3162456	1	LIGHT APERTURE MOLDING LH

***** NOTE:**

- **FOR IPF OPTIONAL FOG LAMPS, ORDER SUPPLIMENTARY KIT# 9381FCK.**
- **IF REFITTING OE FOG LAMPS, ADAPTER BRACKETS ARE SUPPLIED STANDARD WITH THIS BULL BAR FITTING KIT TO MOUNT THESE LAMPS.**

REMOVAL OF BUMPER



1. If fog lights fitted in bumper, undo fog light loom connection (connection located on LHS of bumper)
2. Remove bumper by undoing 4 x M12 nuts on 'U' bolts through chassis and withdrawing bumper off chassis mount position, set aside. Retain bumper retaining 'U' bolts and nuts.

Note: For 2500 turbo diesel shown (and 3500 TD), undo and remove intercooler top mount bolts and rubber suspension blocks, this will allow the intercooler to tip back at the top and clear of the bumper U bolts allowing removal).



3. If OE fog lights fitted and are required for re-fitment into bull bar, remove each light and bracket assembly and then remove lights as shown by prising the lug each side from the case and undoing the adjuster screw.
4. Also, if OE fog lamps are to be reused, remove fog lamp loom fitted to bumper for re-use.



FITTING PROCEDURE GENERAL

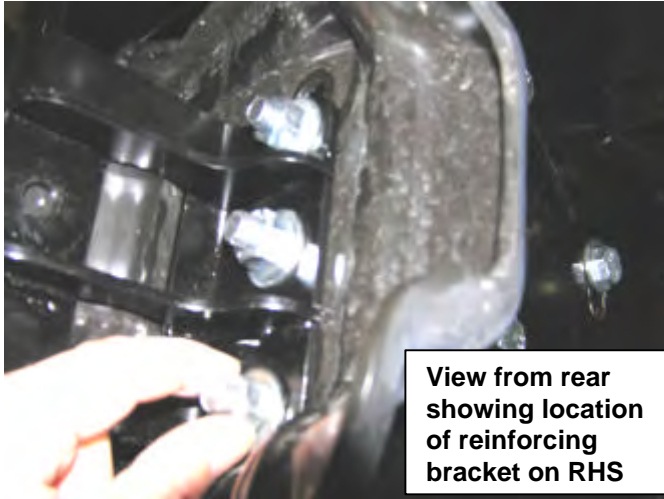

FOR 1500 MODEL VEHICLES FOLLOW STEPS 5 - 11, FOR 2500 AND 3500 VEHICLES STEPS 12 – 18.

5. Fit mount brackets to chassis end plates, fit reinforcing brackets behind flanges as shown. Fasten using M12 x 40 bolts, washer and nut sets, **but only nip up hand tight at this stage.**

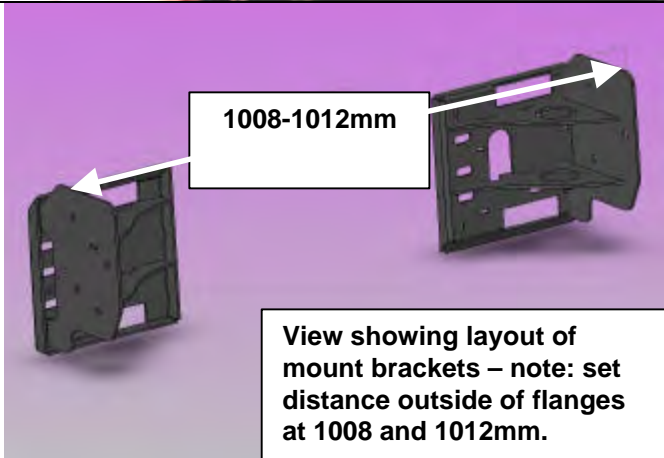

6. Align bracket set evenly on vehicle so that the outside measurement across vertical bracket plates is 1008-1012mm.
7. Do fasteners up tight, ensuring that reinforcing bracket is sitting snugly against chassis side face.
8. Recheck 1008-1012mm pitch, readjust if necessary.

NOTE: Distance between uprights in bull bar is 1013mm.



9. Drill 1 x M10 pinning hole in chassis using existing hole in reinforcing bracket as a guide.



Warning: Drilling operations can result in flying metal debris, safety glasses should be



10. Fit the M10 cage nut to nut plate as shown.

FITTING PROCEDURE GENERAL

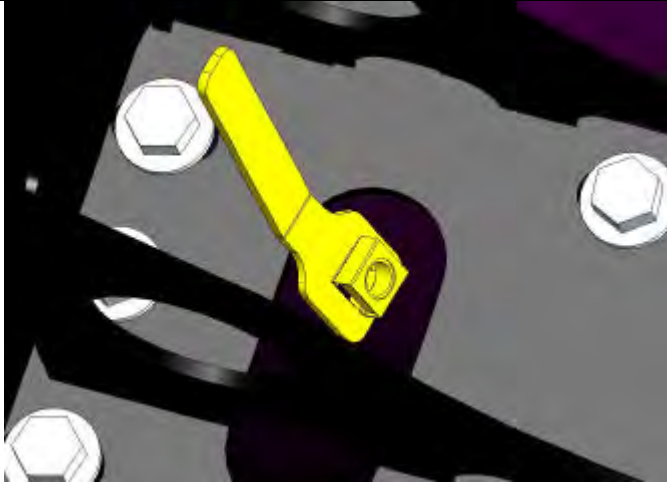

11. For pinning bolt from outboard of reinforcing bracket, fit cage nut plate assembly through into chassis end aperture as shown, then fasten in place through drilled pinning hole with M10 x 30 SEMS bolt and washer set. Do up tight. Repeat for other side of vehicle.

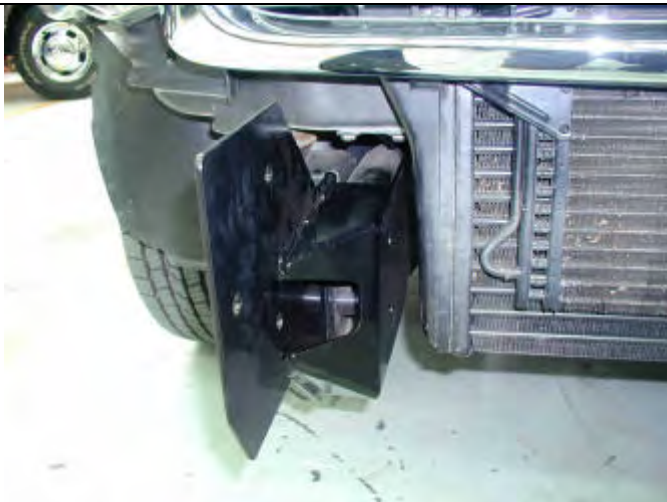

2500 AND 3500 ONLY STEPS 12 - 18

12. Fit chassis brackets as shown.



13. Insert original U bolts, entering from *inboard* face of chassis (you may have to tilt intercooler to gain sufficient clearance to allow U bolt to enter this side).
14. Set brackets so front edge is vertical then do bolts up tight.
15. Replace the intercooler suspension blocks and bolts if removed for U bolt removal.

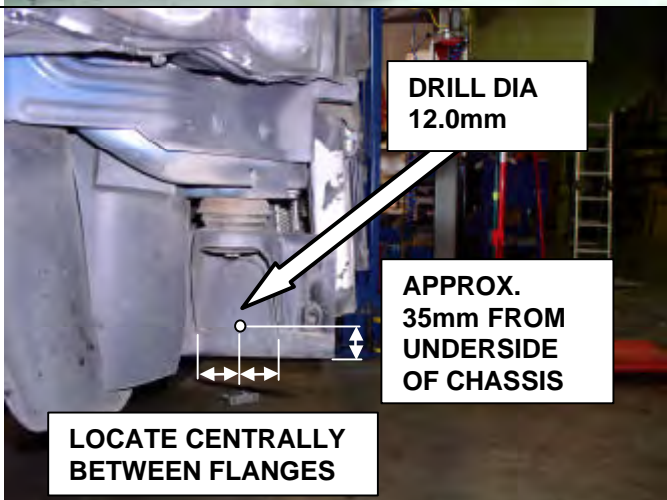

16. Mark the position for the pinning hole centrally between the body mount bracket flanges as shown on the outboard face of the chassis rails.
17. Drill through both sides of chassis and mount bracket flange Dia 10.0mm.
18. Fit M10 x 100 pinning bolt, M10 x 3MM washer and flange nut set and do up tight.



Warning: Drilling operations can result in flying metal debris, safety glasses should be worn.

FITTING PROCEDURE GENERAL



19. Remove lights from cartons and then remove screws and speed nuts from each light. These fasteners are not to be reused – new screws are supplied in the fitting kit



20. Insert nylon nuts into square holes in light brackets inside wing area



21. Fit lights using screws supplied in fitting kit, taking note of RH and LH light bodies, they are different and must be placed on the correct side of bull bar.



22. Fit large eyebolt nut into the plate on the inside of the bar.

FITTING PROCEDURE GENERAL



23. Screw in the eyebolt using the large washer. Eyebolt can be positioned to sit vertically by rotating the large nut to the correct position

NOTE: EYEBOLTS SHOULD BE REMOVED FOR SAFETY REASONS WHEN TRAVELLING ON PUBLIC ROADS.

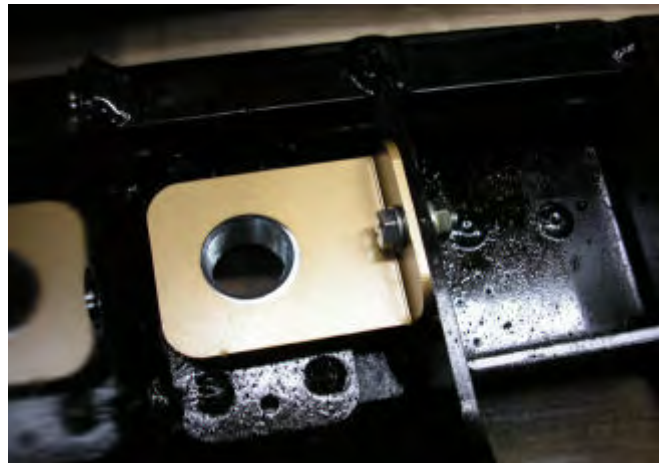

24. When the large nut is in its final position, secure with the nut retaining bracket using an M6 bolt, washer and flange nut.



25. Secure the number plate bracket using M6 bolts, flat washers and flange nuts. Attach the longer side to the bullbar and the shorter side to the number plate.



Note: As supplied from Warn, the winch handle on 1500 and 16500lb winches should be in the position as shown. This is correct orientation for this bar.

26. Remove cable retaining band and position cable loop so it will go through roller fairlead when it is placed in bull bar.

FITTING PROCEDURE WINCH

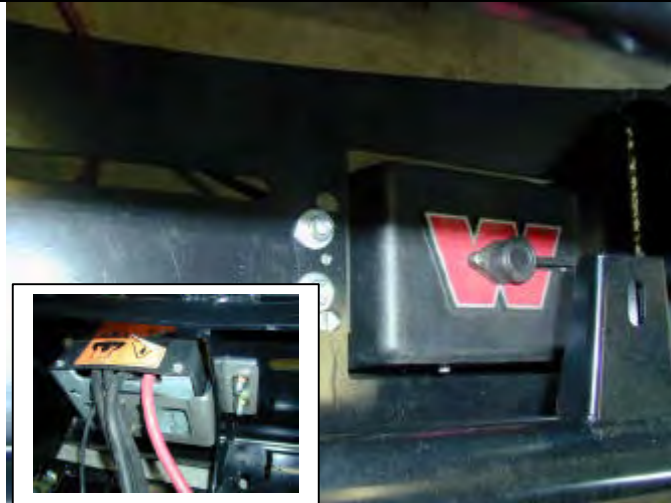

Fit control box to pan:

- For 9500-12000lb winches, use universal control box bracket supplied, attaching to rear of control box mount studs.
- Slide bracket flange under pan and align with mount slots.

27. Fasten in position with 2 x M10 cap screws, black washers and flange nuts



- For 15000lb winches, use Warn supplied control box bracket, attaching to rear of control box mount studs.
- Slide bracket flange under pan and align with mount slots.

28. Fasten in position with 2 x M10 cap screws, black washers and flange nuts.



- For 16500lb winches, apply Sikaflex (or similar product) to rear of control box trim plate from fitting kit (note orientation critical to suit final position with control box profile in pan opening).
- Position trim plate on top of pan centrally about control box opening and line up with mount slots.

29. Fasten in position with 2 x M10 cap screws and flange nuts from fitting kit.

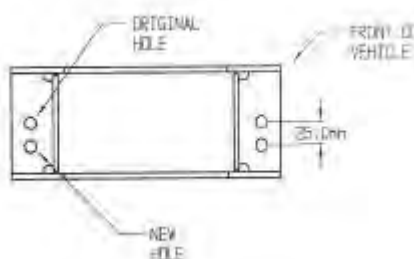

30. In some cases, the roller fair lead bracket must have a second set of holes drilled to line up with holes in winch bracket. If required, mark out as shown and using a 13.0 mm drill bit, drill two holes as shown in diagram.

FITTING PROCEDURE WINCH

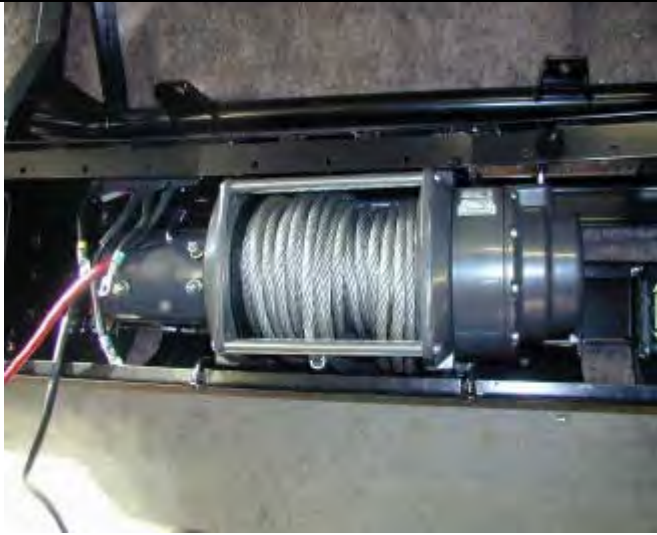

31. Viewed from front of vehicle the winch clutch (handle) must be positioned on the LH side (same side as smaller square access hole in pan). Cable must spool from the bottom of winch. Draw off enough cable so cable crimp can be pulled through roller fairlead.

32. Bolt winch in position with the roller fair lead in place.

Hint: To increase access to mount bolts in front of roller fairlead, remove circlips from bottom of each vertical roller shaft, push shaft up so roller can be dislodged sideways. Do up bolts in fairlead and winch, then refit circlip.

33. Connect the winch control box cables to the winch motor. Refer to the Warn handbook for additional information. Connect the long winch + & - cables to the vehicle after the bar is installed. **Refer to the Warn winch manual for vehicle wiring instructions.**



34. **Fitting number plate – with winch**

Bolt number plate to the bracket with the M6 X 16mm bolts and M6 flange nuts through the lower holes of the number plate.

If not fitting winch.

Bolt the number plate through the top holes using M6 X 16mm bolts and M6 flange nuts.



View from above, rear of bull bar

35. **If not fitting winch cont.**

36. Wrap rubber extrusion around winch cover.

37. Place washers over the winch cover fixing holes located on the top middle face of the winch bumper.

38. Place the winch cover on top of the winch bumper inline with the mount holes.

39. Bolt together using the M6 button head stainless steel screws and M6 nuts.

FITTING PROCEDURE BAR ON VEHICLE



40. Using two people, three if winch fitted, position the bar assembly on the vehicle mounts.

Caution: *This product is heavy, especially if a winch is fitted. Do not attempt to lift it and fit it by yourself. Have some assistants help you or use a mechanical aid such as this hydraulic lift table as shown.*



40. Bolt the bar to the mounts using M12 bolts, large flat washers and spring washers. Bolt the bar to the mounts using M12 bolts, large flat washers and spring washers. Align the bar to the profile of the guards, grille and light profile and tighten all bolts.

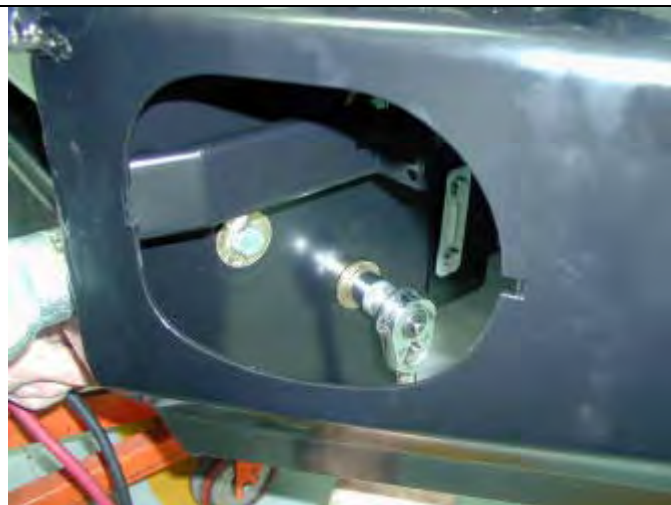

41. When bar is aligned, tighten bolts.



42. Using the M10 pilot holes in mount brackets, drill pinning hole through uprights on bull bar. Fit M10 screw, washer set and flange nut and do up tight.



Warning: Drilling operations can result in flying metal debris, safety glasses should be worn.

FITTING PROCEDURE BAR ON VEHICLE



If fitting optional accessory fog lamps kit **9381FCK** follow fitting instructions supplied with kit. If fitting OE fog lights follow steps 43 – 48.

43. Fit M6 cage nuts and grommet to adaptor bracket as shown.



44. Fit light to adaptor bracket by locating mount lugs in light body into holes in adaptor bracket flanges.
45. Screw adjuster into grommet so that light is approximately parallel to bracket.



46. Fit adapter bracket and fog lamp assembly into brackets in bull bar wings, as shown.
47. Bolt in place with M6 x 16 bolt and washer sets into cage nuts.
48. Route OE fog lamp loom and connect to lamps.



Fitting plastic fog lamp aperture moldings.

49. If fog lamps are fitted, cut centre panel out of light aperture moldings using a hack saw blade.
50. If fog lamps are not fitted leave centre panel in place.

FITTING PROCEDURE BAR ON VEHICLE



51. Note that the aperture moldings are handed (RH or LH), select correct hand for each wing aperture. Apply Sikaflex to recess in aperture molding flange then fit to aperture in wing. Use adhesive tape to secure plastic mold while Sikaflex cures.



52. Use adhesive tape to secure plastic mold while Sikaflex cures.



53. Wire up indicators and running lamps. Wire loom extensions are supplied in fitting kit.



54. If winch fitted, fit off winch hook.

FITTING PROCEDURE BAR ON VEHICLE

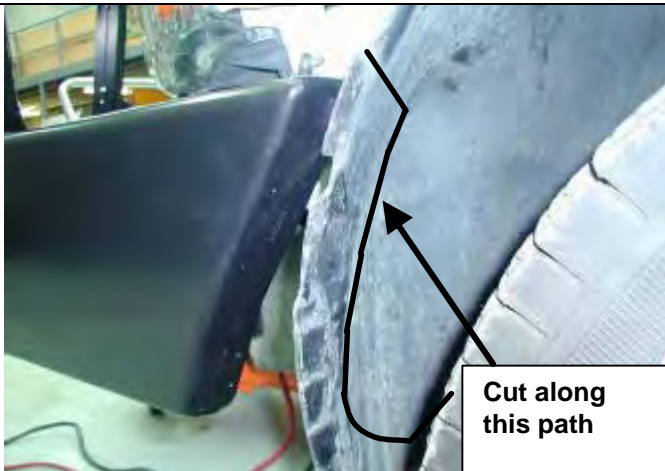

55. Trim fender liner with air hacksaw or similar tool along line as shown. Cut away the outboard flap, which normally fits in the end of the bumper wing. This is so the liner can be held back easily by the retaining bracket at step 56.



56. Fit liner retainer bracket with black M6 bolt and washer sets into M6 cage nuts in wing returns each side as shown.

FITTED PRODUCT ON 1500 MODEL

