



SIGNATURE OF QUALITY

AUTOMOTIVE PRODUCTS, INC.

# INSTALLATION INSTRUCTIONS

HDX RUNNING BOARDS

APPLICATION: TOYOTA TUNDRA 2007-14 CREW MAX

PART # 57-53255

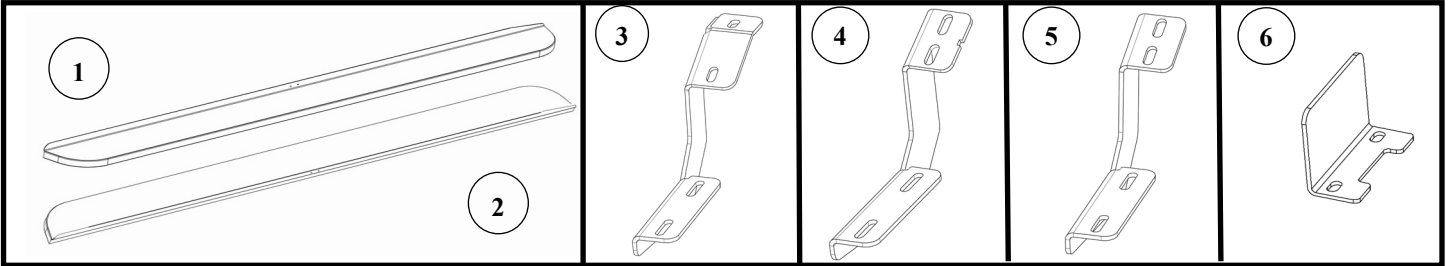

ITEM	QUANTITY	DESCRIPTION	TOOLS NEEDED
1	1	RUNNING BOARD PASSENGER	13MM SOCKET
2	1	RUNNING BOARD DRIVER	13MM WRENCH
3	2	FRONT BRACKET	RATCHET
4	2	MID BRACKET	RATCHET EXTENSION
5	4	REAR BRACKET	TORQUE WRENCH
6	2	BOOT SCRAPER	5/16" DRILL BIT
7	32	M8 HEX HEAD BOLT	TRANSFER PUNCH
8	32	M8 24MM FLAT WASHER	SILICONE
9	32	M8 LOCK WASHER	
10	16	M8 U-NUT	
11	4	M9.5 EXTERNAL TOOTH LOCK WASHER	
12	4	M9.5 HEX HEAD SELF TAP SCREW	

**ANTI-SEIZE LUBRICANT MUST BE USED ON ALL STAINLESS STEEL FASTENERS TO PREVENT THREAD DAMAGE AND GALLING .**

1. Remove contents from box, verify if all parts listed are present and free from damage. Carefully read and understand all instructions before attempting installation.
2. Identify driver and passenger side running boards and install M8 u-nut clips (Item 10) to the underside of the boards. **Figure 1.**
3. Locate four mount existing threaded locations at each side, and remove existing bolts. **Figures 3 & 5.** Note: Bolts will not be reinstalled.
4. Starting at the drivers side install (1x) front mounting bracket (item 3), and attach it to the existing threaded holes, using (2) M8 hex head bolts (item 7), (2x) M8 lock washers (item 9), and (2x) M8 large flat washers (item 8). *Do not fully tighten at this time, Figure 3 & 4.*
5. Follow steps 3 and 4 to install (1x) mid bracket (Item 4) and (2x) rear brackets (Item 5) **Figures 5 & 6.**
6. Repeat steps 3-5 for the mid and rear mounting brackets. **Figures 5 to 6.**
7. Take the drivers side running board and place it onto the mounting bracket cradles; align the running board with the mounting holes in the brackets and attach using (8x) M8 hex head bolts (item 7), (8x) M8 lock washers (item 9), and (8x) M8 large flat washers (item 8) **Figure 2.** *Do not fully tighten at this time.*
8. Align and adjust the running board as needed then fully tighten all hardware at this time. Torque all M8 hardware to 20 ft lbs.
9. Repeat steps 3-8 for the passenger side.



Westin Automotive Products, Inc.  
320 Covina Blvd  
San Dimas, Ca. 91773

SIGNATURE OF QUALITY

Thank You for choosing Westin products  
For Additional installation assistance please call  
Customer service (800) 793-7846  
www.westinautomotive.com

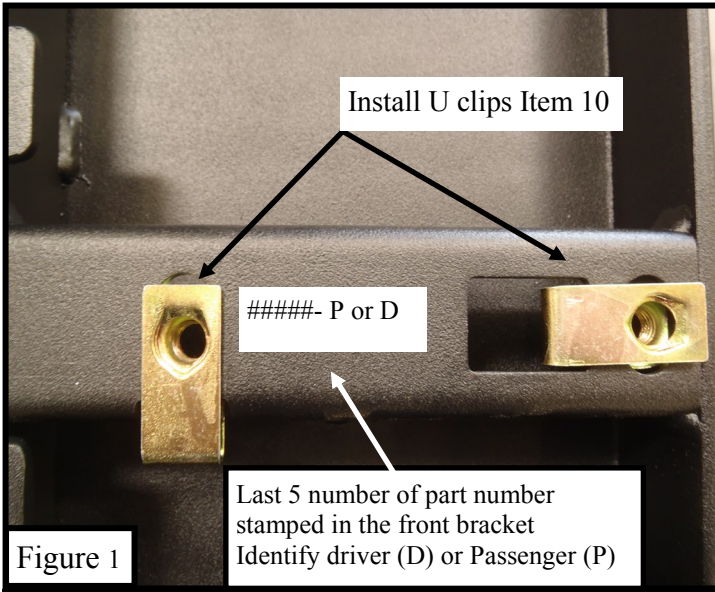

Figure 1

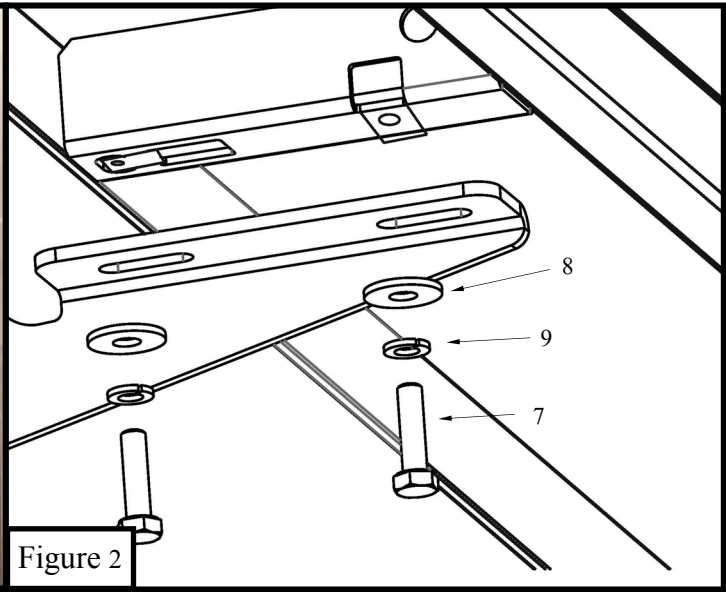

Figure 2

FRONT MOUNTING LOCATION

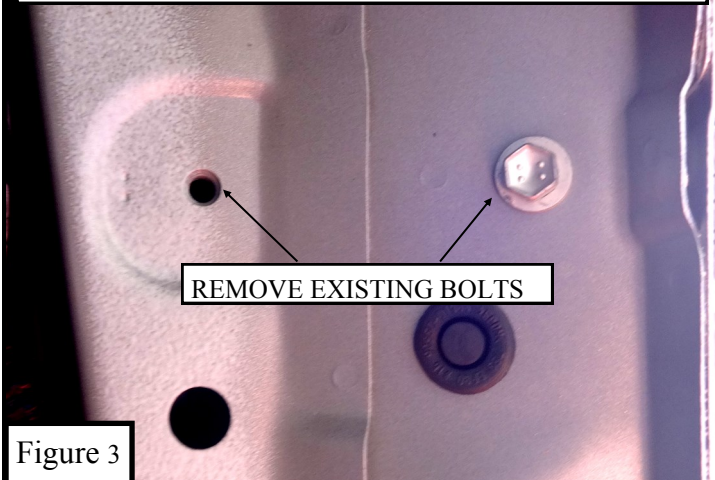

Figure 3

FRONT BRACKET

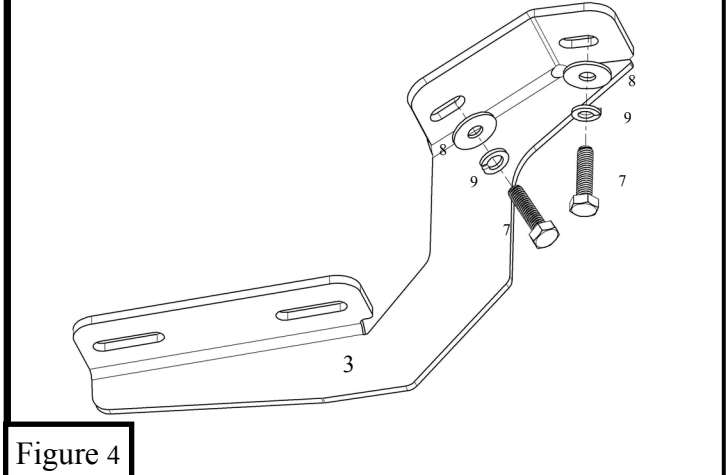

Figure 4

MID AND REAR MOUNTING LOCATIONS PER SIDE  
1X MID AND 2X REAR

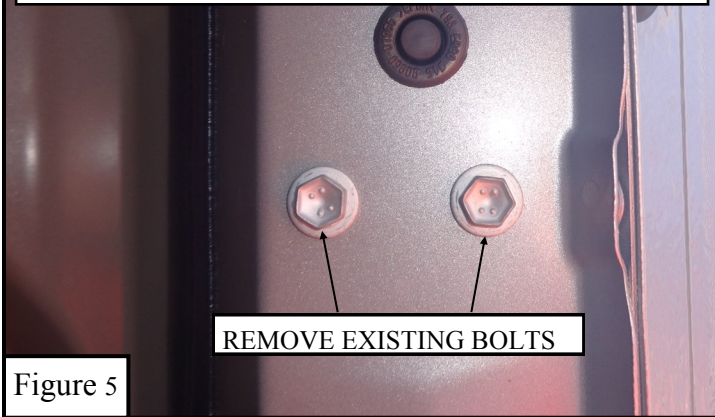

Figure 5

MID AND REAR MOUNT BRACKETS PER SIDE:  
SHOWN - MID BRACKET 1X  
NOT SHOWN - REAR BRACKET 2X

NOTE:  
MID AND REAR BRACKETS LOOK SIMILAR  
MID BRACKET HAS A NOTCH

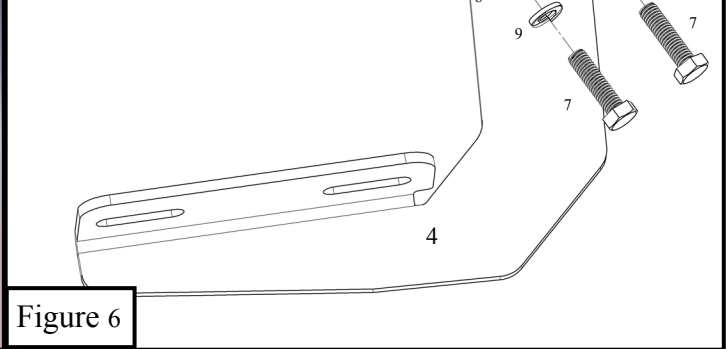

Figure 6



Westin Automotive Products, Inc.  
320 Covina Blvd  
San Dimas, Ca. 91773

Thank You for choosing Westin products  
For Additional installation assistance please call  
Customer service (800) 793-7846  
www.westinautomotive.com

Figure. 7

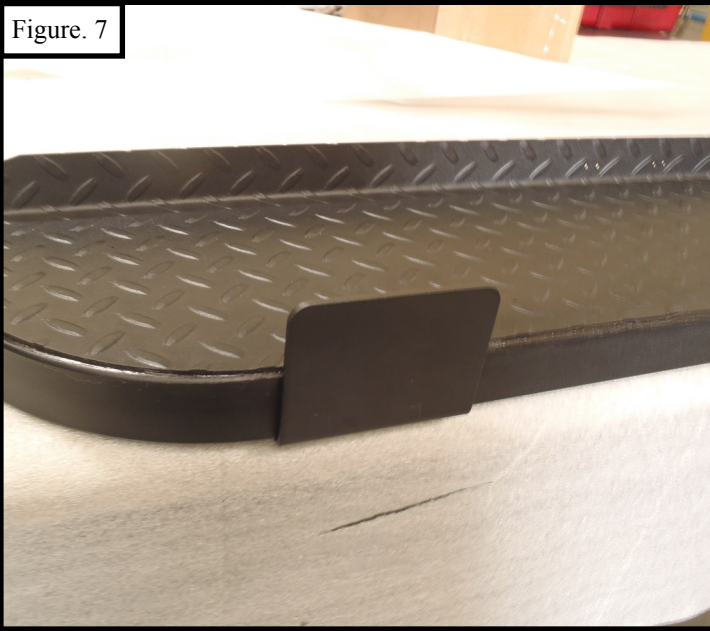
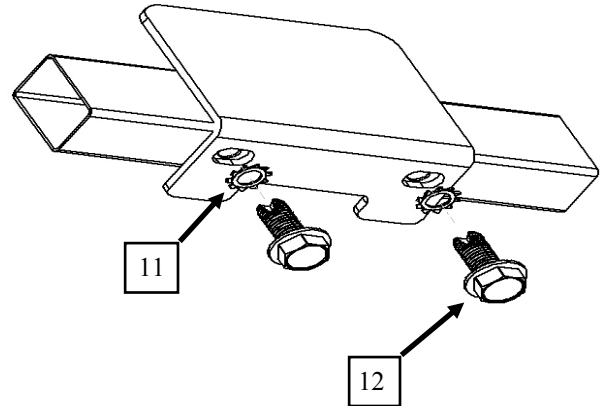

Figure. 8



**Boot scraper (OPTIONAL)** can be installed anywhere on the underside front edge of the running board. Place the boot scraper (item 5) on the underside of the running board rail. Then mark the position that it will be installed using a transfer punch. Remove the boot scraper; then using a 5/16" drill bit align it with the previously made marks and drill through the bottom of the rail on the running board. Thread in (2x) 9.5mm hex head self tapping screws. Remove the screws and add some silicone sealant in the holes to prevent rust. Attach the boot scraper (item 6) using (2x) 9.5mm Hex Flange Head Self Threading Screw (item 12) and (2x) 9.5mm external toothed lock washers (item 11). (**Figure 8**) Torque all M9.5 hardware to 18 ft. lbs.

Installation complete



Westin Automotive Products, Inc.  
320 Covina Blvd  
San Dimas, Ca. 91773

Thank You for choosing Westin products  
For Additional installation assistance please call  
Customer service (800) 793-7846  
[www.westinautomotive.com](http://www.westinautomotive.com)