



AUTOMOTIVE PRODUCTS,

# INSTALLATION INSTRUCTIONS

CLASS III RECIEVER HITCH

APPLICATION:

2015-2016 Chevrolet Colorado

2015-2016 GMC Canyon

PART NUMBER:

65-1535

ITEM	QUANTITY	DESCRIPTION	TOOLS NEEDED
1	1	HITCH ASSEMBLY	13MM SOCKET
			21MM SOCKET
			(2) JACK STANDS
			9" SOCKET EXT.
			RATCHET
			TORQUE WRENCH

**ANTI-SEIZE LUBRICANT MUST BE USED ON ALL STAINLESS STEEL FASTENERS TO PREVENT THREAD DAMAGE AND GALLING**

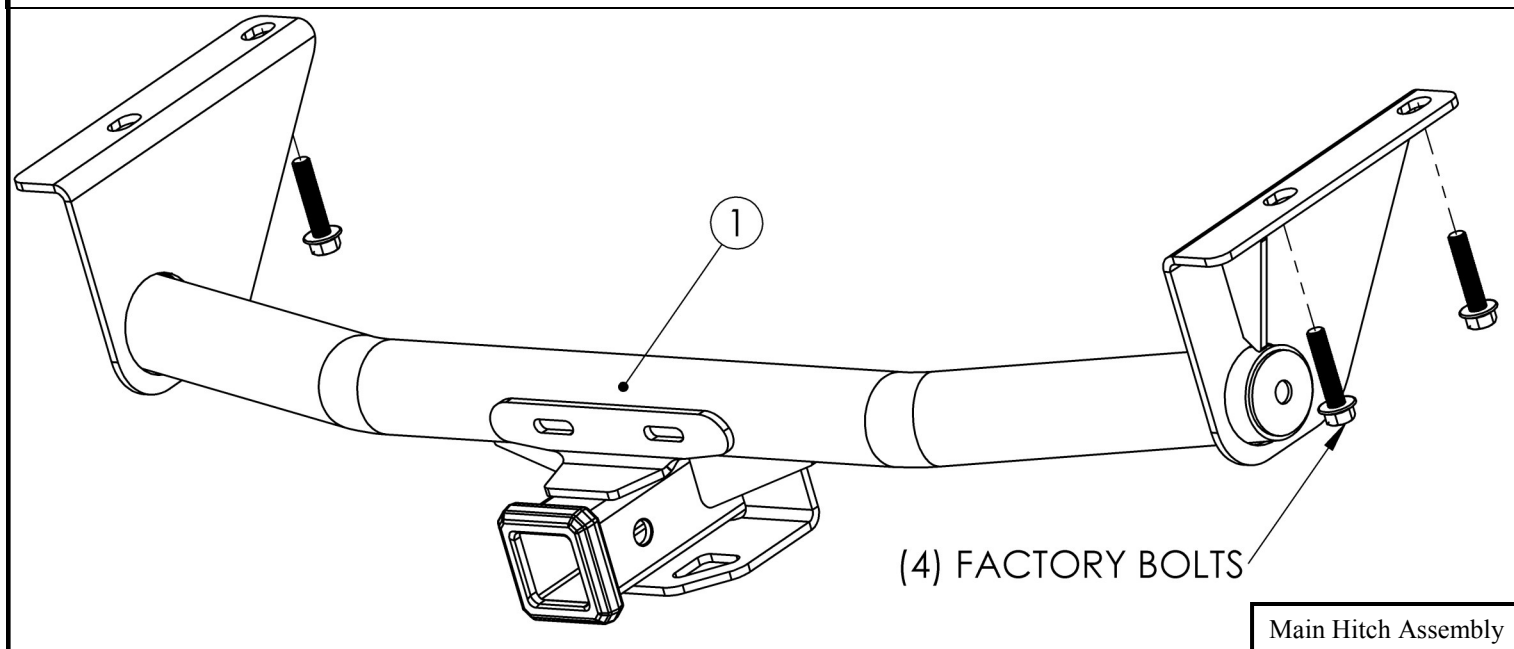

## PROCEDURE

1. Remove contents from box, verify if all parts listed are present and free from damage. Carefully read and understand all instructions before attempting installation.  
**Failure to identify damage before installation could lead to a rejection of any claim.**
2. Lower the spare tire using the vehicle service tools located in the cab of the truck. Remove the center bracket by removing (4) factory bolts with a 13mm socket. Raise spare tire back into position. **See Fig. 1 & 2.**
3. Support the bumper with the two jack stands. Remove (8) factory bolts securing the factory cross member/hitch to the frame rail with a 21mm socket. Set the (8) factory bolts aside for reuse during the hitch assembly installation. (Note: The bumper shares the same mounting points and should be supported from underneath with the two jacks.) **See Fig. 3.**



Westin Automotive Products, Inc.  
320 W. Covina Blvd  
San Dimas, Ca. 91773

Thank you for choosing Westin products  
for additional installation assistance please call  
Customer Service (800) 793-7846

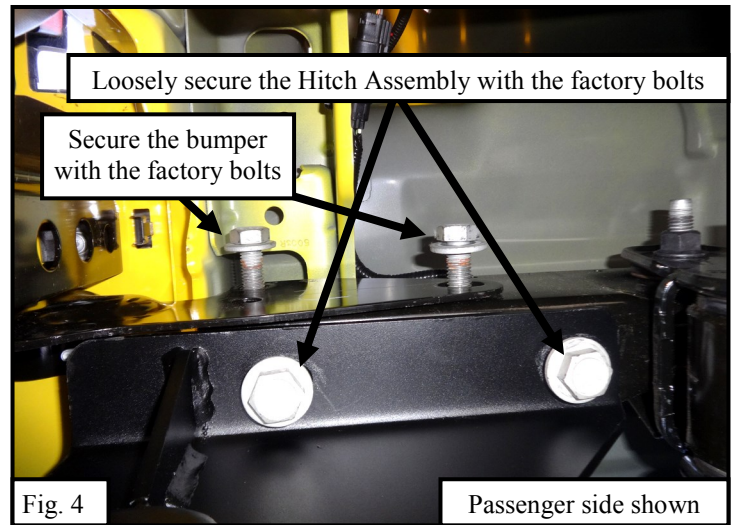
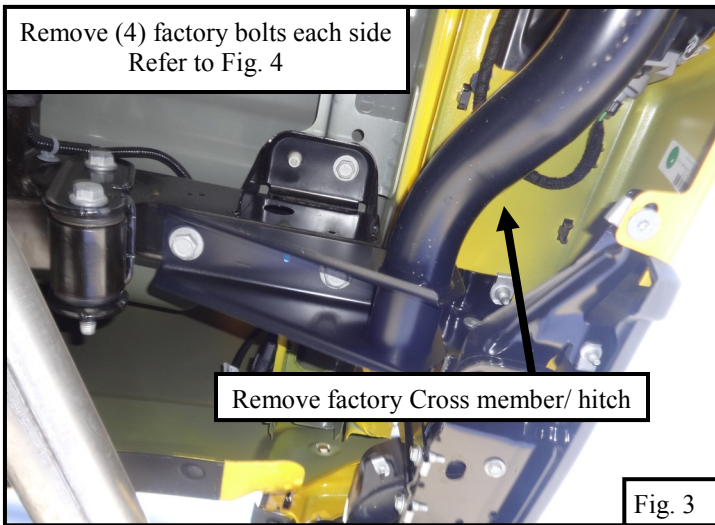
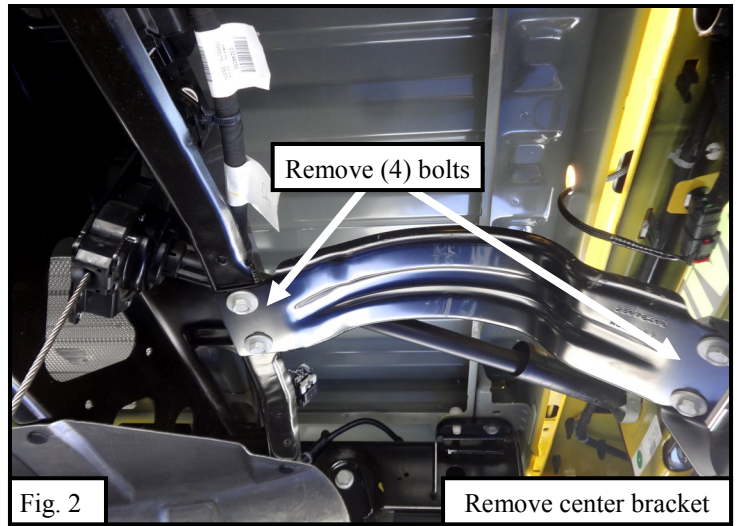

4. Carefully remove the factory cross member/hitch from vehicle making sure that all wirings clears. **See Fig. 3.**
5. Locate the Hitch Assembly (Item 1) and with assistance align the hitch with the 4 factory threaded holes. Loosely secure the hitch using the (4) factory bolts. Secure the bumper with the factory bolts. **See Fig. 4.**
6. Align and adjust the Hitch Assembly as needed, then fully tighten all hardware at this time. Torque all M14 fasteners to 126 ft-lbs.



#### CARE INSTRUCTIONS

- REGULAR WAXING IS RECOMMENDED. DO NOT USE ANY TYPE OF POLISH OR WAX THAT MAY CONTAIN ABRASIVES.
- STAINLESS STEEL PRODUCTS CAN BE CLEANED WITH MILD SOAP AND WATER. STAINLESS STEEL POLISH SHOULD BE USED TO POLISH SMALL SCRATCHES.
- GLOSS BLACK FINISHES SHOULD BE CLEANED WITH MILD SOAP AND WATER.



Westin Automotive Products, Inc.  
320 W. Covina Blvd  
San Dimas, Ca. 91773

Thank you for choosing Westin products  
for additional installation assistance please call  
Customer Service (800) 793-7846



SIGNATURE OF QUALITY

AUTOMOTIVE PRODUCTS, INC.

## WARNINGS & NOTICES FOR THE INSTALLATION OF WESTIN TOWING PRODUCTS - CLASS III RECEIVER HITCH

### NOTICE

Westin Receiver Hitches are designed to accommodate a 2"- square receiver draw bar rated for class III/IV towing. Closely follow all Westin Installation Instructions for the proper installation of product. Improper installation can result in death, serious injury, and/or product and vehicle damage. In the operation of these products, it is imperative to observe precautions for your personal safety and the safety of others.



### WARNING



Failure to follow these instructions could lead to death, personal injury, and / or property damage.

#### FASTENERS:

All Westin supplied fasteners must be utilized and installed in accordance with the installation instructions and apply torque to the specifications as defined. **DOUBLE CHECK ALL FASTENERS BEFORE INITIAL USE, AND PERIODICALLY IN THE FUTURE TO ENSURE PROPER FUNCTION AND SAFETY.**

#### DRILLING:

Most Westin products do not require drilling for installation. If drilling is defined as required, use caution when drilling a vehicle. **FAILURE TO REVIEW AN AREA TO BE DRILLED MAY RESULT IN PERSONAL INJURY AND/OR INJURY TO OTHERS AS WELL AS VEHICLE DAMAGE.**

#### EYE PROTECTION:

**ALWAYS WEAR SAFETY GLASSES OR GOGGLES DURING THE INSTALLATION PROCESS TO AVOID PERSONAL INJURY.**

#### MAXIMUM TOWING/CARRYING CAPACITY:

The Westin Receiver Hitches will have a visible tow rating label affixed directly on the product. User should never exceed the vehicle manufacturers maximum tow and weight rating regardless of the capacity of the hitch. **FAILURE TO FOLLOW THESE GUIDELINES WILL VOID THE WESTIN WARRANTY AND MAY RESULT IN PERSONAL INJURY AND/OR INJURY TO OTHERS AS WELL AS VEHICLE DAMAGE.**



Westin Automotive Products, Inc.  
320 W. Covina Blvd  
San Dimas, Ca. 91773