



INSTALLATION INSTRUCTIONS

HDX DROP STEP WTW

APPLICATION:

2016-2017 Toyota Tacoma - Double Cab 6 Ft Bed

PART NUMBER:

56-534185, 56-5341852

CONTENT			
ITEM	QUANTITY	DESCRIPTION	TOOLS NEEDED
1	2	STEP BAR ASSEMBLY	13MM SOCKET
2	1	FRONT DRIVER SIDE MOUNTING BRACKET	13MM WRENCH
3	4	MOUNTING BRACKET B	RATCHET
4	12	LONG M8 HEX HEAD CAP SCREW (YELLOW ZINC)	TORQUE WRENCH
5	28	M8 SPLIT LOCK WASHER (YELLOW ZINC)	RATCHET EXT.
6	28	M8 FLAT WASHER (YELLOW ZINC)	18MM SOCKET
7	16	SHORT M8 HEX HEAD CAP SCREW (YELLOW ZINC)	19MM SOCKET
8	1	FRONT PASSENGER SIDE MOUNTING BRACKET	18MM WRENCH
9	2	M12 LONG HEX HEAD CAP SCREW (YELLOW ZINC)	19MM WRENCH
10	2	M12 SHORT HEX HEAD CAP SCREW (YELLOW ZINC)	
11	4	M12 SPLIT LOCK WASHER (YELLOW ZINC)	
12	4	M12 FLAT WASHER (YELLOW ZINC)	
13	2	M12 HEX NUT (YELLOW ZINC)	
14, 15	2	ISOLATOR BRACKET, DRIVER (14) AND PASSENGER (15)	
16	2	TOP ISOLATOR MOUNT BRACKET	
17	2	ISOLATOR KIT	
18	2	M12 NUT PLATE (YELLOW ZINC)	

ANTI-SEIZE LUBRICANT MUST BE USED ON ALL STAINLESS STEEL FASTENERS TO PREVENT THREAD DAMAGE AND GALLING

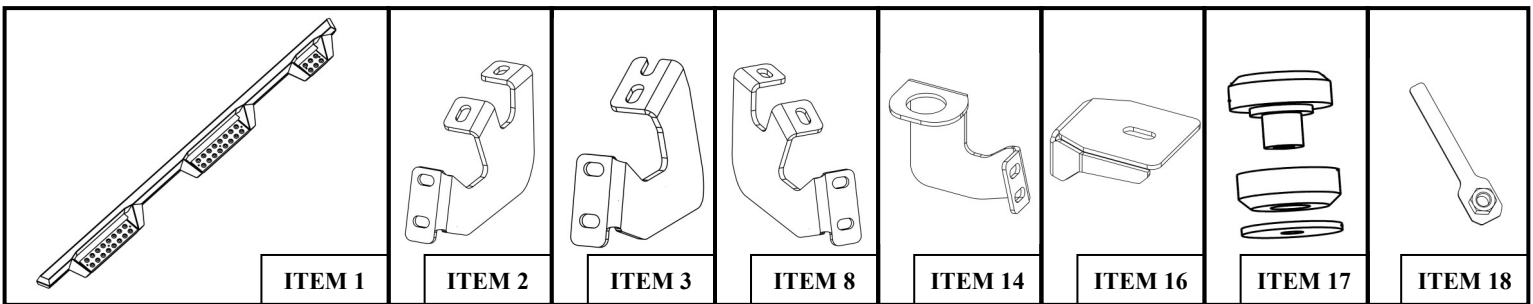

PROCEDURE

1. Remove contents from box, verify if all parts listed are present and free from damage.

Carefully read and understand all instructions before attempting installation.

Failure to identify damage before installation could lead to a rejection of any claim.



Westin Automotive Products, Inc.
320 W. Covina Blvd
San Dimas, Ca. 91773

Thank You for choosing Westin products
For Additional installation assistance please call
Customer service (800) 793-7846

2. Start installation on either side of the vehicle. Locate mounting locations with factory threaded holes with caps covering them. Remove factory caps from threaded holes, they will not be used again. Locate (1) Front Mounting Bracket and loosely install it to the front mounting location on the rocker panel using (2) Long M8 hex head cap screw, (2) M8 split lock washer, and (2) M8 flat washer (Items 4-6). Locate the Mounting Bracket B (Item 3) and loosely secure in the correct mounting locations on the rocker panel. Loosely install using the provided M8 hardware (Items 5-7). See **Figure. 1 and 2.**
3. Repeat Step 2 for the other vehicle side.

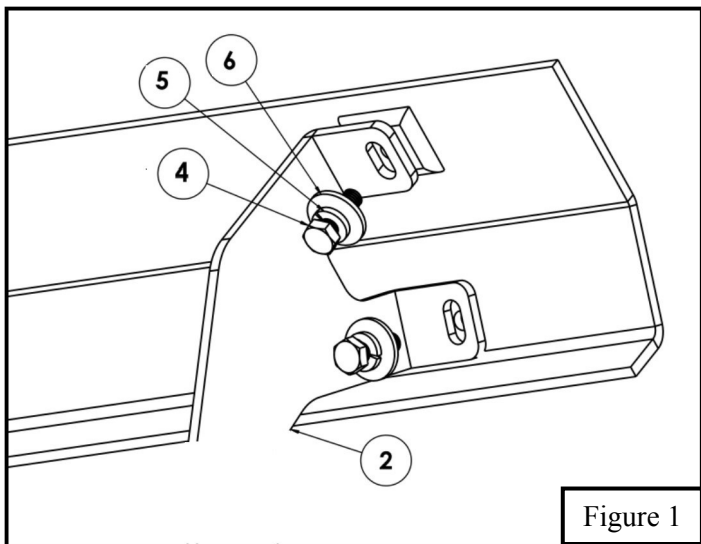

Figure 1

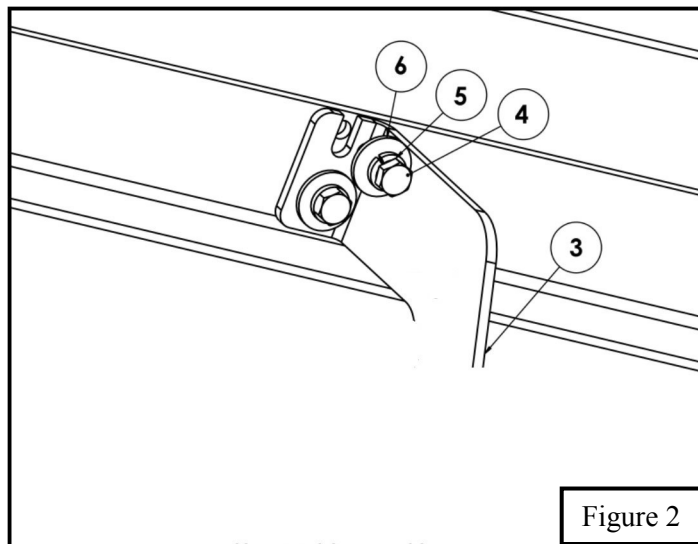

Figure 2

4. On driver side of the truck underneath the bed, locate a part of the frame that protrudes outward and has a large slot on its face. This is where you slide the M12 Nut Plate (item 18) and loosely install the Top Isolator Bracket (Item 16) with the supplied M12 hardware. See **Figure 3**
5. Locate (1) isolator kit (Item 17) and (1) isolator bracket (14/15) and loosely secure each other with the previously installed top isolator bracket. See **Figure 4.** (**Note:** See bracket orientation pg.3)

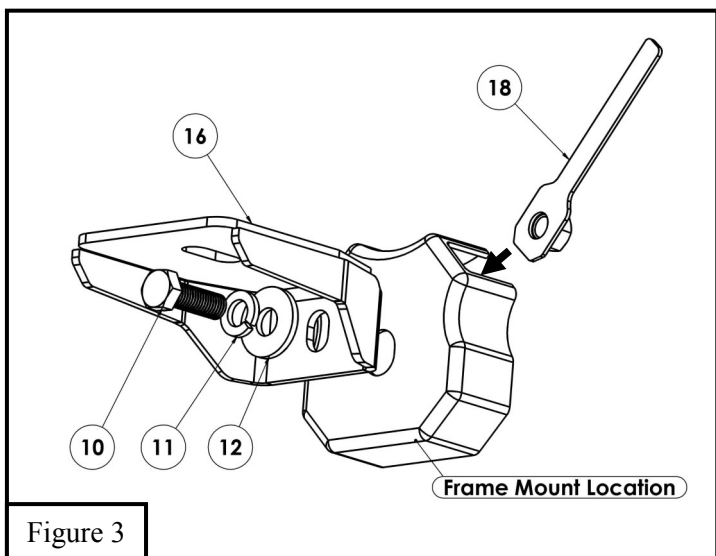

Figure 3

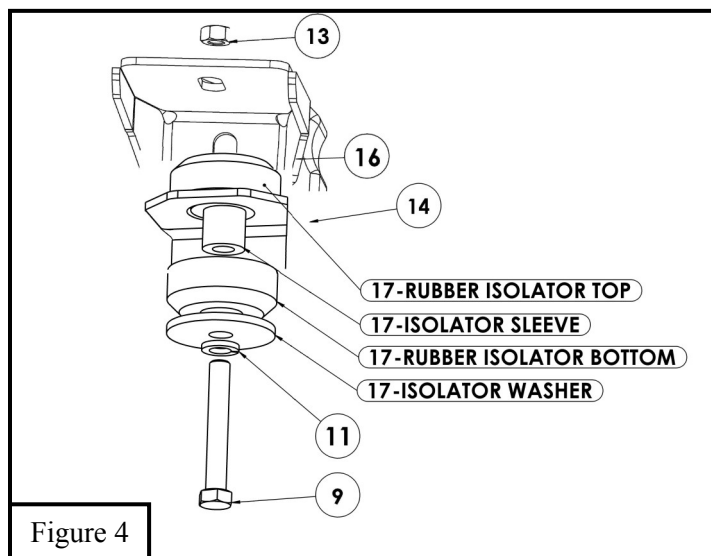

Figure 4



Westin Automotive Products, Inc.
320 W. Covina Blvd
San Dimas, Ca. 91773

Thank You for choosing Westin products
For Additional installation assistance please call
Customer service (800) 793-7846

6. For Step Board installation tilt board at angle to mount to brackets. See **Figure 5**.
7. For Step Board installation to the previously installed mounting brackets use the supplied Short M8 bolts and M8 hardware. See **Figure 6**.
8. Align step board and brackets to desired positioning then torque and tighten all: M8 hardware to 20 ft-lbs and M12 to 52-60 ft-lbs.

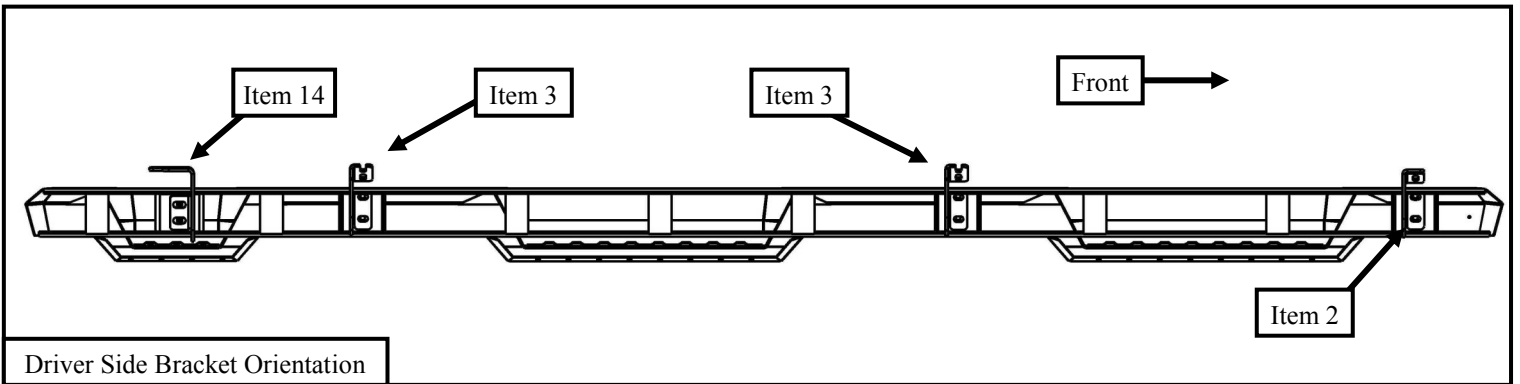
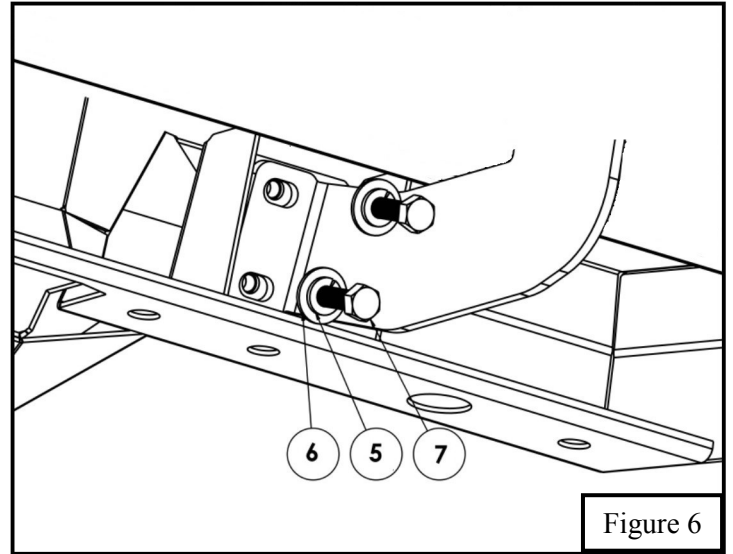
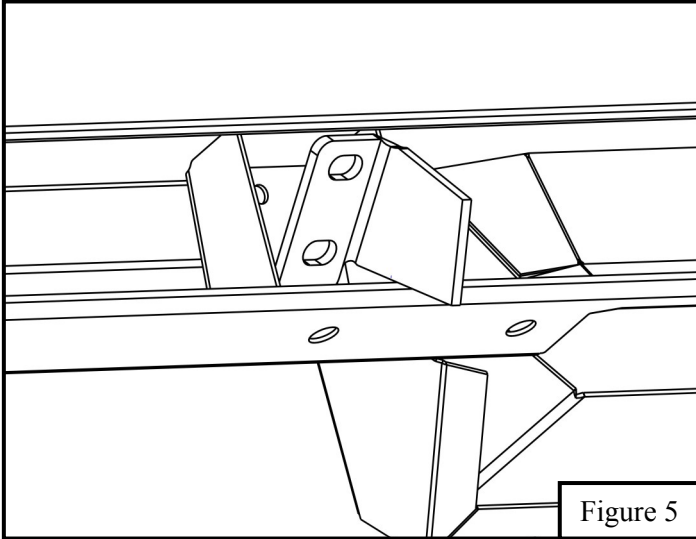

Westin Automotive Products, Inc.
320 W. Covina Blvd
San Dimas, Ca. 91773

Thank You for choosing Westin products
For Additional installation assistance please call
Customer service (800) 793-7846

INSTALLATION COMPLETE



Care Instructions

- REGULAR WAXING IS RECOMMENDED. DO NOT USE ANY TYPE OF POLISH OR WAX THAT MAY CONTAIN ABRASIVES.
- STAINLESS STEEL PRODUCTS CAN BE CLEANED WITH MILD SOAP AND WATER. STAINLESS STEEL POLISH SHOULD BE USED TO POLISH SMALL SCRATCHES.
- GLOSS BLACK FINISHES SHOULD BE CLEANED WITH MILD SOAP AND WATER.



Westin Automotive Products, Inc.
320 W. Covina Blvd
San Dimas, Ca. 91773

Thank You for choosing Westin products
For Additional installation assistance please call
Customer service (800) 793-7846
www.westinautomotive.com

Westin

SIGNATURE OF QUALITY

AUTOMOTIVE PRODUCTS, INC.



WARNING



Failure to follow these instructions could lead to death, personal injury, and / or property damage.

FASTENERS:

All Westin supplied fasteners must be utilized and installed in accordance with the installation instructions and apply torque to the specifications as defined. **DOUBLE CHECK ALL FASTENERS BEFORE INITIAL USE, AND PERIODICALLY IN THE FUTURE TO ENSURE PROPER FUNCTION AND SAFETY.**

DRILLING:

Most Westin products do not require drilling for installation. If drilling is defined as required, use caution when drilling a vehicle. **FAILURE TO REVIEW AN AREA TO BE DRILLED MAY RESULT IN PERSONAL INJURY AND/OR INJURY TO OTHERS AS WELL AS VEHICLE DAMAGE.**

EYE PROTECTION:

ALWAYS WEAR SAFETY GLASSES OR GOGGLES DURING THE INSTALLATION PROCESS TO AVOID PERSONAL INJURY.

MAXIMUM TOWING/CARRYING CAPACITY:

The Westin Receiver Hitches will have a visible tow rating label affixed directly on the product. User should never exceed the vehicle manufacturers maximum tow and weight rating regardless of the capacity of the hitch. **FAILURE TO FOLLOW THESE GUIDELINES WILL VOID THE WESTIN WARRANTY AND MAY RESULT IN PERSONAL INJURY AND/OR INJURY TO OTHERS AS WELL AS VEHICLE DAMAGE.**

Westin
SIGNATURE OF QUALITY

Westin Automotive Products, Inc.
320 W. Covina Blvd
San Dimas, Ca. 91773