



# INSTALLATION INSTRUCTIONS

AUTOMOTIVE PRODUCTS,

**APPLICATION:**  
**WJ2 Bull Bar Bumper LED Mounting Brackets**  
**PART NUMBER: 59-88015**

| ITEM | QUANTITY | DESCRIPTION         | TOOLS NEEDED  |
|------|----------|---------------------|---------------|
| 1    | 1        | MOUNTING BRACKET    | 16MM SOCKET   |
| 2    | 1        | MOUNTING BRACKET    | 16MM WRENCH   |
| 3    | 2        | M8 BUTTON HEAD BOLT | SOCKET EXT.   |
| 4    | 2        | M8 WASHER           | RATCHET       |
|      |          |                     | TORQUE WRENCH |
|      |          |                     | ALLEN WRENCH  |

**ANTI-SEIZE LUBRICANT MUST BE USED ON ALL STAINLESS STEEL FASTENERS TO PREVENT THREAD DAMAGE AND GALLING**

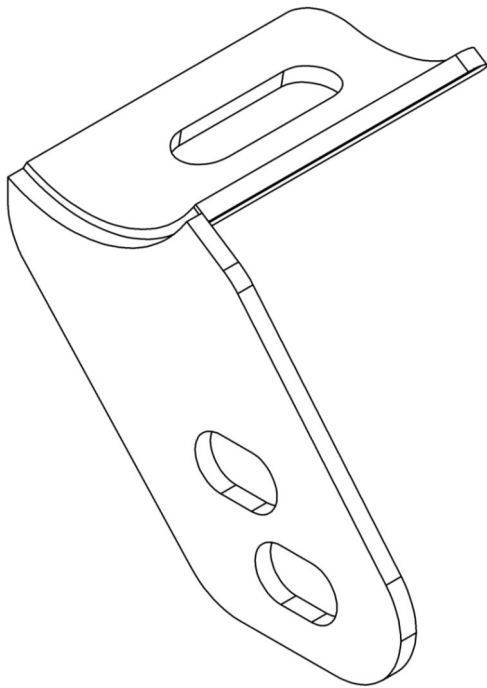

ITEM 1

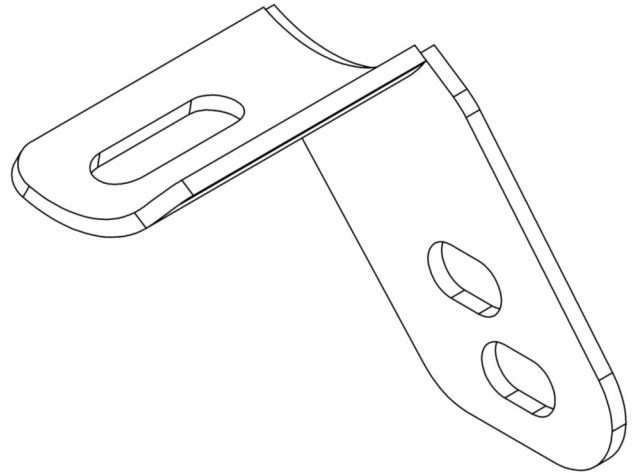

ITEM 2

### CARE INSTRUCTIONS

- REGULAR WAXING IS RECOMMENDED. DO NOT USE ANY TYPE OF POLISH OR WAX THAT MAY CONTAIN ABRASIVES.
- STAINLESS STEEL PRODUCTS CAN BE CLEANED WITH MILD SOAP AND WATER. STAINLESS STEEL POLISH SHOULD BE USED TO POLISH SMALL SCRATCHES.
- GLOSS BLACK FINISHES SHOULD BE CLEANED WITH MILD SOAP AND WATER.



Westin Automotive Products, Inc.  
320 W. Covina Blvd  
San Dimas, Ca. 91773

Thank you for choosing Westin products  
for additional installation assistance please call  
Customer Service (800) 793-7846

# FULL WIDTH BUMPER BRACKET INSTALLATION

## PROCEDURE

1. Remove contents from box, verify if all parts listed are present and free from damage.

Carefully read and understand all instructions before attempting installation.

**Failure to identify damage before installation could lead to a rejection of any claim.**

2. Start installation by locating the Driver Mounting Bracket (Item 2). Align the bracket to the hole on the farthest side of the driver's side. Loosely install the bracket using the M8 hardware provided. **See Figure 1.**
3. Repeat step 2 for the Passenger Mounting Bracket (Item 1). **See Figure 1.**
4. Align and adjust the LED lights (Sold Separately) and brackets as necessary. Tighten and torque all M8 hardware to 16 ft-lbs.

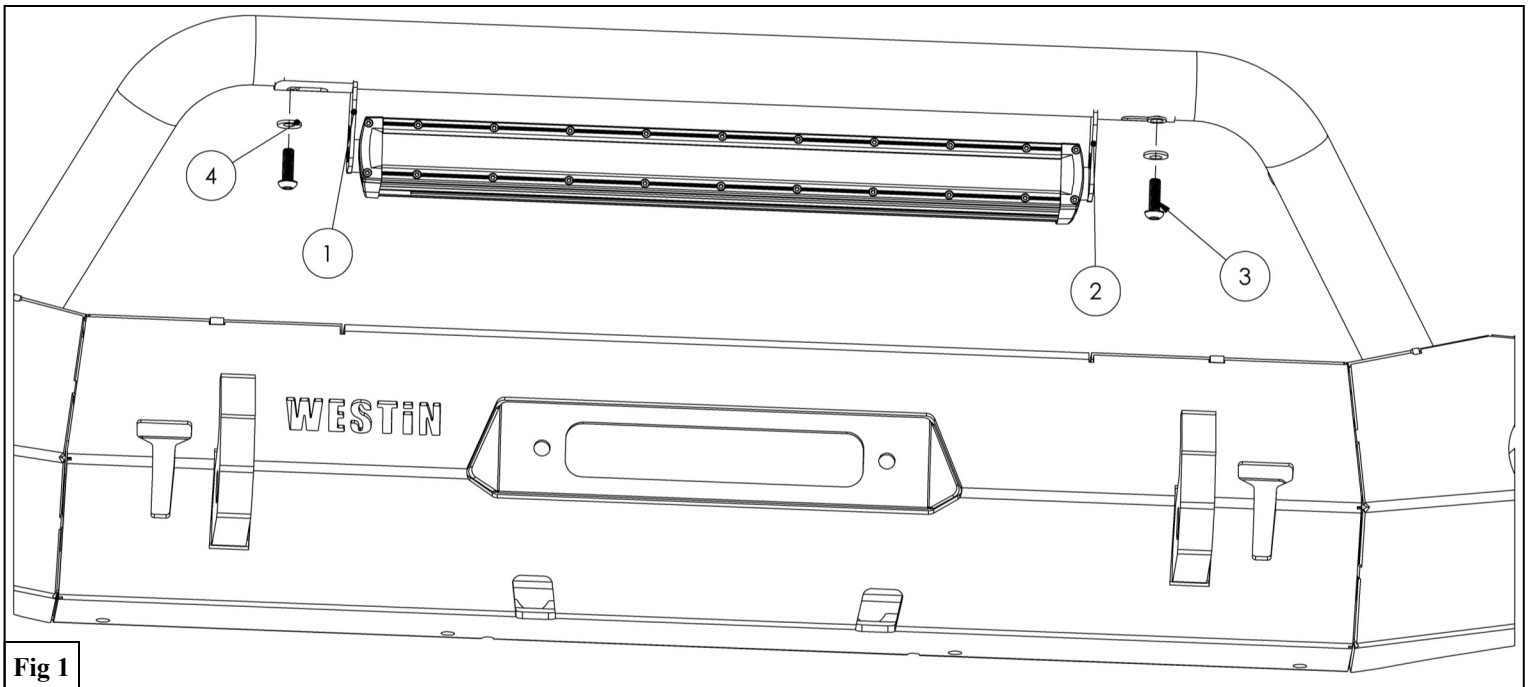

Fig 1



Westin Automotive Products, Inc.  
320 W. Covina Blvd  
San Dimas, Ca. 91773

Thank you for choosing Westin products  
for additional installation assistance please call  
Customer Service (800) 793-7846

## STUBBY BUMPER BRACKET INSTALLATION

### PROCEDURE

1. Remove contents from box, verify if all parts listed are present and free from damage.  
Carefully read and understand all instructions before attempting installation.  
**Failure to identify damage before installation could lead to a rejection of any claim.**
2. Start installation by locating the Driver Mounting Bracket (Item 1). Align the bracket to the hole on the farthest side of the driver's side. Loosely install the bracket using the M8 hardware provided. **See Figure 2.**
3. Repeat step 2 for the Passenger Mounting Bracket (Item 2). **See Figure 2.**
4. Align and adjust the LED lights (Sold Separately) and brackets as necessary. Tighten and torque all M8 hardware to 16 ft-lbs.

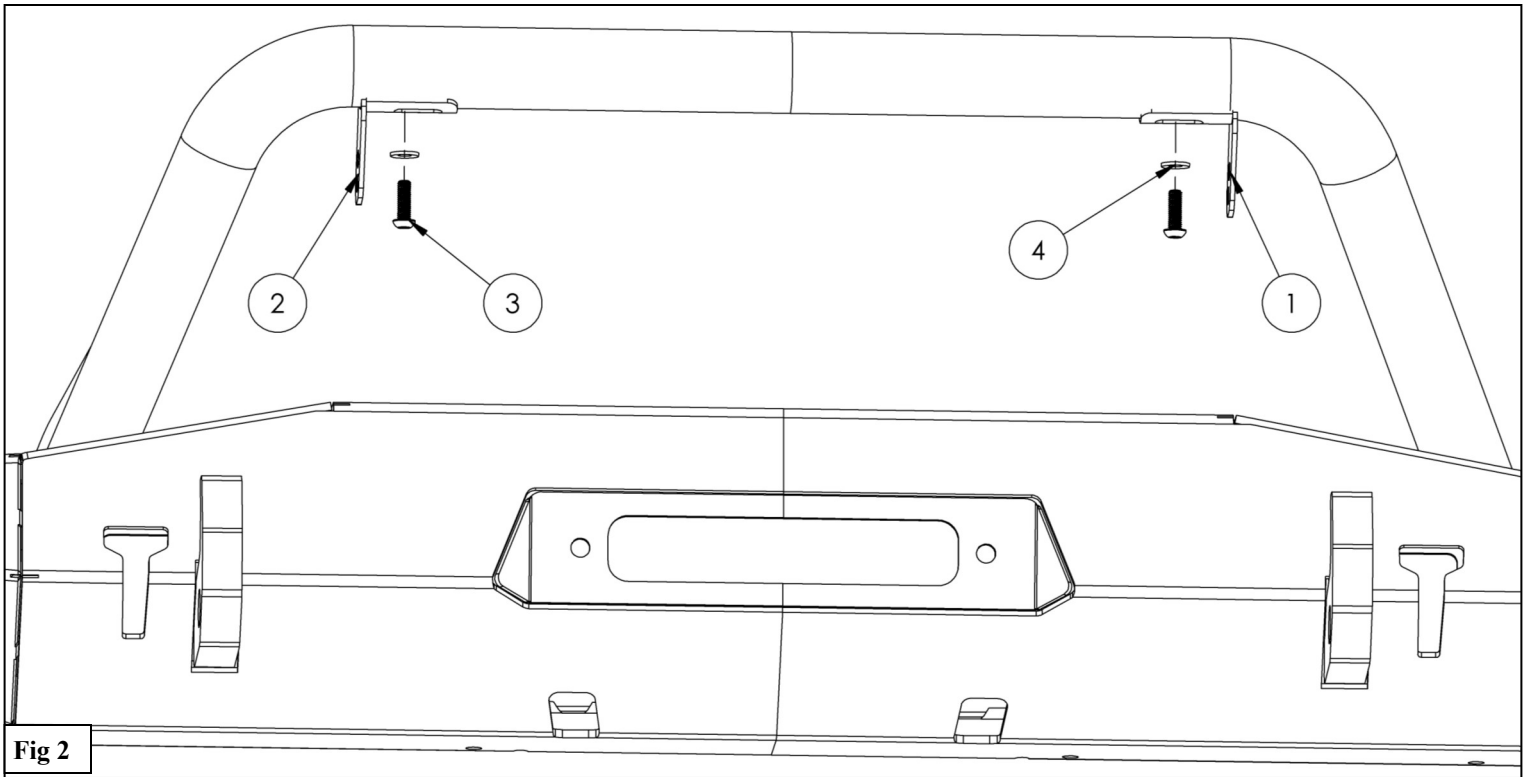

Westin Automotive Products, Inc.  
320 W. Covina Blvd  
San Dimas, Ca. 91773

Thank you for choosing Westin products  
for additional installation assistance please call  
Customer Service (800) 793-7846

**INSTALLATION COMPLETE**



Westin Automotive Products, Inc.  
320 W. Covina Blvd  
San Dimas, Ca. 91773

P.N.: 75-598801-RevA

ECO #: W17-0099

Thank you for choosing Westin products  
for additional installation assistance please call  
Customer Service (800) 793-7846  
[www.westinautomotive.com](http://www.westinautomotive.com)

DATE: 01/09/18