

INSTALLATION INSTRUCTIONS

REAR INNER FENDERS

WESTIN®

APPLICATION:
2007-2018 Jeep Wrangler JK (excl. JL)
PART NUMBER:
62-11015

CONTENT			
ITEM	QUANTITY	DESCRIPTION	TOOLS NEEDED
1,2	2	REAR INNER FENDER ASSEMBLY, DRIVER (1) AND PASSENGER (2)	10MM SOCKET
3,4	2	FRONT MOUNTING BRACKET, DRIVER (3) AND PASSENGER (4)	10MM WRENCH
5,6	2	REAR MOUNTING BRACKET, DRIVER (5) AND PASSENGER (6)	ALLEN WRENCH
7	4	M6 SERRATED FLANGE NUT	RATCHET
8	4	M6 HEX HEAD CAP SCREW	TORQUE WRENCH
9	4	SHORT M6 BUTTON HEAD SCREW	DRILL MOTOR
10	6	LONG M6 BUTTON HEAD SCREW	
11	14	M6 FLAT WASHER	
12	14	M6 SPLIT LOCK WASHER	
13	10	M6 U-CLIP	

ANTI-SEIZE LUBRICANT MUST BE USED ON ALL STAINLESS STEEL FASTENERS TO PREVENT THREAD DAMAGE AND GALLING

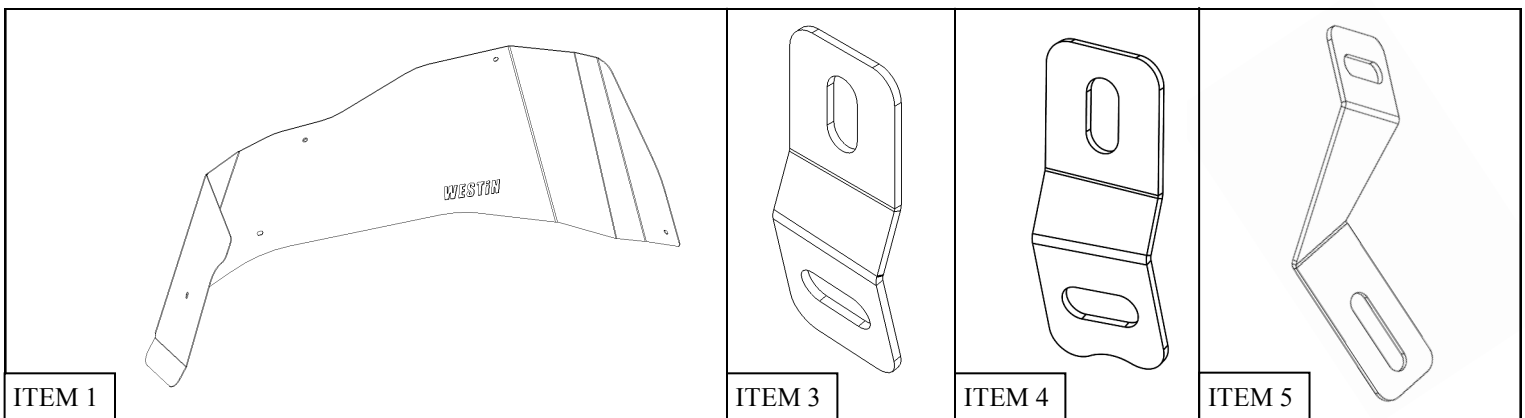

WARNING

Part # 62-11015 is designed to specifically fit with Westin Tube Fenders (Part # 62-1015). If reusing the factory fenders, **excessive** modification the factory parts is required. Modification may also be required for other aftermarket fenders

PROCEDURE

1. Remove contents from box, verify if all parts listed are present and free from damage.
Carefully read and understand all instructions before attempting installation.
Failure to identify damage before installation could lead to a rejection of any claim.

WESTIN Westin Automotive Products, Inc.
320 W. Covina Blvd
San Dimas, Ca. 91773

Thank you for choosing Westin products
for additional installation assistance please call
Customer Service (800) 793-7846
www.westinautomotive.com

2. Begin by removing the factory fender flares (if equipped).
3. First remove the tree clips holding the fender/fender liner in place. See **Figures 1 & 2**.



4. Remove the fender and fender liner as one piece. See **Figure 3**.
5. Remove all of the plastic retainer clips from the quarter panel.
6. Begin the Rear Inner Fender installation on the driver's side of the vehicle by installing a U-Clip (13) to the hole shown in **Figure 4**.



7. Attach a M6 U-clip (13) to each end of the Front Mounting Bracket (3) and loosely install to the inside of the wheel well using the supplied M6 hardware (8,11,12). See **Figures 5 & 12**.
8. Attach a M6 U-clip (13) to each end of the Rear Mounting Bracket (5) and loosely install to the inside of the wheel well using the supplied M6 hardware (8,11,12). See **Figures 6, 7, & 12**.

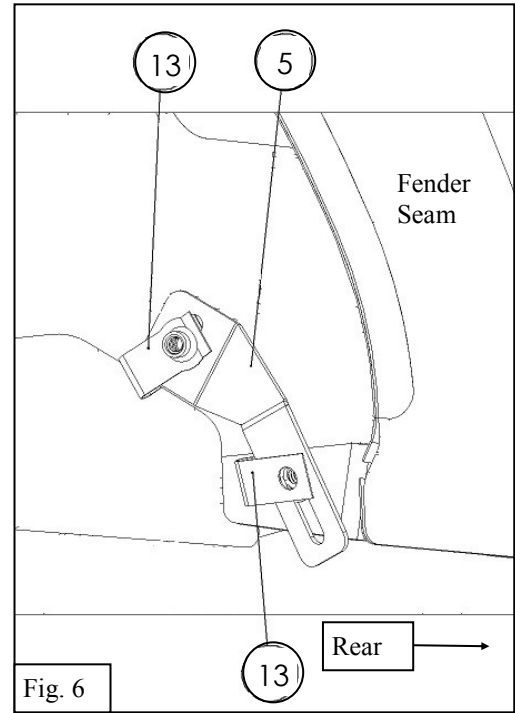
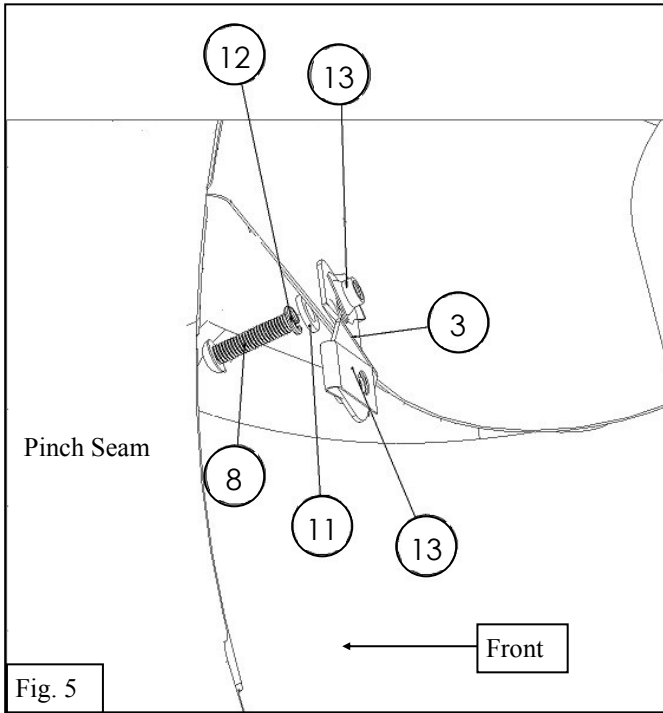

9. Next, install the Inner Fender (1) and line it up with the mounting brackets and U-Clip on the body of the vehicle. **Note:** It is necessary to bend the rear inner fender in order to place it inside of the wheel well. Removing the tire may make installation easier.

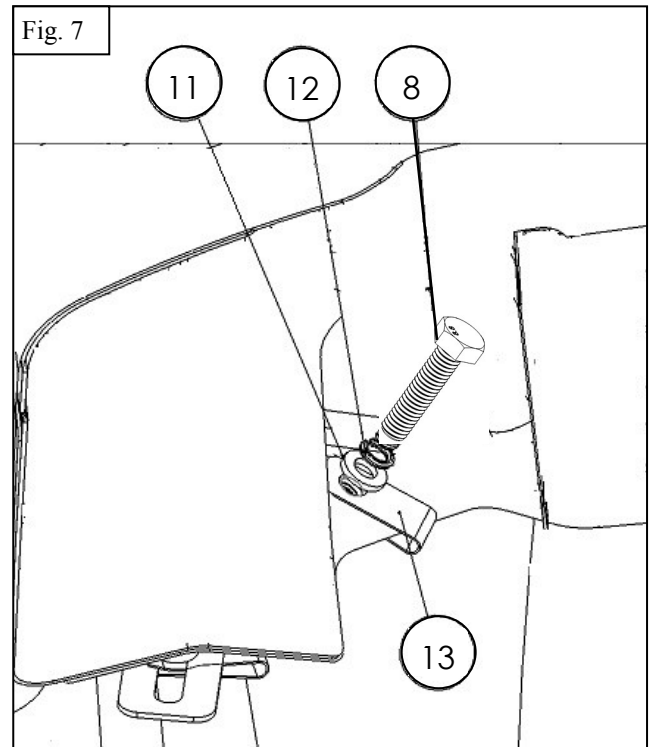

10. Secure with the provided M6 Hardware.
Note: Make sure that the top of the Rear Inner Fender is pressed up against the back of the wheel well. Use Short M6 Button Head Screws (9) to attach rear inner fender to brackets. See **Figures 8 & 9**. See **Figures 10 & 11** for M6 hardware model.

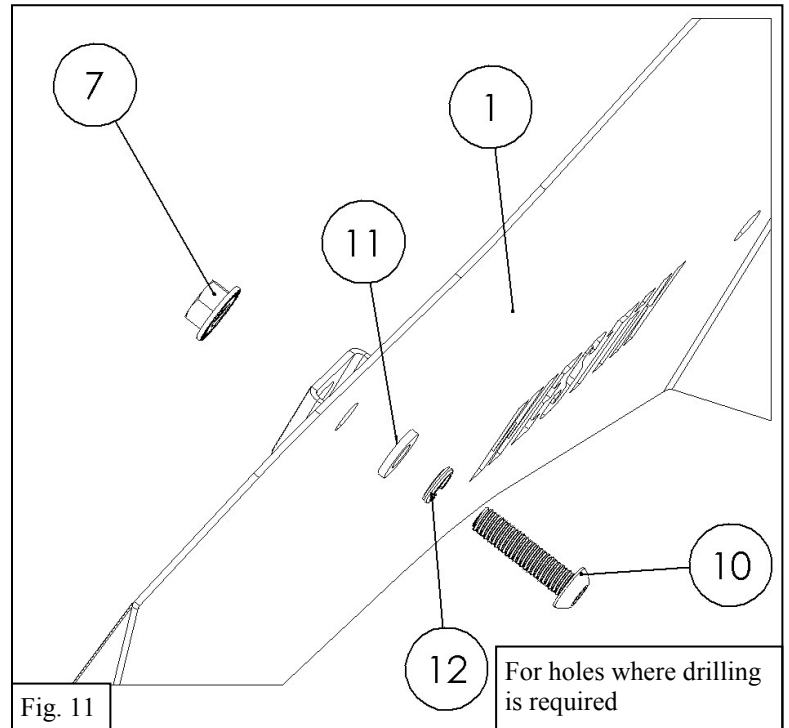
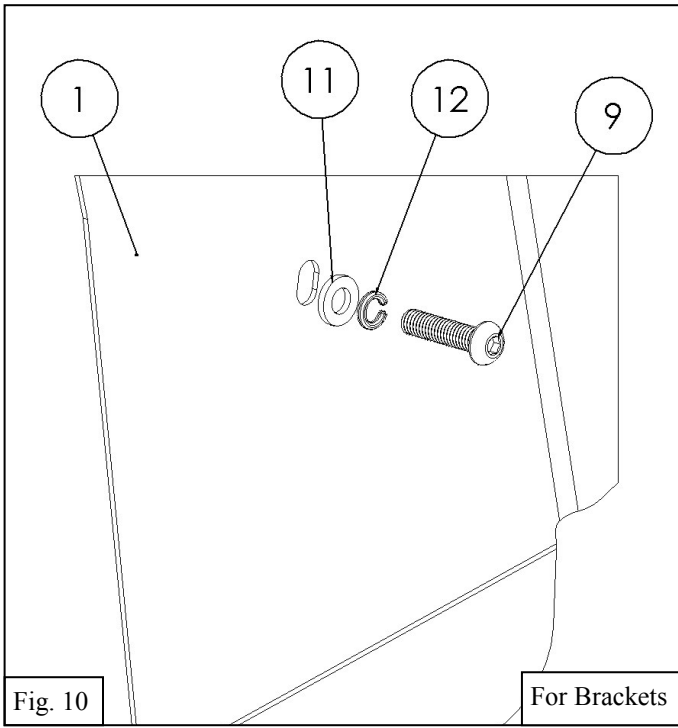
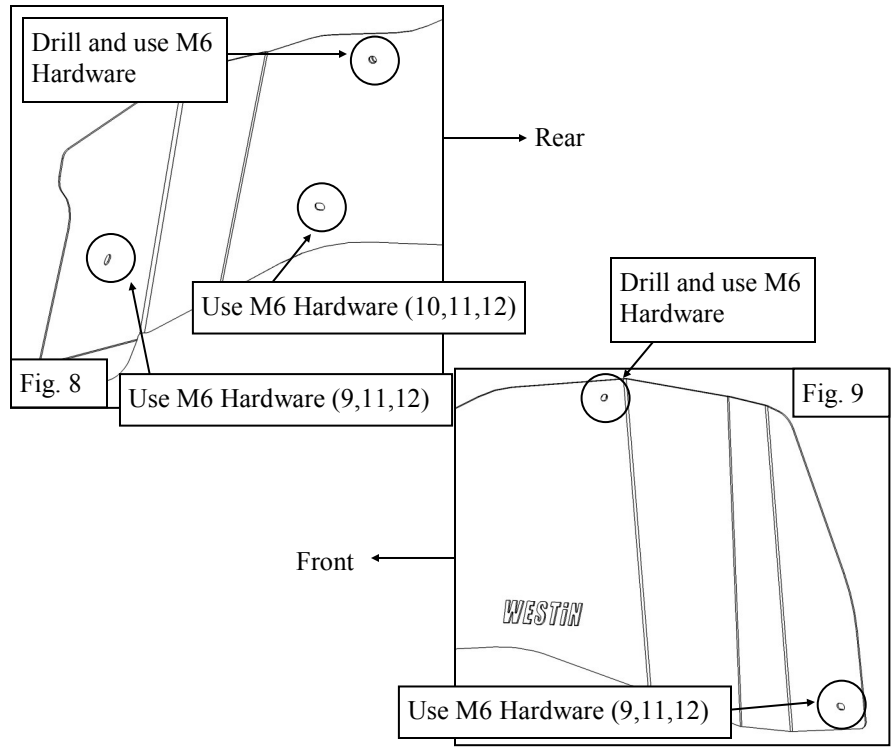

11. Drill two 1/4" holes in the wheel well at the location of the top two holes in the Rear Inner Fender. See **Figures 8 & 9**.
12. The holes that are drilled will receive a Serrated Flange Nut (7). To access this area, peel back the carpeting where the rear roll bar meets the tub of the vehicle. **Note:** Drilling location will be determined after the Inner Fender is secured in place. This will serve as a template for drilling. See **Figure 11**.
13. Tighten all M6 Hardware to 5-8 lb-ft.
14. Reinstall the trimmed OEM Fender or Aftermarket Fender.
15. Repeat **Steps 2-14** on the passenger side of the vehicle.

Fig. 12

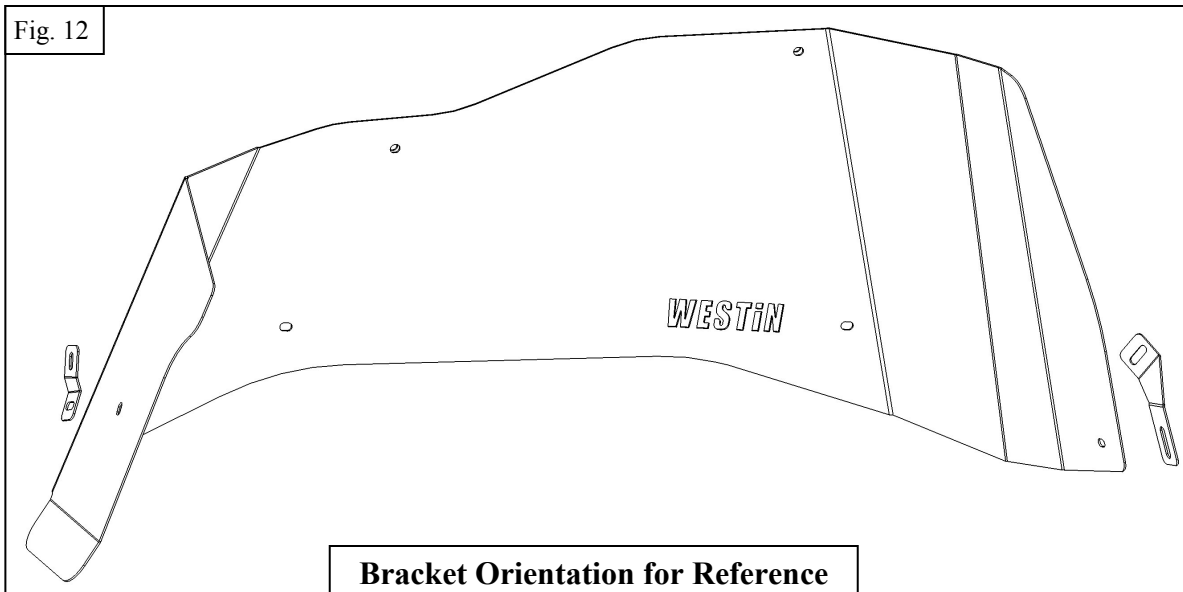

INSTALLATION COMPLETE



©2018 WESTIN AUTOMOTIVE PRODUCTS, INC. ALL RIGHTS RESERVED.

CARE INSTRUCTIONS

- REGULAR WAXING IS RECOMMENDED. DO NOT USE ANY TYPE OF POLISH OR WAX THAT MAY CONTAIN ABRASIVES
- STAINLESS STEEL PRODUCTS CAN BE CLEANED WITH MILD SOAP AND WATER. STAINLESS STEEL POLISH SHOULD BE USED TO POLISH SMALL SCRATCHES.
- GLOSS BLACK FINISHES SHOULD BE CLEANED WITH MILD SOAP AND WATER

WESTIN Westin Automotive Products, Inc.
320 W. Covina Blvd
San Dimas, Ca. 91773

Thank you for choosing Westin products
for additional installation assistance please call
Customer Service (800) 793-7846
www.westinautomotive.com



WARNING



Failure to follow these instructions could lead to death, personal injury, and / or property damage.

FASTENERS:

All Westin supplied fasteners must be utilized and installed in accordance with the installation instructions and apply torque to the specifications as defined. **DOUBLE CHECK ALL FASTENERS BEFORE INITIAL USE, AND PERIODICALLY IN THE FUTURE TO ENSURE PROPER FUNCTION AND SAFETY.**

DRILLING:

Most Westin products do not require drilling for installation. If drilling is defined as required, use caution when drilling a vehicle. **FAILURE TO REVIEW AN AREA TO BE DRILLED MAY RESULT IN PERSONAL INJURY AND/OR INJURY TO OTHERS AS WELL AS VEHICLE DAMAGE.**

EYE PROTECTION:

ALWAYS WEAR SAFETY GLASSES OR GOGGLES DURING THE INSTALLATION PROCESS TO AVOID PERSONAL INJURY.

MAXIMUM TOWING/CARRYING CAPACITY:

The Westin Receiver Hitches will have a visible tow rating label affixed directly on the product. User should never exceed the vehicle manufacturers maximum tow and weight rating regardless of the capacity of the hitch. **FAILURE TO FOLLOW THESE GUIDELINES WILL VOID THE WESTIN WARRANTY AND MAY RESULT IN PERSONAL INJURY AND/OR INJURY TO OTHERS AS WELL AS VEHICLE DAMAGE.**



Westin Automotive Products, Inc.
320 W. Covina Blvd
San Dimas, Ca. 91773