



INTERCOOLER SKID PLATE

RAM HEAVY DUTY

PLEASE READ ENTIRELY BEFORE YOU START

To guarantee a quality installation, we recommend reading these instructions thoroughly before beginning any work. These instructions assume a certain amount of mechanical ability and are not written nor intended for someone not familiar with auto repair.

TABLE OF CONTENTS

- I. Disassembly
- II. Installation

REQUIRED TOOLS

Common Hand Tools

NOTE: 3500 Trucks require a supplemental hardware kit.

AEV Part Number: 110602112AA

NOTE: A small group of Bumpers produced in early 2015 and prior have a lower flange on the intercooler shroud that will interfere with this Skid. If your vehicle is equipped with an early intercooler shroud with a lower flange, some modification is required (See Step I-3 to help identify whether or not your truck has this early part). Optionally: you may purchase a newer style shroud AEV Part Number: 10308010AB.



FRONT SKID

RAM HEAVY DUTY

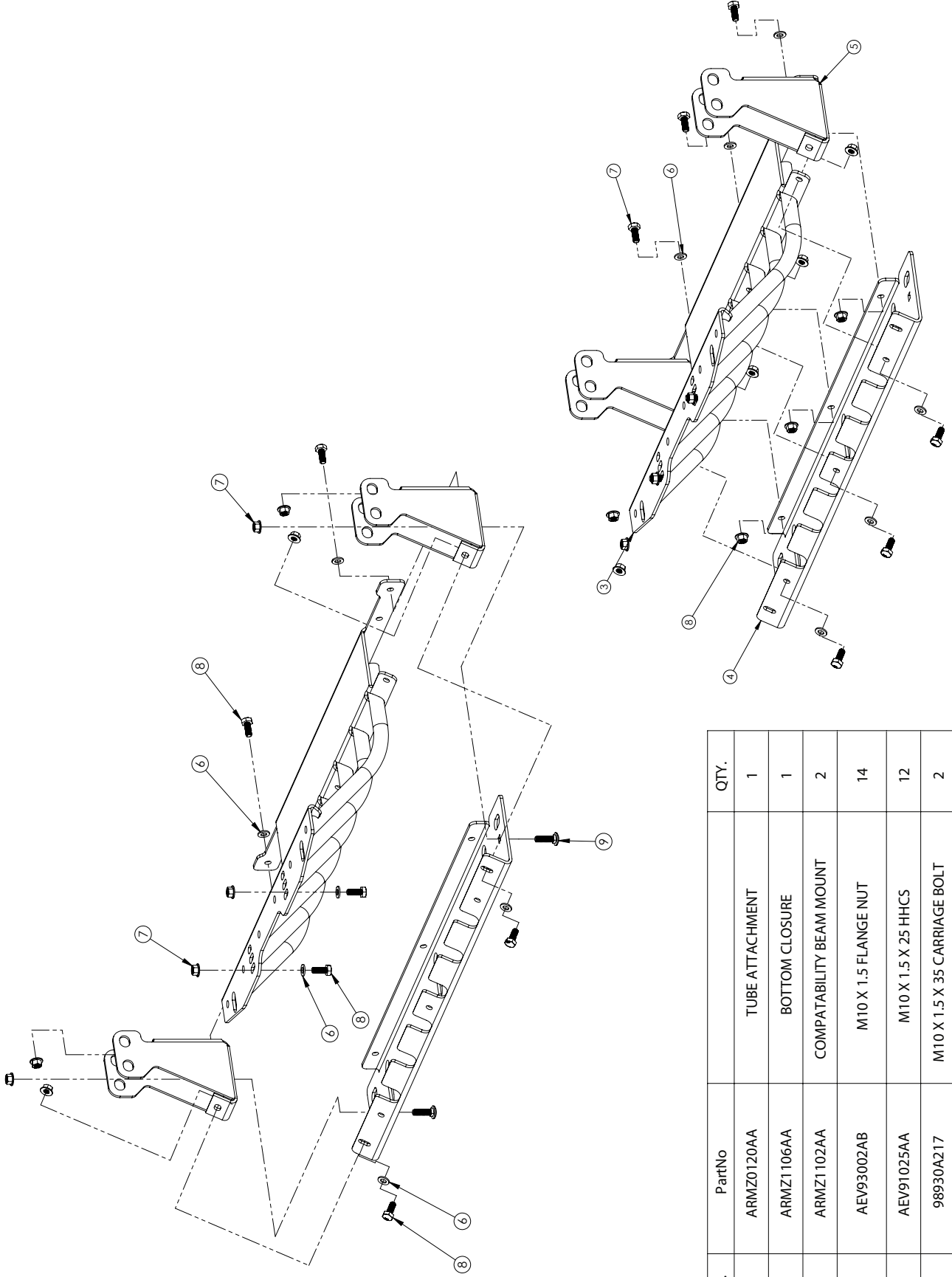

ITEM NO.	PartNo	DESCRIPTION	QTY.
1	ARMZ0120AA	TUBE ATTACHMENT	1
2	ARMZ1106AA	BOTTOM CLOSURE	1
3	ARMZ1102AA	COMPATABILITY BEAM MOUNT	2
4	AEV93002AB	M10 X 1.5 FLANGE NUT	14
5	AEV91025AA	M10 X 1.5 X 25 HHCS	12
6	98930A217	M10 X 1.5 X 35 CARRIAGE BOLT	2
7	AEV98001AB	M10 WASHER	12



I. DISASSEMBLY

1. If your vehicle is equipped with compatibility beams (fig. 1), remove the four bolts securing them to the frame. Save hardware. NOTE: We recommend applying rust prohibitor or paint to the exposed frame.

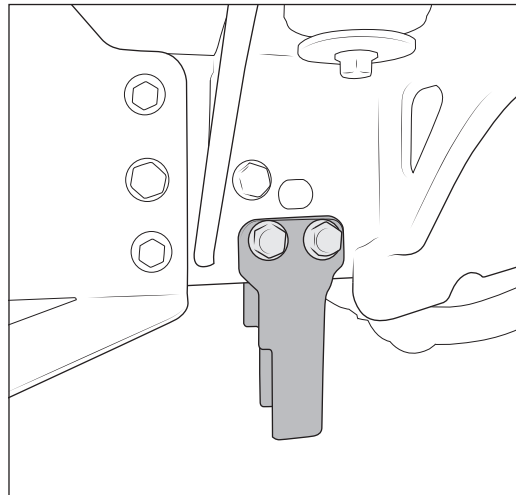

Figure 1

2. If installing after a winch is installed, remove the two underside bolts, being careful to keep track of the spacer that is located between the bumper and the winch (fig. 2). Save hardware.

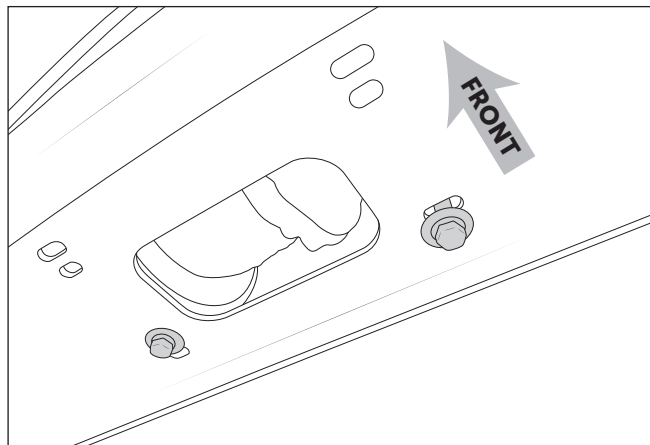

Figure 2



3. If your vehicle is equipped with an early intercooler shroud with a lower flange (fig. 3) you will need to trim the lower flange off along the bend and treat with rust preventative. Optionally: you can purchase a newer style shroud AEV Part Number: 10308010AB.

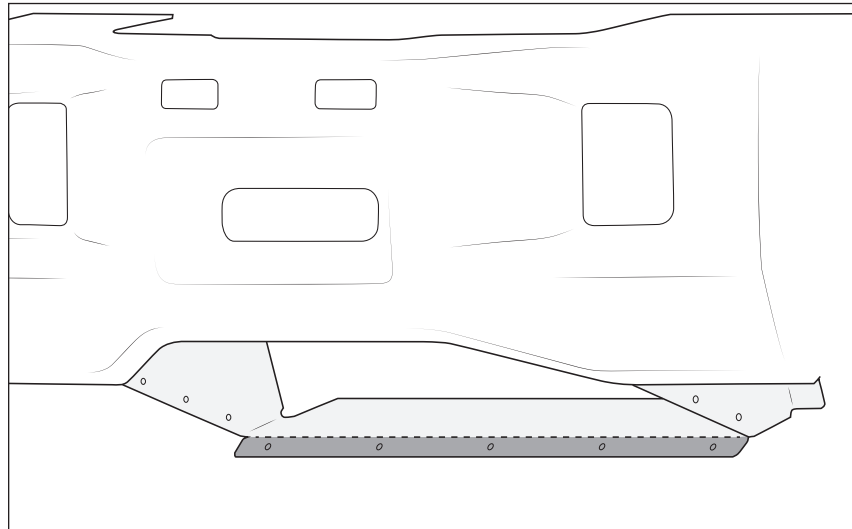

Figure 3: Trim Shaded Portion of Shroud

II. INSTALLATION

1. Loosely install the two AEV brackets using either the factory hardware saved in step one, or the AEV supplemental hardware kit PN: 110602112AA (fig. 4).

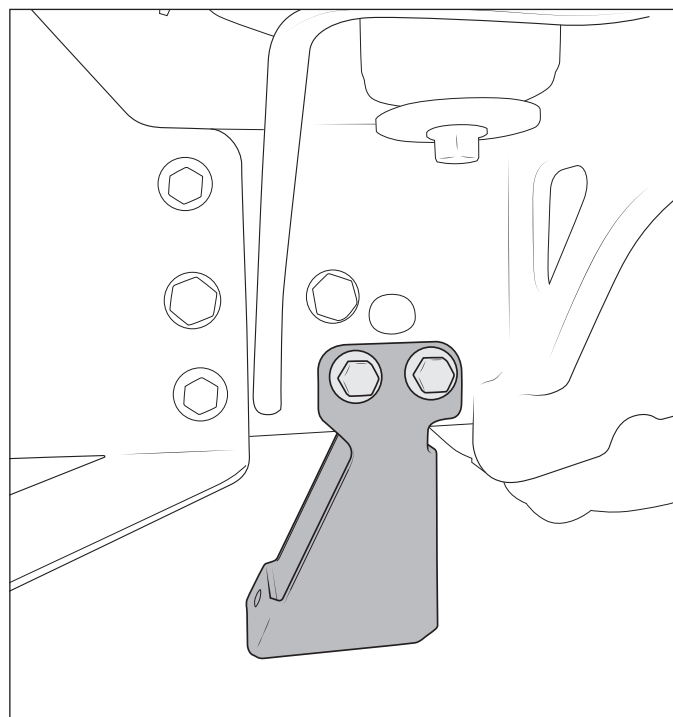

Figure 4



2. With a helper or use of a floor jack, lift the tubular skid into position. Loosely install the bolts saved from disassembly (Section I. Step 2), or the AEV supplied M10x25 hex head bolts, washers, and flange nuts into the underside of the AEV Front Bumper. Different hole locations will be used depending on the model year and winch setup of your truck.
 - A. For 2019+ trucks, the rearward hole on the bumper will be used (fig. 5).
 - B. For 2013 1/2 – 2018 trucks, the forward set of holes on the bumper will be used (fig. 6).
NOTE: In this position, the supplied M10x25 hex head bolts, washers, and flange nuts will need to be used. There is room for an open end wrench between the winch and bumper.

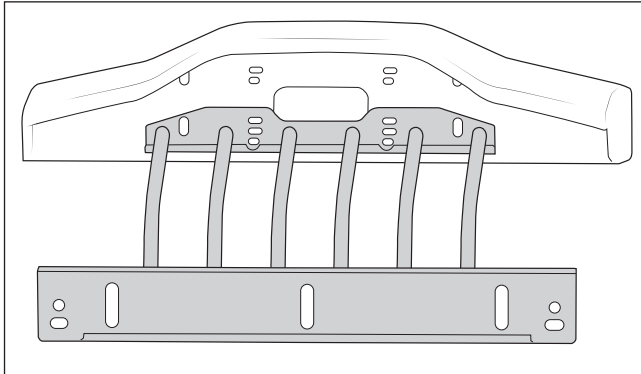

Figure 5

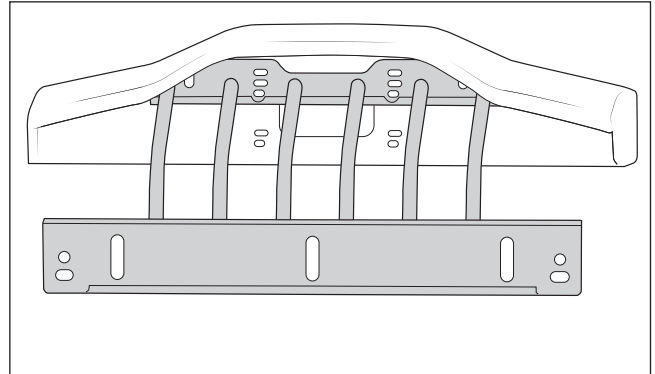

Figure 6

3. Lift the Closeout Plate into place and loosely install the two M10 x 35 carriage bolts through the close-out bracket and the bottom of the compatibility beam brackets. Use two of the supplied M10 flange nuts to secure the bolts (fig. 7).

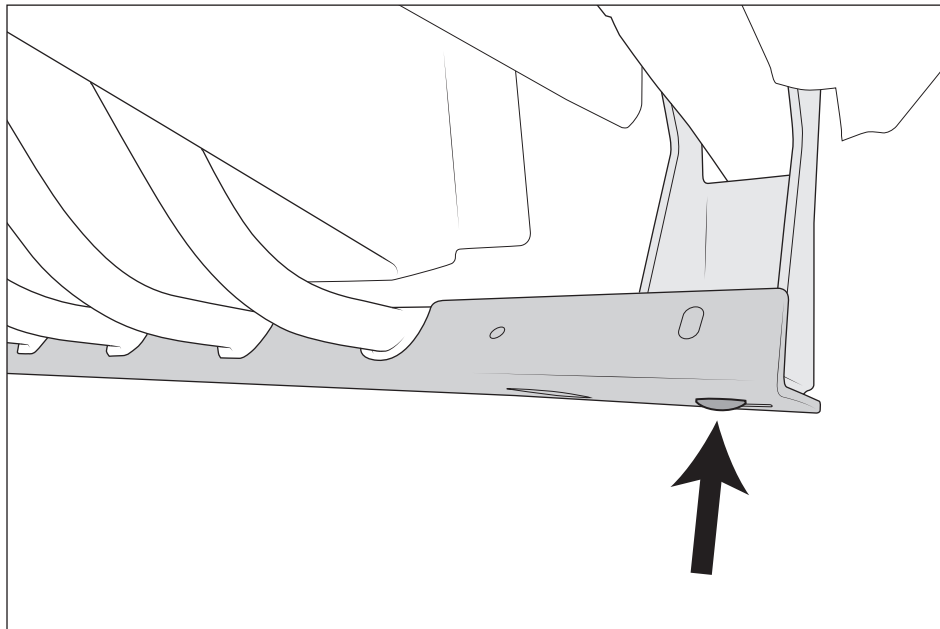

Figure 7



4. Install the ten supplied M10 x 25 hex head bolts, M10 washers, and M10 flange nuts into front and back sides of the Closeout Plate. It is recommended to start at the center and work outward. Tool access is provided using the slots on the bottom of the plate.

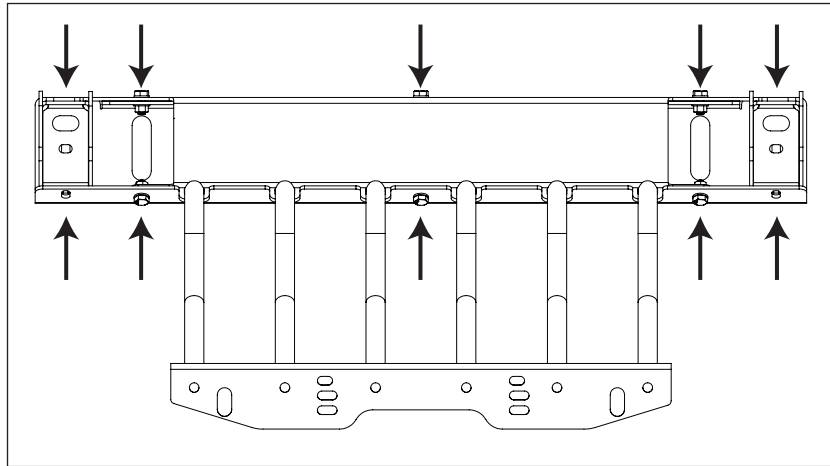

Figure 7: View from above

5. Torque the four nuts at the frame rails to 118 lb.-ft
6. Torque all of the M10 nuts to 43 lb.-ft