



Installation Instructions Bestop Rear Fender Flares

Vehicle Application:
Jeep® JL Wrangler, Wrangler Unlimited 2018 -
Current Part Number 49661

Installation

Bestop Rear Fender Flares can not be installed with factory wheel well liners. They can be installed without wheel well liners or Bestop Wheel Well Liners Part Number 4966301. If you will be installing Bestop Wheel Well Liners please proceed with 4966301 installation instructions.

WARNING The manufacturer strongly recommends that this product be professionally installed.

WARNING Failure to carefully follow the electrical installation steps could result in severe electrical shock which could harm the installer and/or damage the vehicle.

WARNING This product is designed primarily to enhance the appearance and comfort of the vehicle. Do not rely in any way on the components of this product to protect the occupants within the vehicle, or to protect against injury or death in the event of an accident. Never operate the vehicle in excess of manufacturer's specifications.



WEAR SEAT BELTS AT ALL TIMES

Tools and Supplies



Safety Glasses



10mm - 13mm
Wrenches



Power Drill



RivetNut Install Tool
(provided)

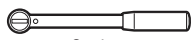

Socket
Wrench



8mm - 10mm -
13mm - sockets



10mm (25/64")
Precision Metal
Drill Bit



Masking Tape



4mm
Allen Key or HexTool
(Provided)

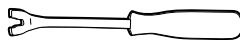

Panel Removal
Tool



Black RTV or
Exterior Caulk



OEM Matching
Touch-Up Paint



CAUTION

Safety glasses should be worn at all times when installing this product.

Installation Time



1-1/2 hours

Skill Level



3 - Moderately Difficult

Support

We're here to help! Go to:
<https://www.bestop.com>
and click on **Need Help?**



<https://www.bestop.com/video-library>



Installation Instructions Bestop Rear Fender Flares

Vehicle Application:
Jeep® JL Wrangler, Wrangler Unlimited 2018 - Current
Part Number 49661-01

Parts List

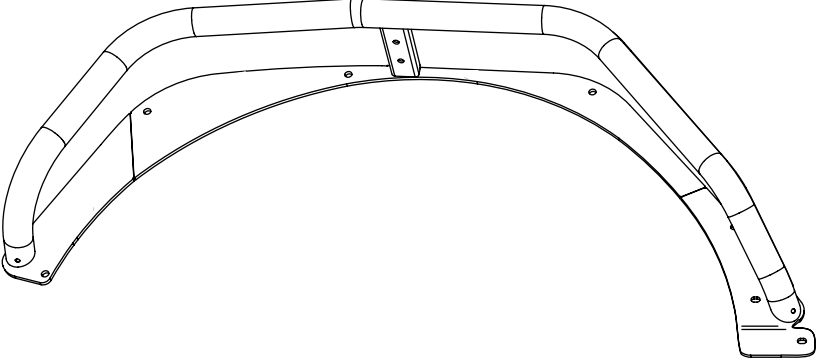
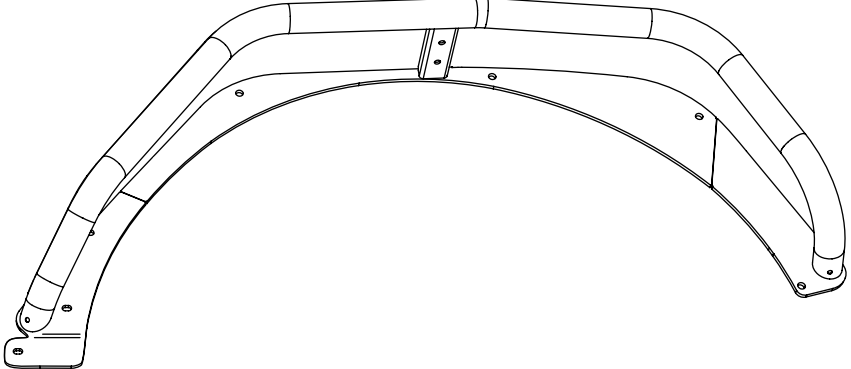
All Sections	Steel Tube Fenders
 <p>Rear Fender - Right (passenger) Side Part # 200303875 (matte finish) Qty. 1</p>	 <p>Rear Fender- Left (driver) Side Part # 200303880 (matte finish) Qty. 1</p>

Mounting Hardware Small Parts

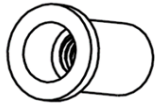

M6 x 14mm
Rivet-Nut
Part #3001676
Qty. 10



M6 x 25mm
Allen Bolt
Part #3000742
Qty. 14



M6 LockWasher
Part #3000136
Qty. 14

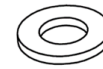

M6 Flat Washer
Part #3000288
Qty. 14

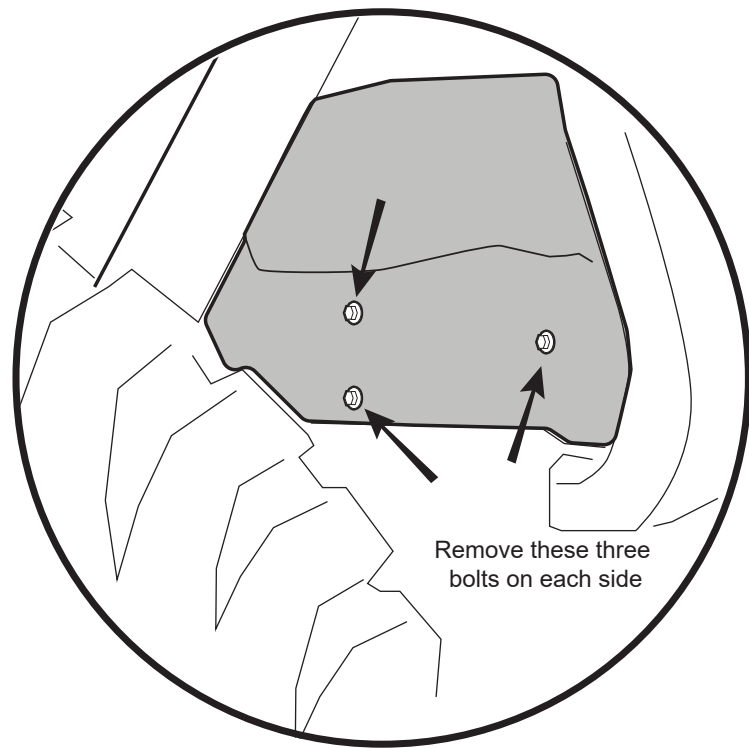
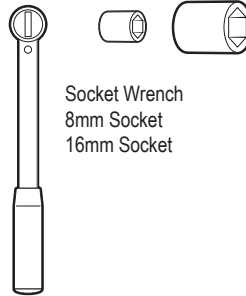

M6 Flange Nut
Part #3001569
Qty. 4

Tools**Step 1**

If equipt, remove the lower rear splash shield. It requires removing the three M8 bolts.

Remove the plastic shield from the bumper. It also has three M8 bolts attaching it..

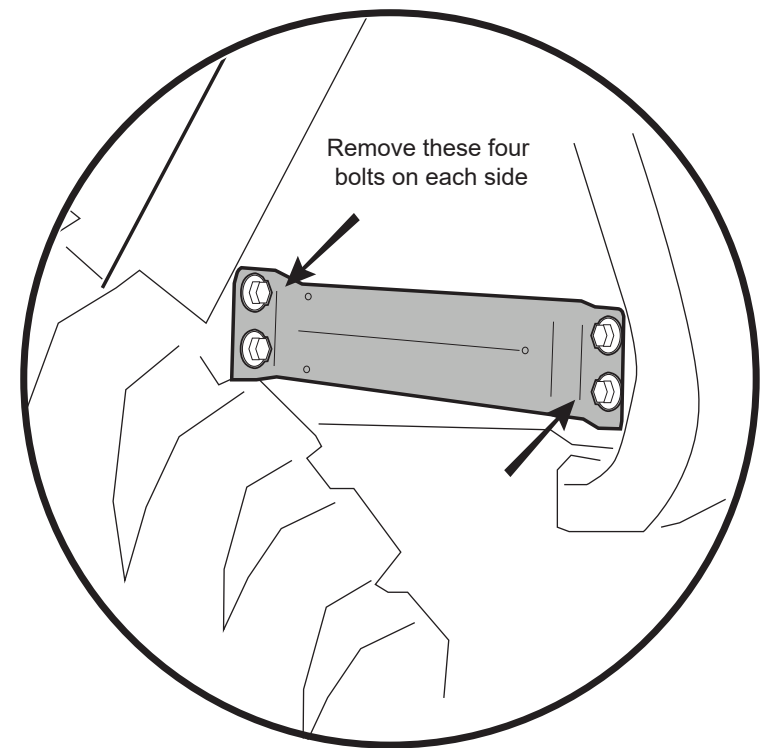
**Step 2**

Now remove the inner splash shield brace. There are two bolts at the bumper and two bolts at the frame to remove.

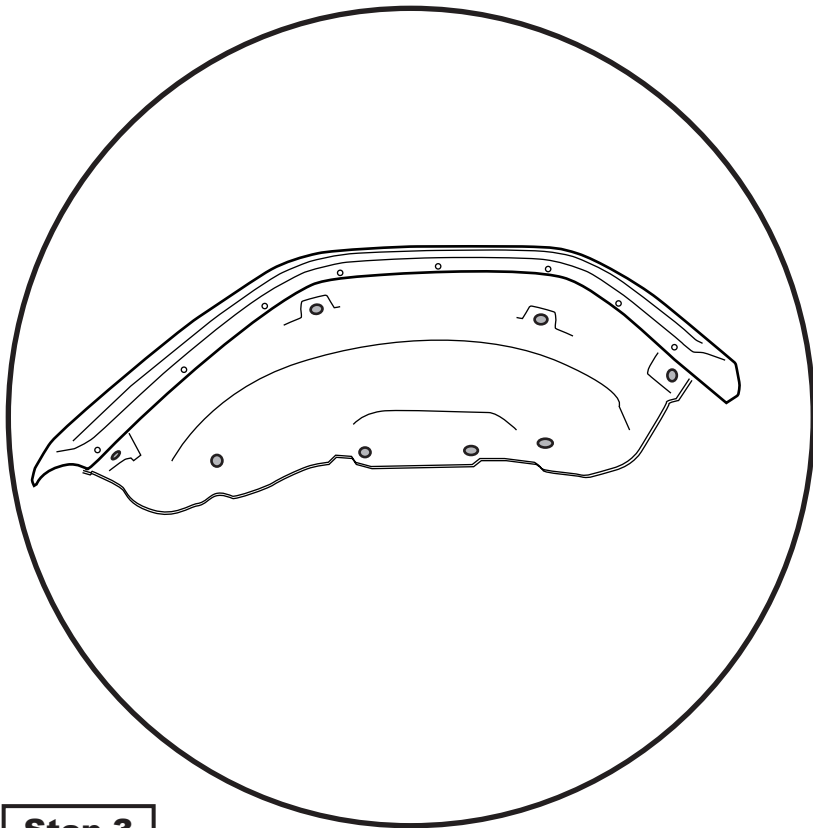

Tools

Panel Removal
Tool

Detail

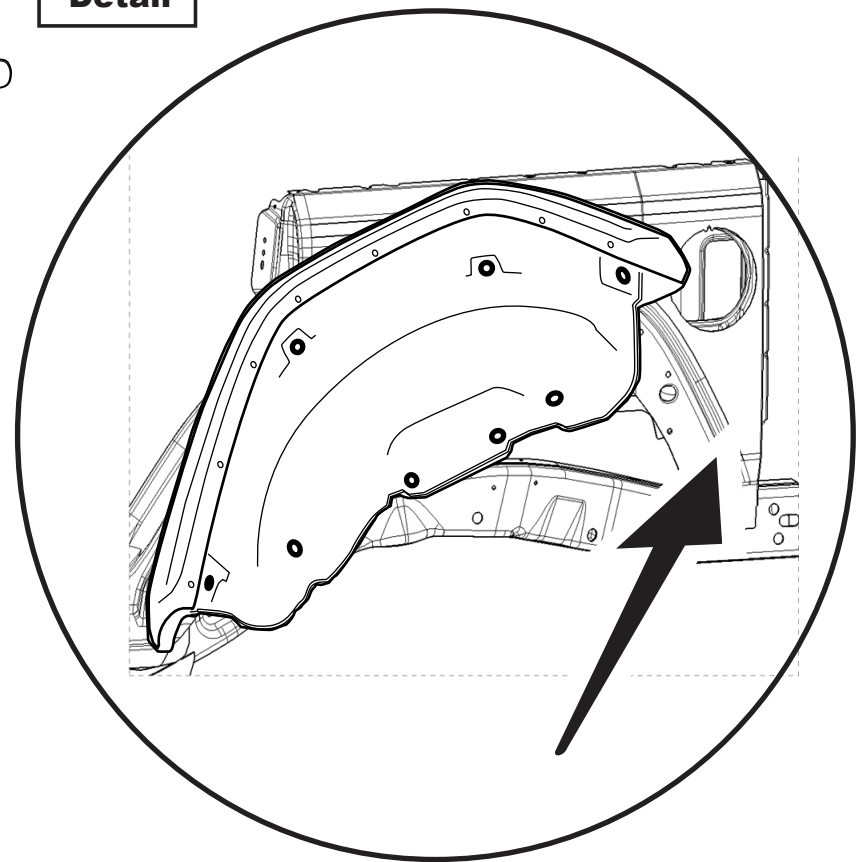

Step 3

On the OEM front fenders, it is easier to drill out the plastic rivets holding the liner to the fender. This is not needed on the rear.

To remove rear; start by releasing the inner fender liner retainers. Use a Panel tool to pry all the plastic trees that join the liner to the Jeep body.

It may be easier to cut the head of the retainer off with snips and remove. You will not reuse any of these fasteners..

With the inner liner fasteners removed and loose, now you can remove the entire fender. Grab the fender and pull the fender away from the body. It's attached with clips. When pulling it away the clips will probably break. Do not be concerned, you're not reusing them.

Start pulling from one corner and work your way to the other side of the fender.

With the OE fender and liner removed clean the body of the Jeep in this area. This is an opportunity for rust prevention or mediation.

Continue with rear fender flare installation w/wo Bestop Rear Wheel Liners.

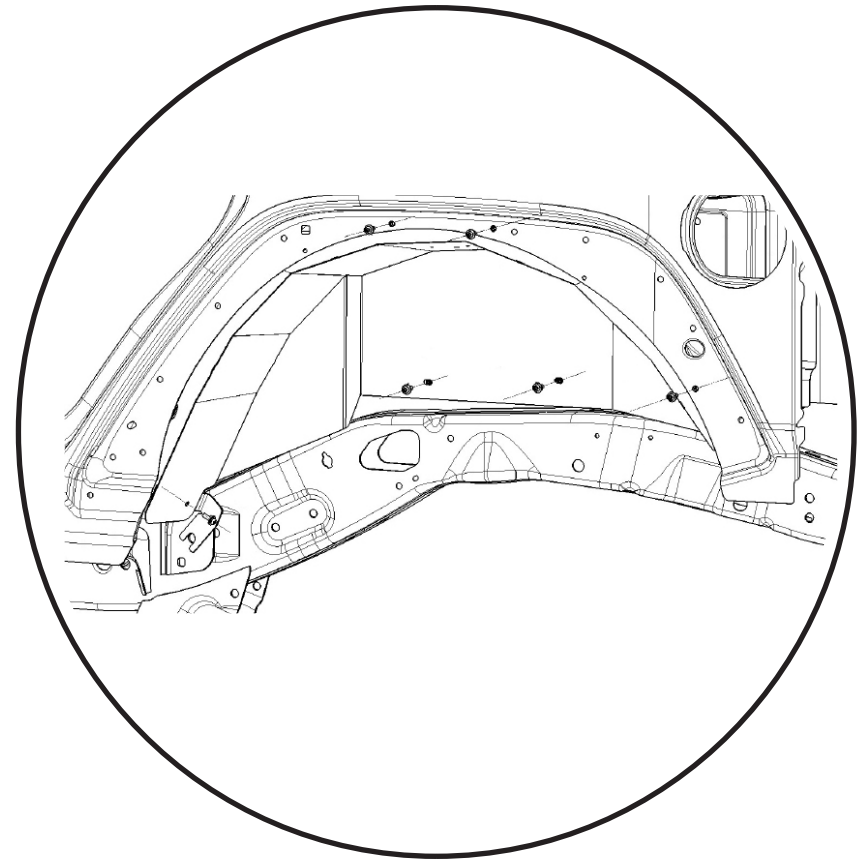
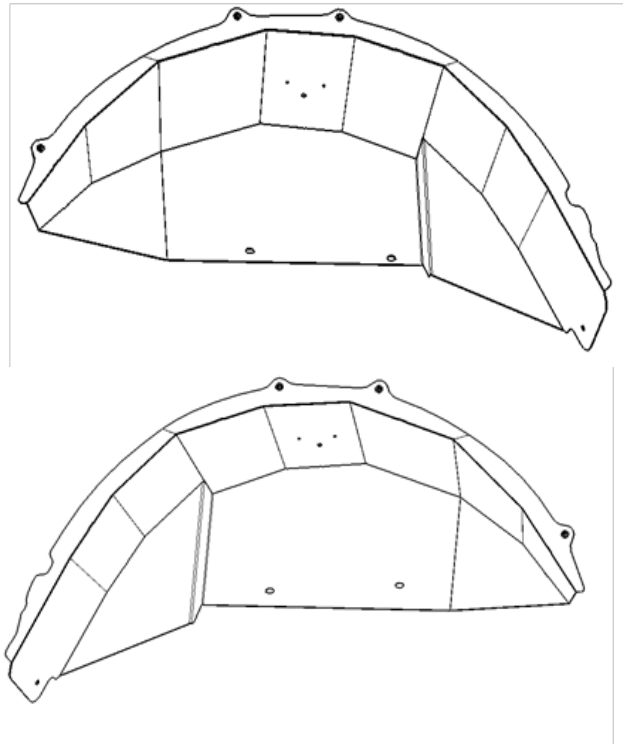

Continue with the Bestop Rear Fender Flare install sheet, from here on, unless you are not installing any Bestop Wheel Well Liners.

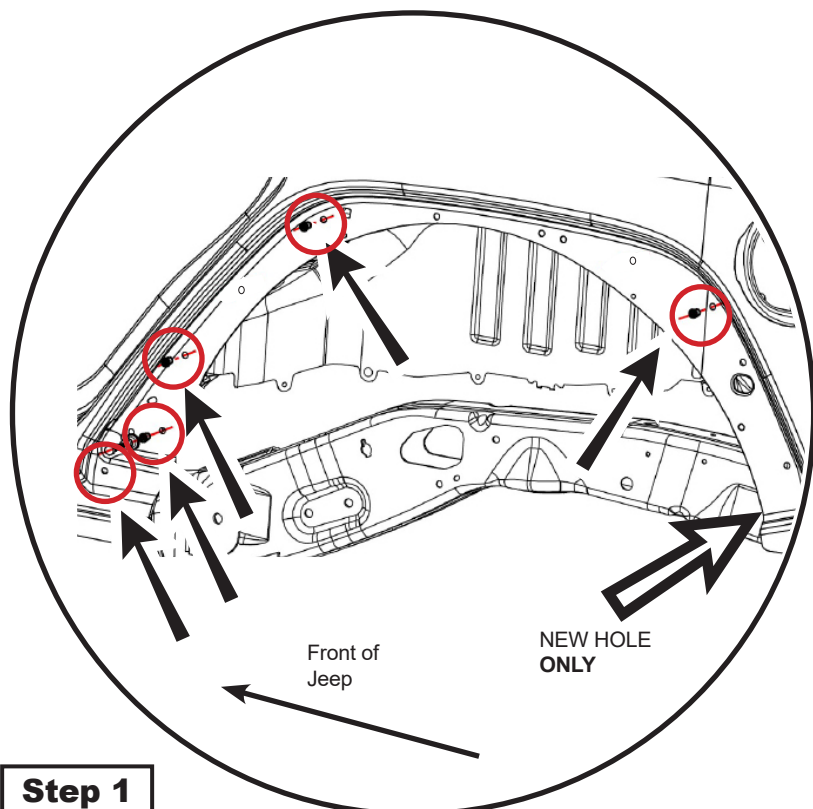

Step 1

In order to proceed, make sure that all the 5 holes (shown red) on each side of the vehicle are drilled, Use the 10mm (25/64") drill to open up these holes for the nutserts, and the holes are properly treated for metal protection.

Clinch the Rivet-Nut (Nutsert) to the body sheet metal in the 8 locations. Make sure your hardware stack-up is exactly as shown above. Take care, and be patient to avoid body damage / stripping. **To properly use the provided tool:**

- Back the reverse nut all the way to the head of the bolt.
- Install the Nutsert onto the threads of the bit, until it stops once the washer hits the limit collar.
- Press the full Stack-up into the hole in sheet metal
- Hold the Backer-Nut in position (13mm) and firmly into the sheet metal
- Tighten The bolt-tool head (13mm) until nutsert is fully clinched

Hardware

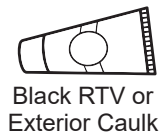

Tools

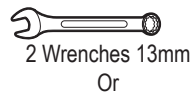

1 Wrench on Rivetnut
1 Socket on bolt head

Detail

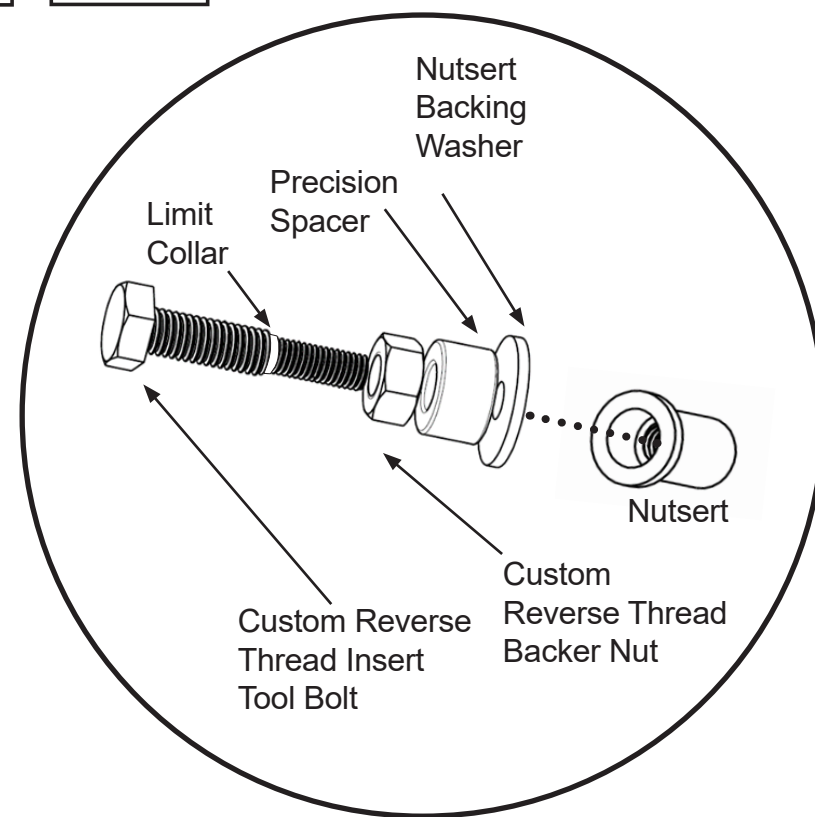

Detail

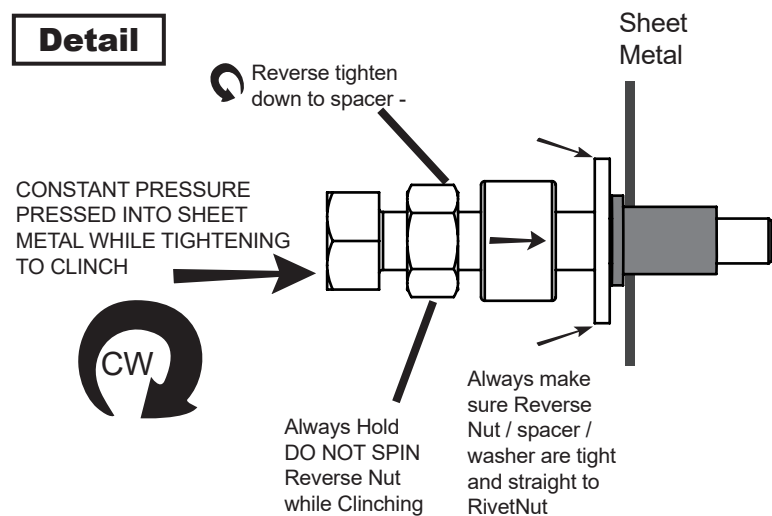

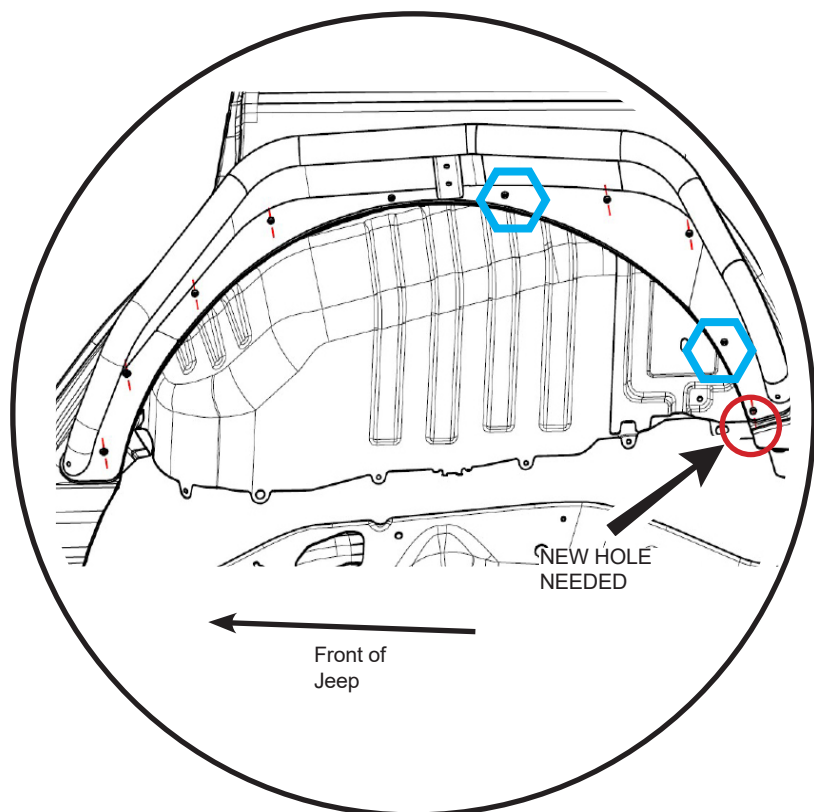

Hardware



M6 x 14mm
Rivet-Nut
Part #3001676
Qty. 10



OEM Matching
Touch-Up Paint



Black RTV or
Exterior Caulk



Masking Tape

Tools

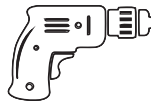

Power Drill
10mm or (25/64")
Precision
Metal Drill Bit



Socket Wrench
13mm Socket
4mm Hex Drive

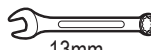

13mm
Wrenches

OPTION 1:

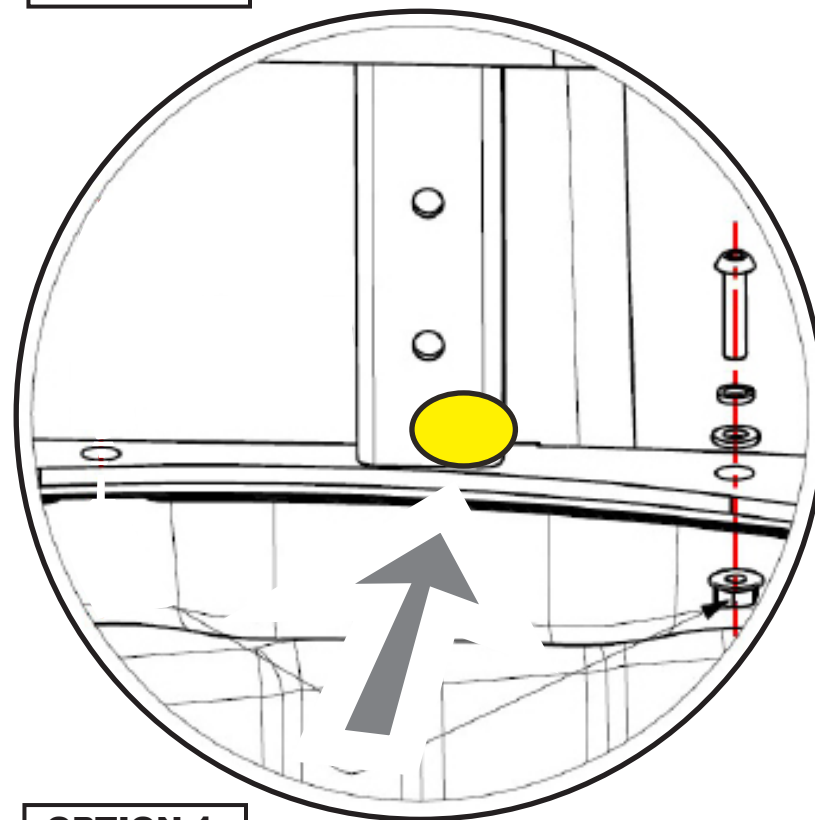

OPTION 1:

Mask off the body while you are prepping holes. Place the rear wheel flares to the wheel well and line up with the three holes (show HEX above left), so that you can temporarily insert bolts and nuts in place as a template, Make sure you press or lift up (as shown yellow above) the flare as you center all the holes in flare with the holes in the body. Then snug up the flare to the body. Use the 10mm drill bit to make the additional 9th hole for the new nutsert hole (as circled red above) using the flare flange as a drill-guide.

Remove Fender again, and prep holes to make sure you protect the exposed metal with properly applied and dried touchup paint, and Bestop recommends RTV as well., install nutserts and reinstall Proceed to Section 3 for Nutsert install process.

Mask off the body with tape while you are prepping holes. Make sure you protect the hole with properly applied and dried touch-up paint, and Bestop recommends RTV as well.

Option 1: (Bestop Recommended) Place the rear wheel flares to the wheel well and line up with the two holes so that you can temporarily insert bolts and nuts in place as a template, Make sure that all holes are centered, then tighten. Use 10mm drill to drill the nutsert hole using the flare flange as a drill-guide. Remove and prep holes, install nutserts and reinstall

- OR -

Option 2: Complete 7 of the 8 Rivet nutserts, use marker pen to mark the position of the 7th mounting hole, on the vehicle through the wheel flare (as circled red). Remove the fender and center punch and Drill, install Nutsert, then proceed.

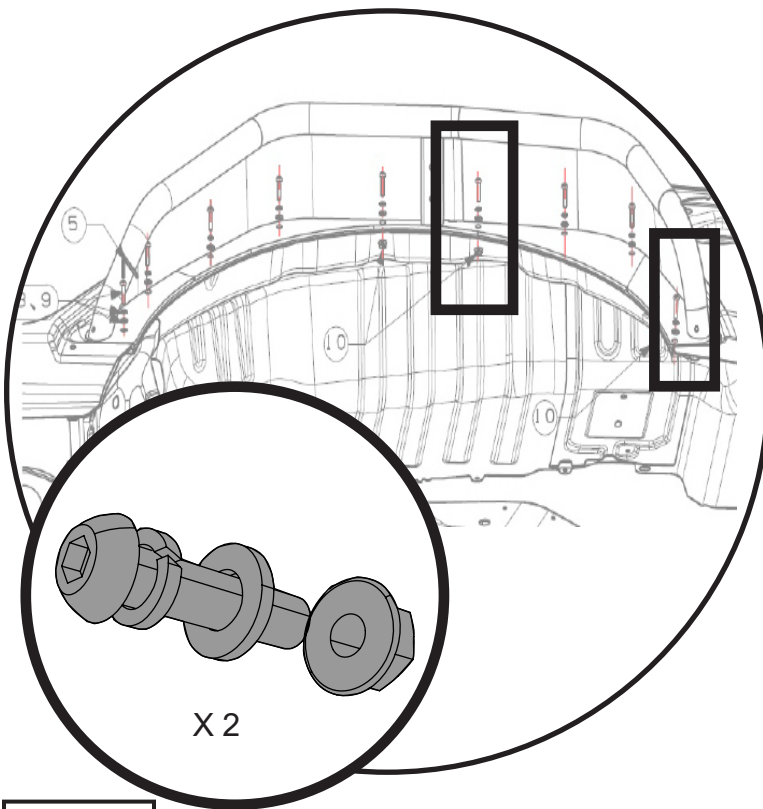

Step 1

Install Flares to vehicle:
By hand - tightening the M6 bolt (3000742), M6 Lock Washer (3000136), and M6 Flat washer (3000288) with the M6 Nut (3001569) on the backside of the body sheet metal.

NOTE: if you are installing with the Bestop Aluminum Fender well Liners (4996301) you will be installing directly into the Rivetnut that are on that assembly.

DO NOT TIGHTEN WITH TOOLS YET.
You will need to have the fenders loose incase of needed

Hardware



M6 x 25mm
Allen Bolt
Part #3000742
Qty. 14



M6 LockWasher
Part #3000136
Qty. 14



M6 Flat Washer
Part #3000288
Qty. 14



M6 Flange Nut
Part #3001569
Qty. 4

Tools



4mm
Allen Key or HexTool
(Provided)

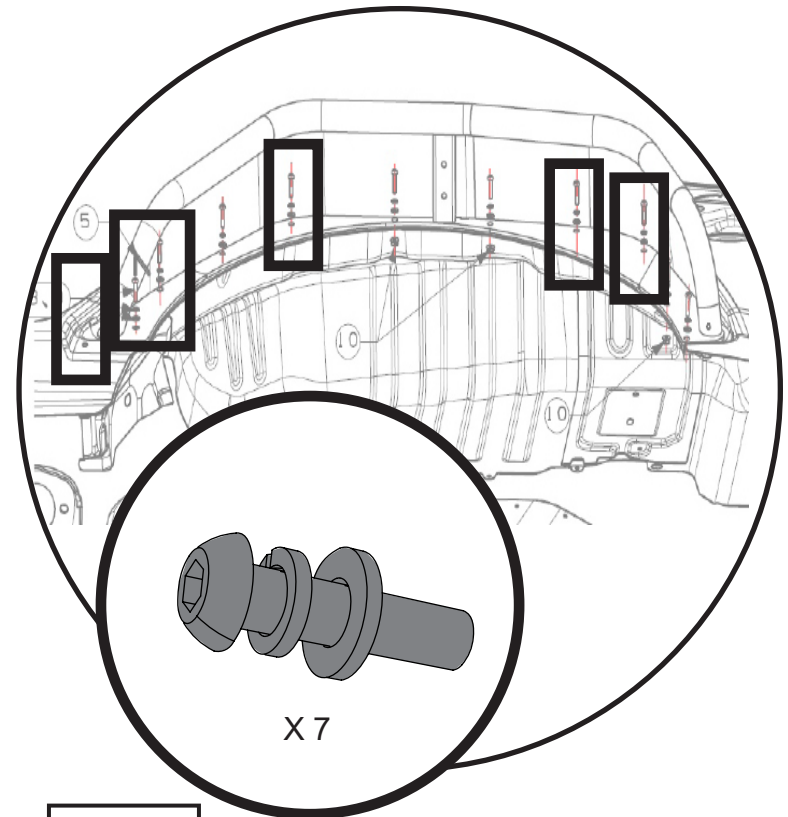

Step 2

Continue to install Flares to vehicle:
By hand - tightening the M6 bolt (3000742), M6 Lock Washer (3000136), and M6 Flat washer (3000288).

Torque all hardware to 8 in/lb. (10.5 Nm)



Installation Instructions Bestop Rear Fender Flares

Vehicle Application:
Jeep® JL Wrangler, Wrangler Unlimited 2018 -
Current Part Number 49661

WHAT BESTOP WARRANTS

Subject to the terms and conditions of sale, including any terms and conditions set forth by Bestop, Inc. (“Bestop” or “us” or “we”) in our then-current terms of sale on our website (collectively, the “Terms”), Bestop represents and warrants that: the covered products listed in the “Covered Products and Warranty Periods” section (a “Product”) will substantially be free from defects in materials and workmanship for the specified warranty periods set forth in that section.

THE WARRANTY IS LIMITED AND CONDITIONAL

This warranty applies to the original purchaser of the Product only. The warranty is valid only as long as the original retail purchaser owns the vehicle upon which the Product is installed. The warranty expires should the Product be removed from the original vehicle or if the original vehicle is transferred to another owner. This warranty is not transferable or assignable. The warranty does not apply to Product bought from auction-style or price-bid websites.

THE LIMITED WARRANTY AND STATED REMEDIES ARE SOLE AND EXCLUSIVE AND IN LIEU OF ALL OTHER WARRANTIES AND REMEDIES, AND COMPANY EXPRESSLY DISCLAIMS ALL IMPLIED OR STATUTORY OR OTHER WARRANTIES, INCLUDING WITHOUT LIMITATIONS WARRANTIES OF MERCHANTABILITY, NON-INFRINGEMENT OR FITNESS FOR A PARTICULAR PURPOSE. IN NO EVENT WILL COMPANY BE LIABLE FOR ANY SPECIAL, INCIDENTAL, CONSEQUENTIAL, PUNITIVE, INDIRECT OR EXEMPLARY DAMAGES OF ANY KIND, INCLUDING LOST PROFITS OR REVENUE, HOWEVER CAUSED, WHETHER FOR BREACH OR REPUDIATION OF CONTRACT, TORT, BREACH OF WARRANTY, NEGLIGENCE, OR OTHERWISE, WHETHER OR NOT COMPANY WAS ADVISED OF THE POSSIBILITY OF SUCH LOSS OR DAMAGES.

Some states do not allow exclusion or limitation, so this may not apply to you. This warranty gives you specific legal rights, and you may have other rights which vary from state to state.

EXCLUSIONS TO THE WARRANTY

The Limited Warranty excludes, and Bestop is not liable in any way for any warranty claims, damages, or defects related to:

- Misuse, abuse, accidents, vandalism, negligence, fire, or improper installation or modification, or improper or inadequate maintenance;
- Failure to comply with any Product documentation, Bestop instructions, or applicable law or regulations; use in extreme conditions
- Force Majeure including but not limited to, earthquake, hurricane, tornado, flooding, or other disasters natural or man-made, civil unrest, strikes, declared or undeclared war, or lack of performance by, or discontinued product of, supply chain partners whose products, software, operations or management is beyond the control of Bestop;
- Damage resulting in breakage (including without limitation, spontaneous breakage, accidental breakage or breakage by any other means) of a Product or any component part;
- Damage to vinyl windows due to misuse, or cracking due to varying weather conditions.

YOUR SOLE REMEDY

During the applicable warranty period, Bestop shall, at its option, either repair or replace any Product that it confirms, in its discretion, is non-compliant with the warranties herein. Bestop will not pay for labor charges associated with installation or removal of the Product. Should a specific Product be discontinued, Bestop may, at its option, replace the discontinued Product with a current product or like product.

Please retain your proof of purchase. Original proof of purchase for the Product must accompany any warranty claim. If you have a warranty claim, first you must email Bestop Customer Service at csbestop@bestop.com for instructions. All claims must be emailed to csbestop@bestop.com within 30 days of discovery of a defective Product, but in no event later than thirty days after the end of the applicable Warranty Period (the “Warranty Notice Period”). Warranty claims made after the Warranty Notice Period are null and void and Bestop shall have no responsibility with respect to such claims.

THIS SECTION SETS FORTH BESTOP'S SOLE OBLIGATION & YOUR SOLE REMEDY WITH RESPECT TO ANY DEFECTS OR OTHER PRODUCT ISSUE. ANY PRODUCTS REPLACED UNDER TERMS OF THIS WARRANTY WILL BE COVERED UNDER TERMS & BALANCE OF THE DURATION OF THE ORIGINAL LIMITED WARRANTY FOR SUCH PRODUCT.



Installation Instructions Bestop Rear Fender Flares

Vehicle Application:
Jeep® JL Wrangler, Wrangler Unlimited 2018 -
Current Part Number 49661

COVERED PRODUCTS AND WARRANTY PERIODS: The warranty time periods are as follows for Products manufactured by Bestop:

BESTOP® LIMITED LIFETIME WARRANTY

Trektop® Pro Twill Fabric Top Sunrider® for Hardtop Twill Fabric Top
Trektop® NX Glide Twill Fabric Top Replace-a-Top™ Twill Fabric Top
Trektop® NX Twill Fabric Top Supertop® NX Twill Fabric Top
EZFold™ Soft Tonneaus Floor & Cargo Liners
ZipRail™ Soft Tonneaus Pet Barriers
EZRoll™ Soft Tonneaus

BESTOP® 5-YEAR LIMITED WARRANTY

Trektop® NX Glide™ Top (non-Twill) Sunrider® for Hardtop (non-Twill) Replace-a-Top™ Top (non-Twill) Trektop® NX Top (non-Twill)
Sailcloth Replace-a-Top™ Supertop® NX Top (non-Twill)
Tigertop™ and Halftop™ Supertop® Classic Soft Top Sunrider® Complete Soft Top Supertop® for Truck
EZ Fold Hard Tonneau

BESTOP® 3-YEAR/100K MILES LIMITED WARRANTY

Powerboard® & Powerboard® NX

Trekstep®, Side Mount
Trekstep®, Rear Mount

BESTOP® 3-YEAR LIMITED WARRANTY

Pavement Ends Sprint Top

BESTOP® 2-YEAR LIMITED WARRANTY

Trektop® Classic Soft Top
RoughRider™ Soft Storage

BESTOP® 1-YEAR LIMITED WARRANTY

All other Bestop® & Pavement Ends™ products not specified above.

For further information or request for warranty work, please contact:

Bestop Inc. Customer Service

Toll-Free: (800)845-3567

Main: (303)465-1755

E-mail: csbestop@Bestop.com

Website: www.Bestop.com