



Installation Instructions Supertop for Trucks

Vehicle Application:
Ford F-150 2015-Current 6.5' Bed
Part Number 77336

Installation Tips

Before you begin installing your new Supertop for Trucks, please read all the instructions thoroughly.

It is recommended that two people install this Bestop product.

For a smooth fit:

For easier installation, the top should be installed at a temperature above 72° F. Below this temperature, the fabric may contract an inch or more, making it difficult to fit the vehicle. You may let the fabric sit in the sun for 15-20 minutes before installing to let the fabric warm up.

It is normal for the fabric to contract and wrinkle when stored in the shipping carton. Within a few days after installation, the fabric will relax and the wrinkles will disappear.











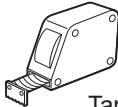

WARNING Do not rely in any way on the components of this product to protect against injury or death in the event of an accident. Never operate the vehicle in excess of manufacturer's specifications.

Read and follow, precisely, all installation instructions provided when installing this product. Failure to do so may result in a poor fit and could place occupants of the vehicle in a potentially dangerous situation.



CAUTION Safety glasses should be worn at all times when installing this product.

WEAR SEAT BELTS AT ALL TIMES

| Tools | | | | Installation Time | | Support | |
|---|---|--|---|---|--|--|--|
|  Ratchet |  9/16" Socket | - OR - |  9/16" Wrench |  Tape Measure |  2 hours | We're here to help! Go to: https://www.bestop.com and click on Need Help? | |
|  Safety Glasses |  1/8" Allen Wrench |  Utility Knife |  T20 Torx Driver Qty. 1 | Skill Level | |  | |
|  Pliers |  Phillips Screwdriver |  Torque Wrench |  3 - Moderately Difficult | https://www.bestop.com/video-library | | | |



Installation Instructions Supertop for Trucks

Vehicle Application:
Ford F-150 2015-Current 6.5' Bed
Part Number 77336

Sugerencias de Instalación

Antes de empezar a instalar esta unidad, lea atentamente todas las instrucciones.

Para un buen ajuste:

Para facilitar la instalación, el producto debe instalarse a temperaturas superiores a 72 °F (22 °C).

Por debajo de esta temperatura, la tela puede encogerse una pulgada o más, lo que dificultaría su ajuste al vehículo.

Es normal que la tela se contraiga o arrugue cuando está guardada en la caja de empaque. A los pocos días después de la instalación, la tela se relajará y las arrugas desaparecerán.



ADVERTENCIA

Este producto se diseñó principalmente para mejorar la apariencia del vehículo y proteger a los ocupantes de las condiciones climáticas comunes. De ninguna manera piense que los componentes de este producto pueden servir como medio de contención para los ocupantes del vehículo o que pueden protegerlos contra lesiones o la muerte en caso de accidente. Este producto no protegerá a los ocupantes contra caídas de objetos. Nunca conduzca este vehículo fuera de las especificaciones del fabricante.

USE LOS CINTURONES DE SEGURIDAD EN TODO MOMENTO

Lea y siga con precisión todas las instrucciones de instalación que se proporcionan para instalar este producto. Si no lo hace, podría producirse un mal ajuste que colocaría a los ocupantes del vehículo en una situación potencialmente peligrosa.



PRECAUCIÓN

Debe usar gafas protectoras en todo momento durante la instalación de este producto.

Conseils pour l'installation

Lire toutes les instructions au complet avant de commencer l'installation de cet assemblage.

Pour un ajustement sans problème :

Afin de faciliter l'installation, ce produit doit être installé à des températures au-dessus de 72 °F (22 °C).

Sous cette température, le tissu peut rétrécir d'un pouce (2,5 cm) ou plus, ce qui rendra l'ajustement sur le véhicule difficile.

Il est normal que le tissu rétrécisse et plisse pendant qu'il est dans la boîte d'expédition. En quelques jours après l'installation, le tissu se détendra et les plis disparaîtront.



AVERTISSEMENT

Ce produit est conçu principalement pour améliorer l'apparence du véhicule et pour protéger les occupants des conditions météorologiques usuelles. Ne jamais se fier aux composants de ce produit pour se protéger de blessures ou de la mort en cas d'accident. Ce produit ne protégera pas les occupants des chutes d'objets. Ne jamais utiliser le véhicule au-delà des caractéristiques techniques indiquées par le fabricant.

PORTER UNE CEINTURE DE SÉCURITÉ EN TOUT TEMPS

Lire et suivre, très fidèlement, toutes les instructions d'installation fournies lors de l'installation de ce produit. Ne pas suivre cette consigne peut causer une installation inadéquate et mettre les occupants du véhicule dans une situation potentiellement dangereuse.



MISE EN GARDE

Des lunettes de sécurité doivent être portées en tout temps lors de l'installation de ce produit.





Installation Instructions Supertop for Trucks

Vehicle Application:
Ford F-150 2015-Current 6.5' Bed
Part Number 77336

Parts List

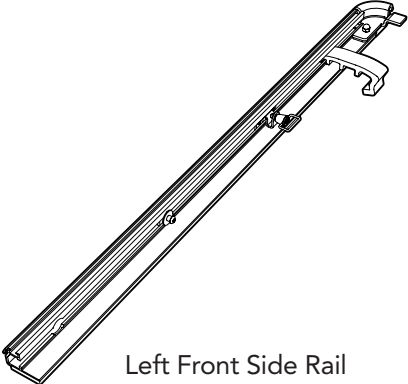
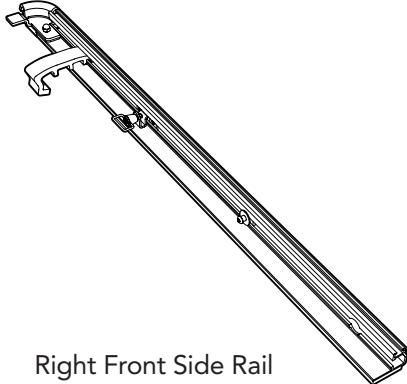
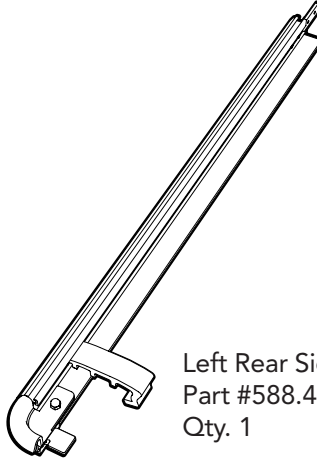
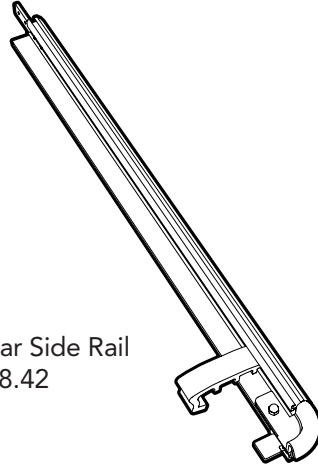
- Required parts for installation

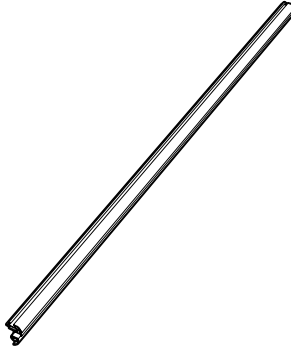
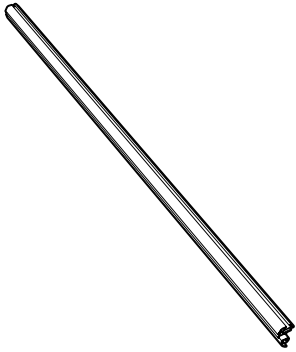
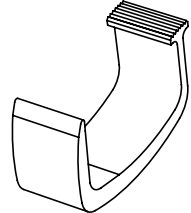
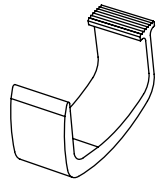
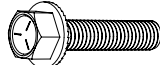
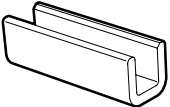
| Sections 1 & 2 | | Side Rails | |
|---|---|---|---|
|  |  |  |  |
| Left Front Side Rail Part #594.29 Qty. 1 | Right Front Side Rail Part #594.30 Qty. 1 | Left Rear Side Rail Part #588.41 Qty. 1 | Right Rear Side Rail Part #588.42 Qty. 1 |

| Sections 2 to 4 | | | | Hardware, Front and Rear Rails | | Pages 6 to 9 of Guide | |
|---|---|--|---|---|--|---|---|
|  |  |  |  |  |  |  |  |
| Front Rail Part #584.94 Qty. 1 | Rear Rail Part #584.95 Qty. 1 | Lower Clamp - Large Part #579.23 Qty. 2 | Lower Clamp - Small Part #595.34 Qty. 2 | Hex Head Bolt Part #578.39 Qty. 4 | Clamp Pad Part #577.39 Qty. 2 | Set Screw Part #573.17 Qty. 4 | Rubber Pad Part #720035 Qty. 4 |







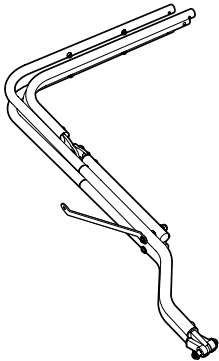
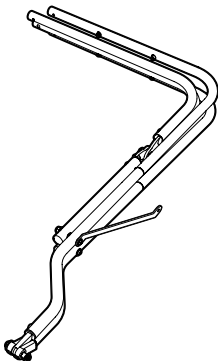
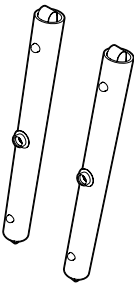
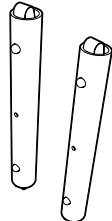
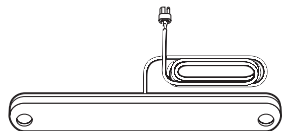

Installation Instructions Supertop for Trucks

Vehicle Application:
Ford F-150 2015-Current 6.5' Bed
Part Number 77336

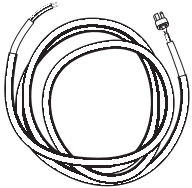
Parts List

- Required parts for installation

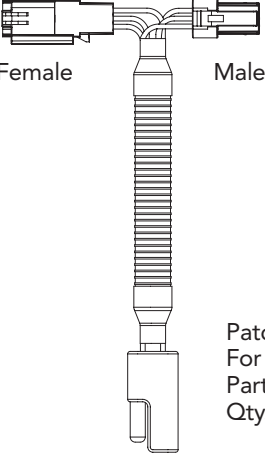
| Sections 5 to 22 | | Bow Stacks, Bow Couplers, Wire Connectors; CHMSL Kit | | | |
|---|--|---|---|---|---|
|  <p>Bow Stack - Driver Side Part #579.39 Qty.1</p> |  <p>Bow Stack - Passenger Side Part #579.38 Qty.1</p> |  <p>Bow Coupler #1 & #4 Bows Part #573.77 Qty. 2</p> |  <p>Bow Coupler #2 & #3 Bows Part #573.79 Qty. 2</p> | <p>Parts Kit #576.71</p>  <p>Center High-Mount Stop Light (CHMSL) Qty. 1</p>  <p>#10-32 Screw Qty. 2</p> |  <p>29' Wire Harness Qty. 1</p>  <p>Flat Washer Qty. 2</p>  <p>#10-32 Nut Qty. 2</p> |

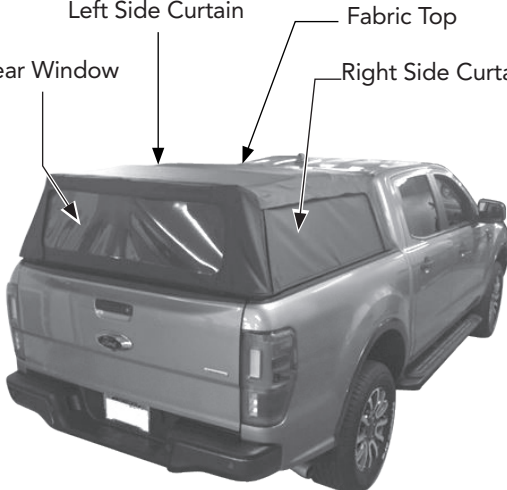
| Sections 17 to 22 | | Patch Loom, Foam Tape, Wire Ties, Top, Window, Side Curtains | |
|--|---|---|--|
|  <p>Female Male</p> <p>Patch Loom For LED Lights Part #593.39 Qty. 1</p> |  <p>Foam Tape Part #595.31 Qty. 1 roll - 24"</p> |  <p>Wire Tie Part #346.58 Qty. 2</p> |  <p>Left Side Curtain Fabric Top Rear Window Right Side Curtain</p> |

Step 1

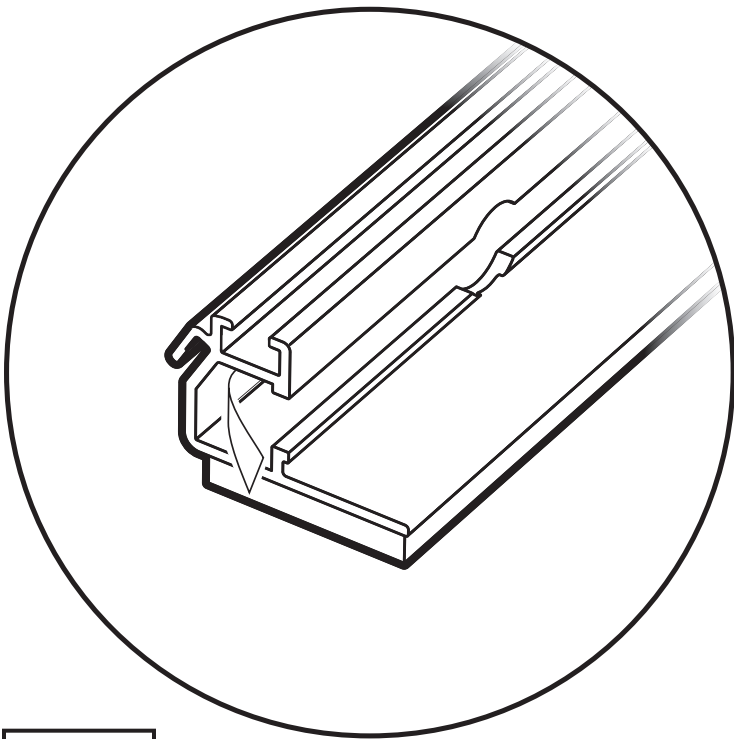

Step 1

Locate the Foam Tape on the Left and Right Side Rails, and remove the paper backing from the foam tape.

Repeat with the both Side Rails.

Hardware

Set Screw
Part #573.17
Qty. 4

Front Side Rail
Part #594.29 - Left (shown)
Part #594.30 - Right
Qty. 1 of each

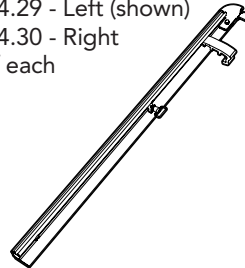

Rear Side Rail
Part #588.41 - Left (shown)
Part #588.42 - Right
Qty. 1 of each

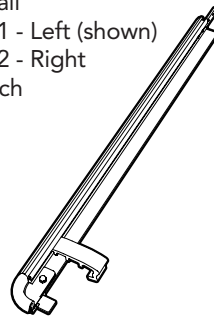

Tools



1/8" Allen Wrench

Step 2

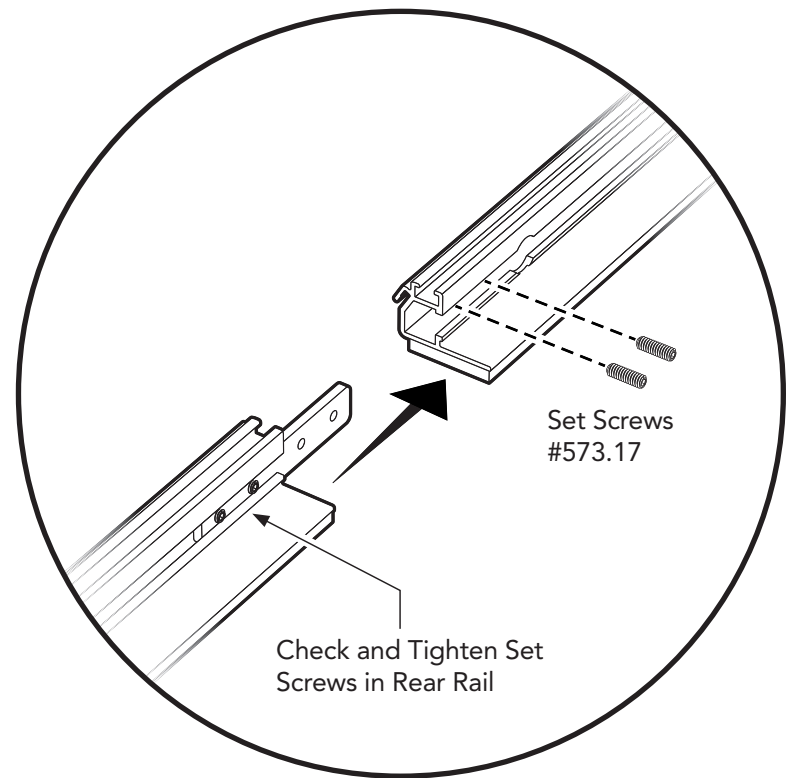

Step 2

Assemble the Left Front Side Rail #594.29 and the Left Rear Side Rail #588.41.

Slide the rails together, and secure using two set screws #573.17.

Check and tighten the two (2) set screws in the rear rail. Tighten set screws to 35 in-lbs torque.

Repeat with the Right Side Rails.

Step 1

Hardware

Step 2

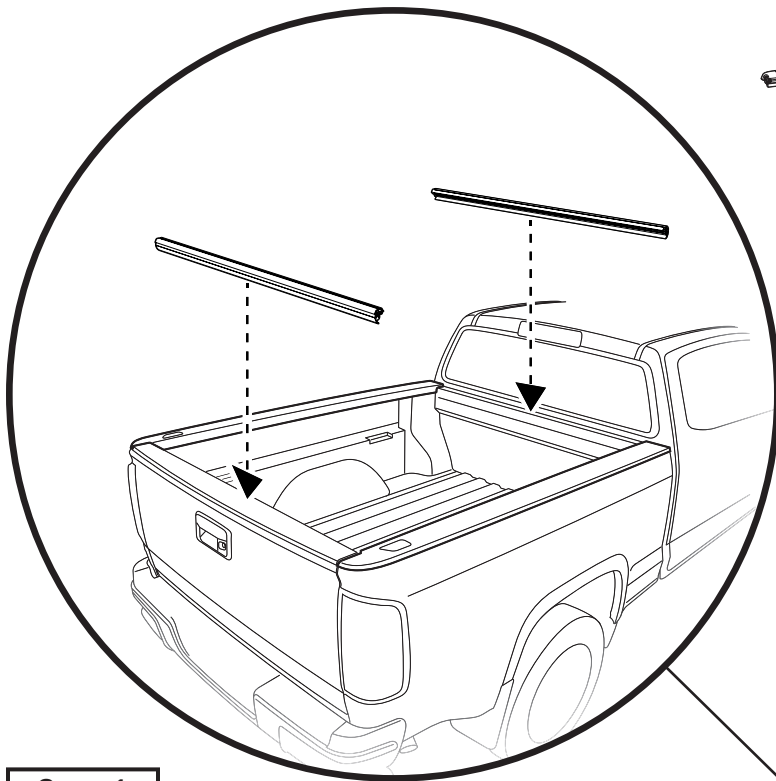

Side Rail Assemblies
Qty. 1 of each



Front Rail
Part #584.94
Qty. 1



Rear Rail
Part #584.95
Qty. 1

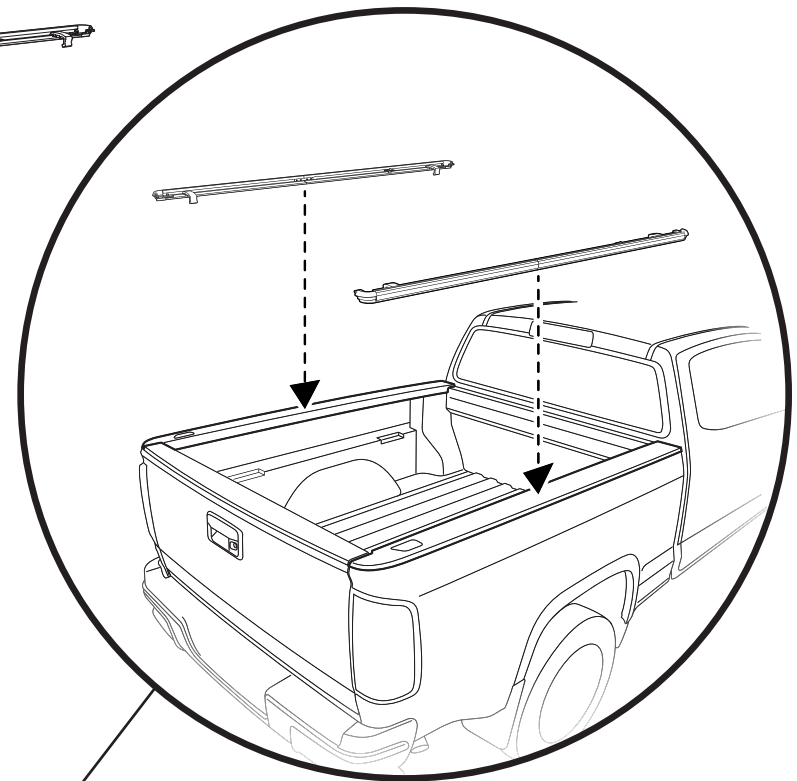

Step 1

Place the Front Rail #584.94 and Rear Rail #584.95 onto the truck bed.

Lay the Rails on top of the truck bed in front, and on top of the plastic bed protector at the rear.

NOTE: The Front Rail is longer than the Rear Rail.

Step 2

Place Side Rail assemblies onto the truck bed. Lay the Rails on top of the plastic bed protectors.

Attach the Side Rails to the Front and Rear Rails.

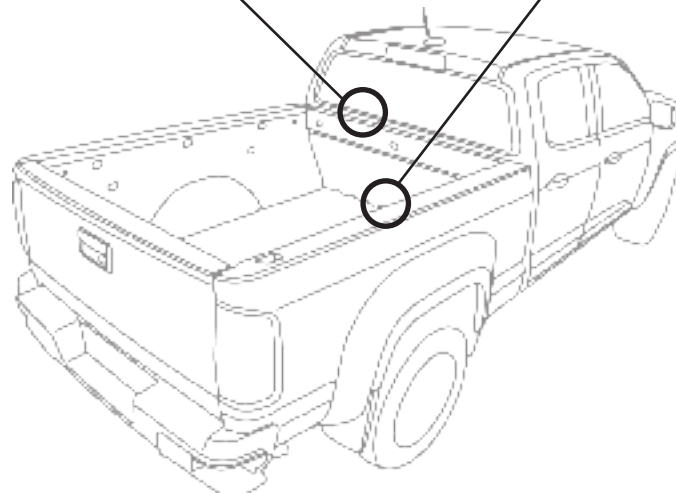

Step 1

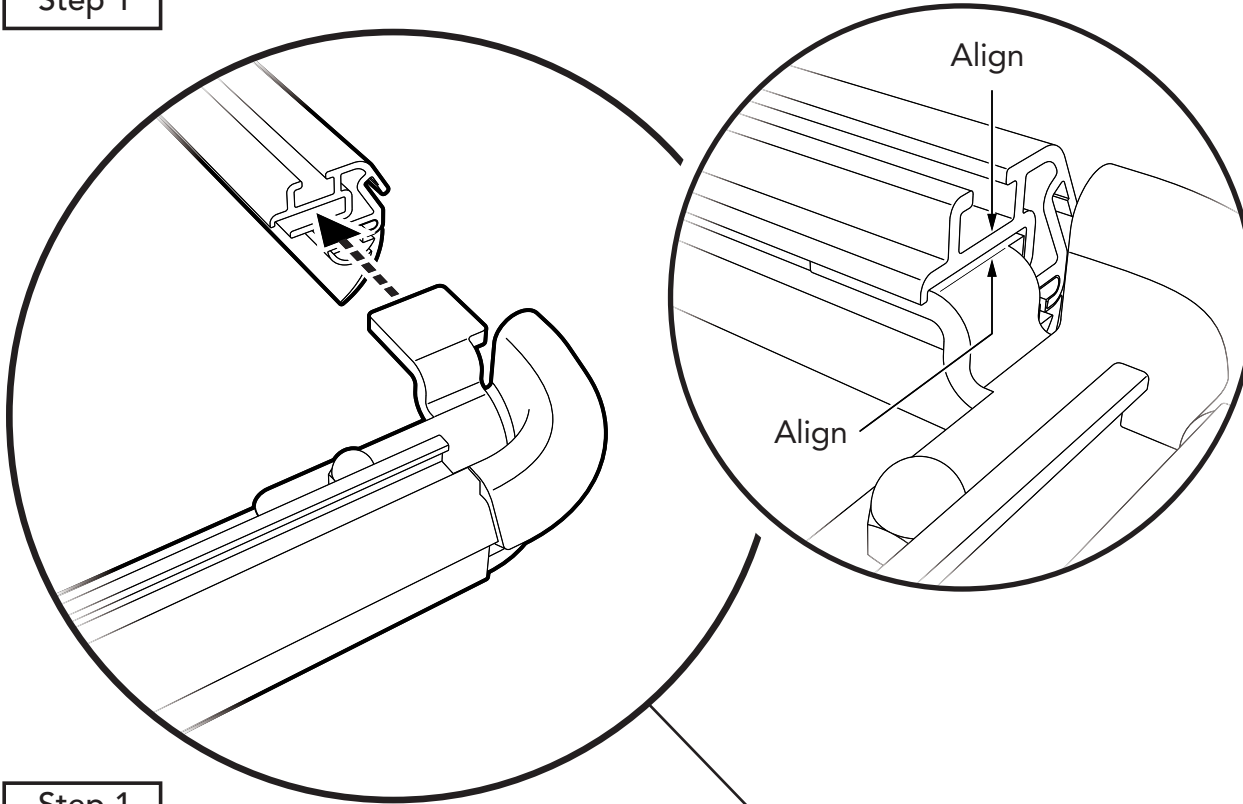

Step 1

Attach the Front and Rear Rails to the Side Rail Assemblies.

Slide the tabs at the front and rear of the Side Rail Assemblies into the slots in the Front and Rear Rails.

Make sure that the ends of the Front Rail and Rear Rail extrusions are aligned with the tongue of the attachment feature, where the tongue bends, and the small corner protrudes.

Step 2

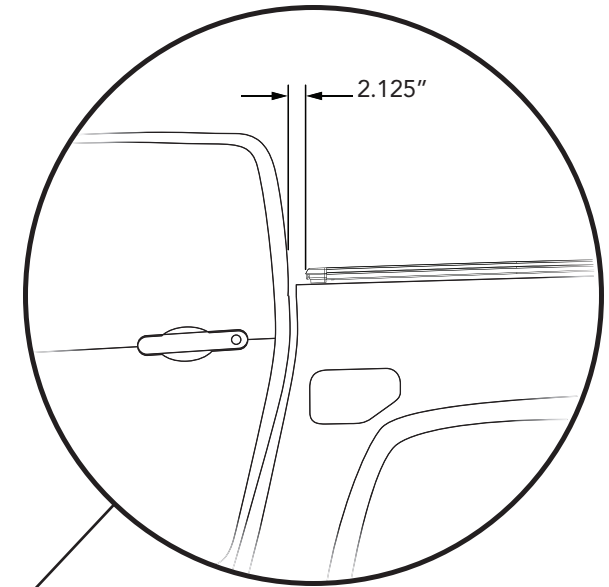

Step 2

Place the outer edge of both side rail corners 2.125" from the back side of the vehicle cab.

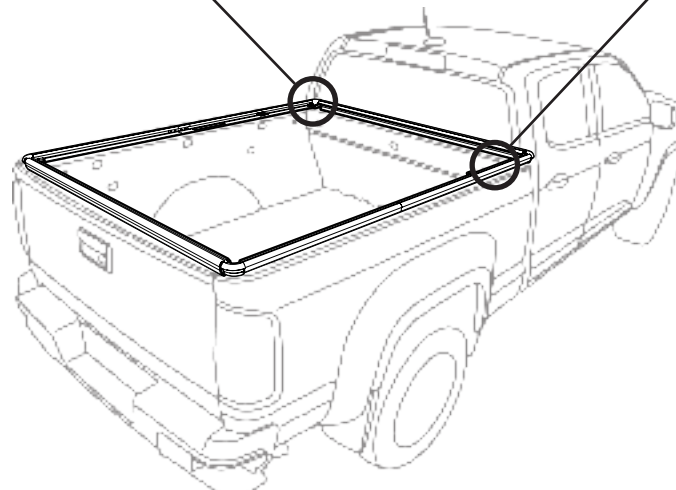

Step 1

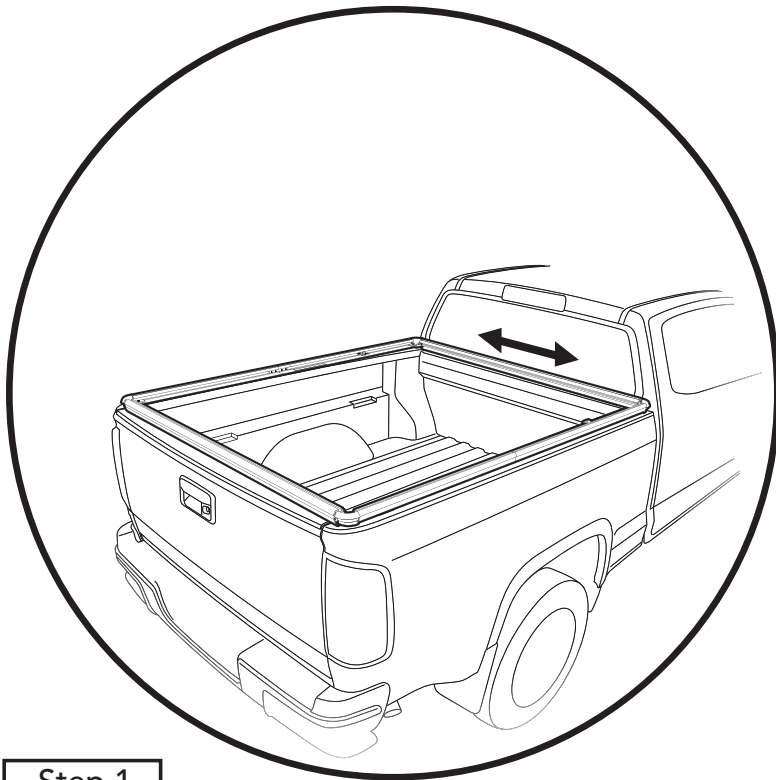

Step 1

Adjust the Side and Front and Rear Rail assembly right-to-left to center it on the bed width.

Hardware

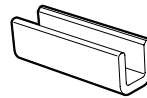

Clamp Pad
Part #577.39
Qty. 2

Step 2

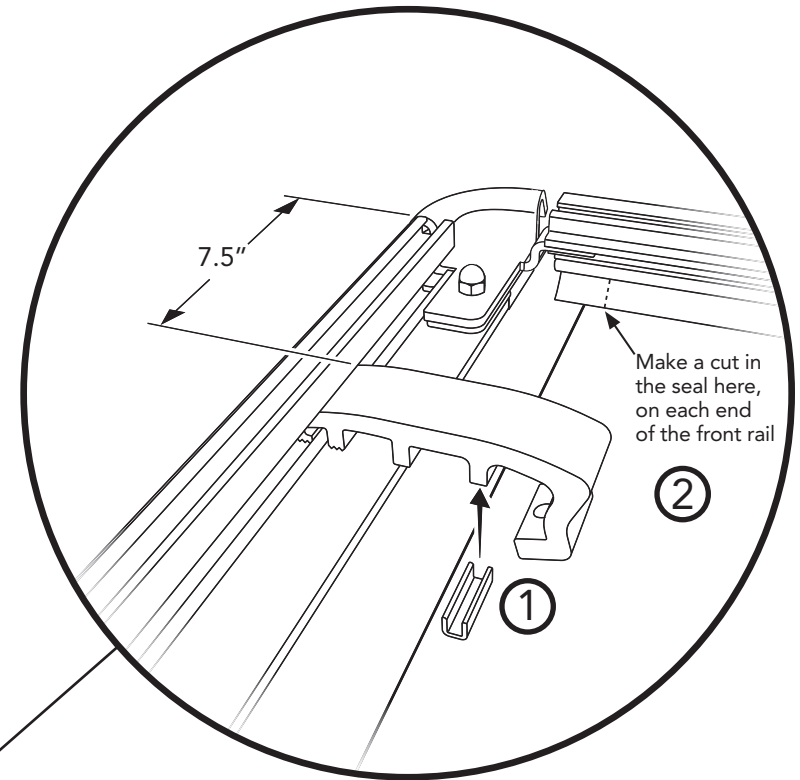

Step 2

① Attach a Clamp Pad #577.39 to each Upper Clamp on the Front Side Rails, on the rib farthest from the side rail.

NOTE: The Clamp Pads must rest on top of the bed rail cap after installation.

The Upper Clamp should be located 7.5" from the end of the Front Side Rail.

② Make two cuts in the seal on the bottom of the front rail, in line with the inner edge of the bed rail cap, so that the seal will lay flat against the bed bulkhead.

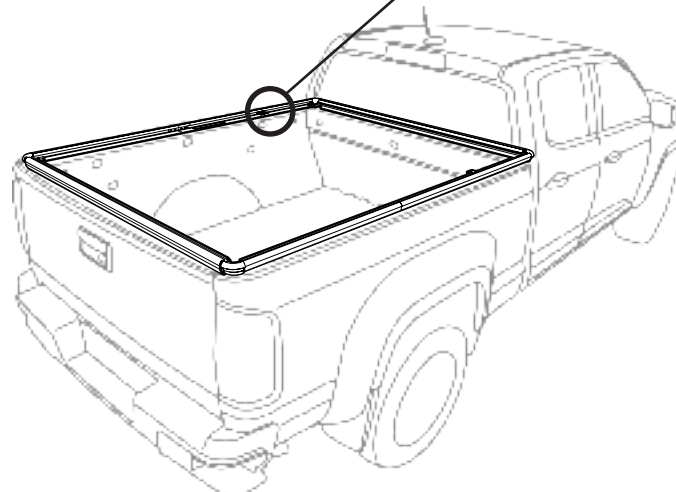

Step 1

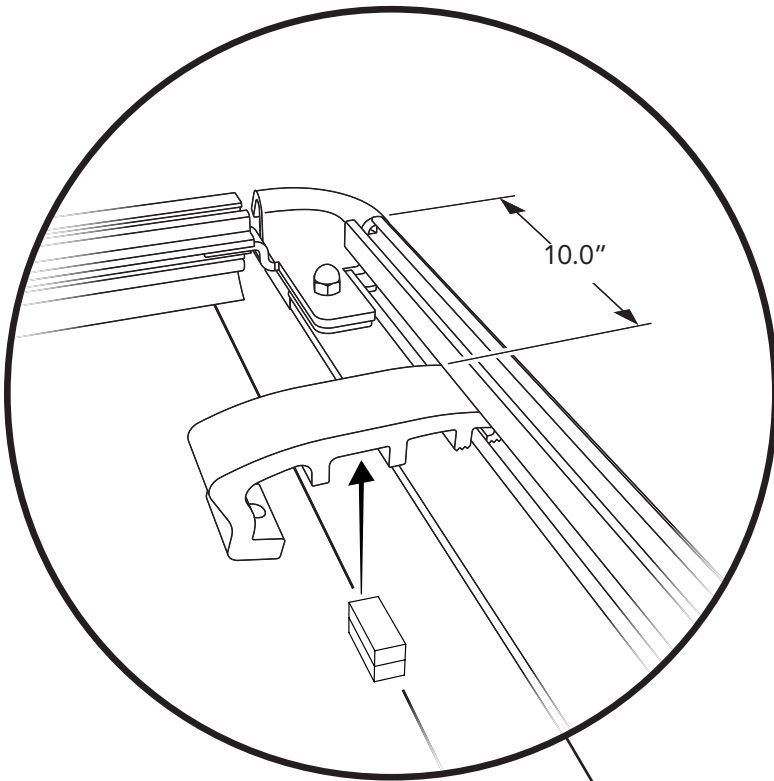

Hardware



Rubber Pad
Part #720035
Qty. 4

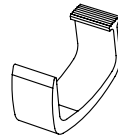

Lower Clamp - Large
Part #579.23
Qty. 2

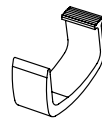

Lower Clamp - Small
Part #595.34
Qty. 2



Hex Head Bolt
Part #578.39
Qty. 4

Tools



Torque Wrench

Step 2

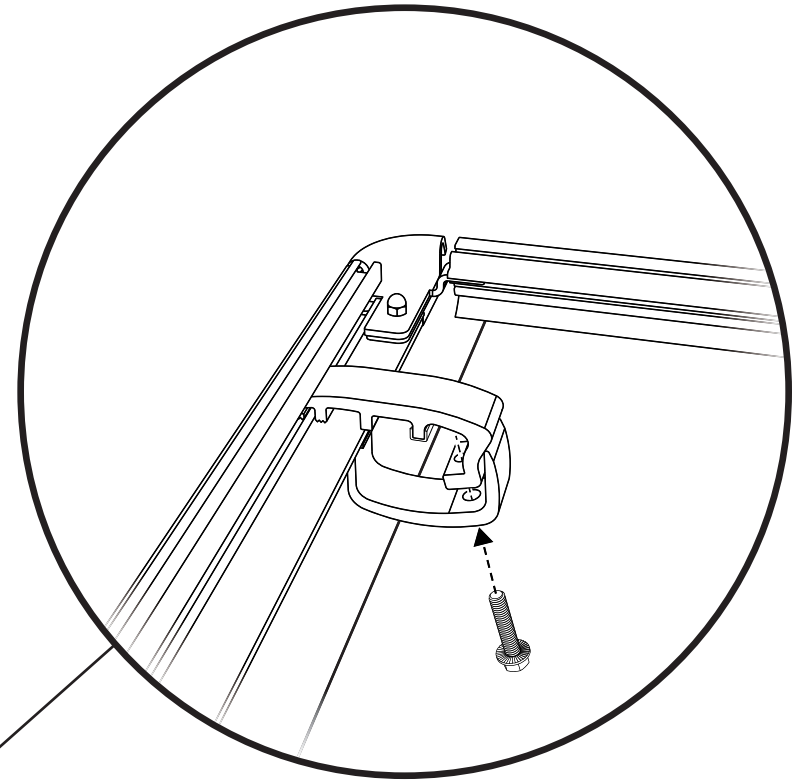

Step 1

Attach two (2) Rubber Pads #720035 together, and stick them to the Rear Rail Clamp, between the rib farthest from the rail, and the next rib.

NOTE : The Rubber Pads must rest on top of the bed rail cap after installation.

The Rear Clamps should be located 10.0" from the end of each Rear Side Rail.

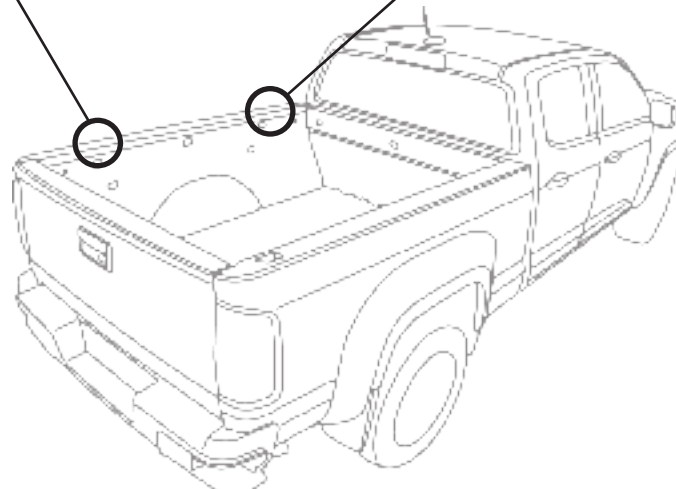

Step 2

Attach Large Lower Clamps #579.23 to the rear pre-assembled Upper Clamps on the Side Rails, using one (1) Hex Head Bolt #578.39 for each clamp.

Attach Small Lower Clamps #595.34 to the front pre-assembled Upper Clamps on the Side Rails, using one (1) Hex Head Bolt #578.39 for each clamp.

Check alignment of the Rail Assembly and tighten all bolts.

Tighten all bolts to 55 in-lbs torque.

Step 1

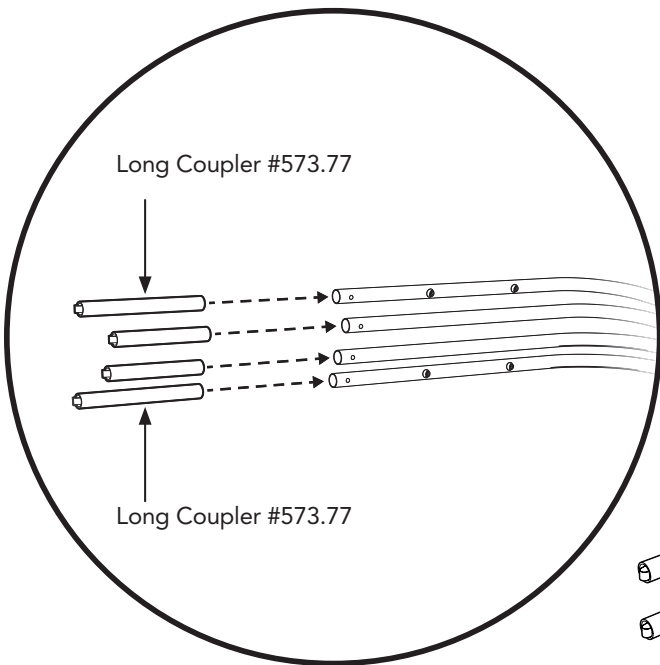

Step 1

Attach Bow Couplers #573.77 and #573.79 to the Passenger Side Bow Stack #579.38.

Insert Long Couplers #573.77 into the outer bows #1 and #4.

Insert Short Couplers #573.79 into the inner bows #2 and #3.

For Easier Installation:

Slide all bows and couplers together before snapping the spring clips into the holes in the bows.

Hardware

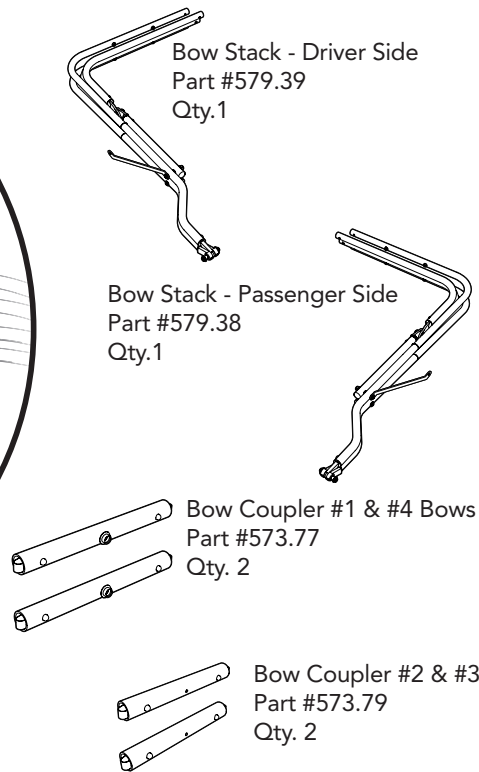

Step 2

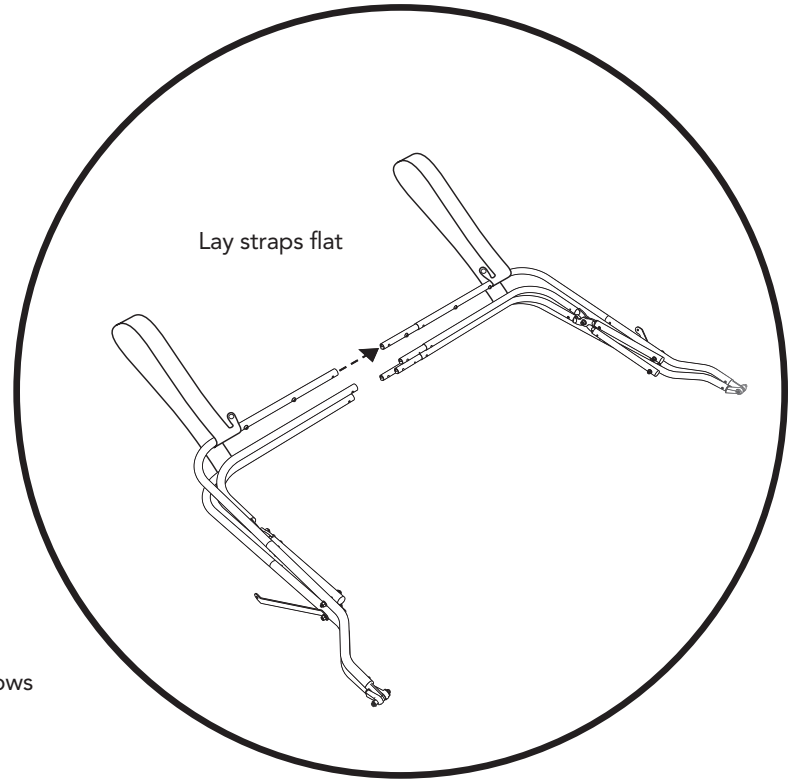

Step 2

Attach Driver Side Bow Stack #579.39 to Passenger Side Bow Stack #579.38.

Bow Stacks attach using the Couplers installed in Step 1.

Slide the Couplers installed in the Passenger Side Bow Stack into the ends of the bows on the Drivers Side Bow Stack.

NOTE: Before attaching couplers to bow stacks, make sure to pull the bond coat straps out and away from the bows, and lay them flat.

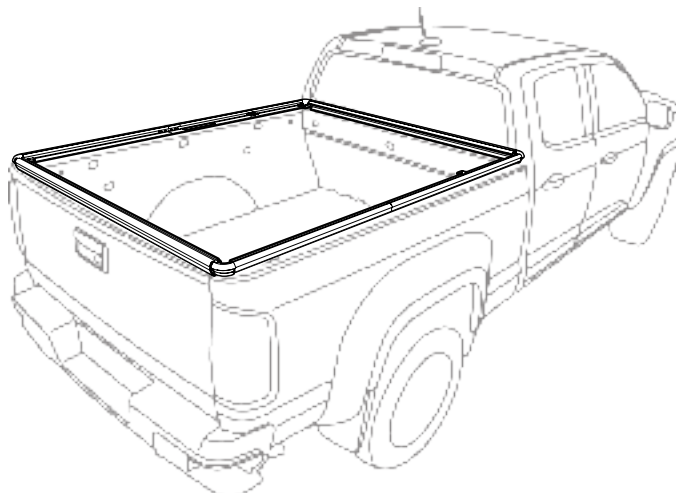

Step 1

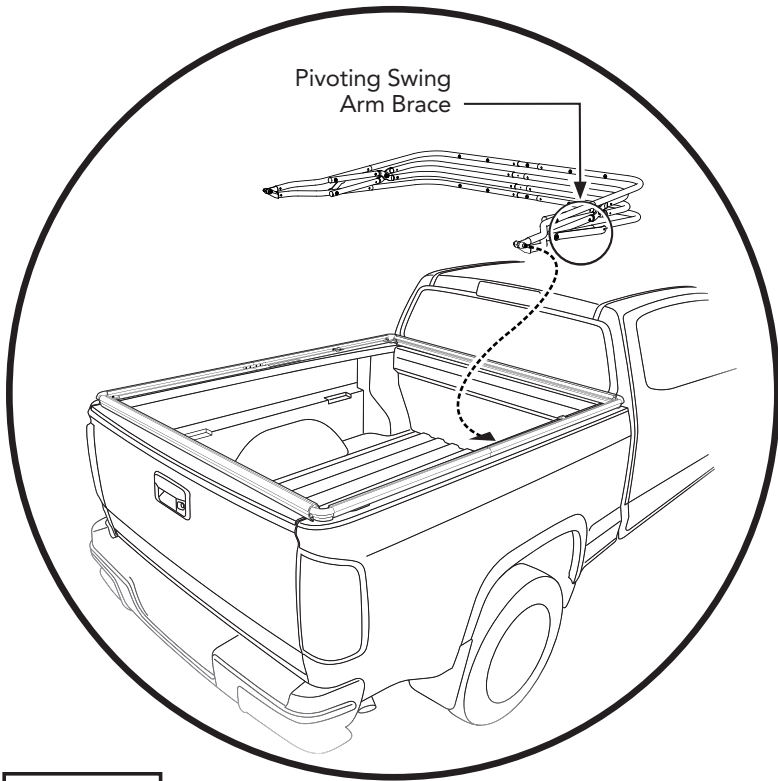

Details

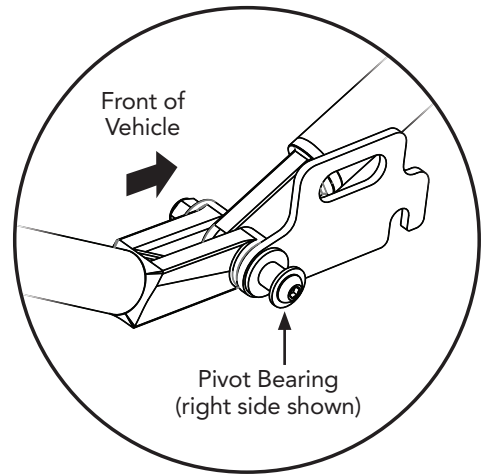

Details

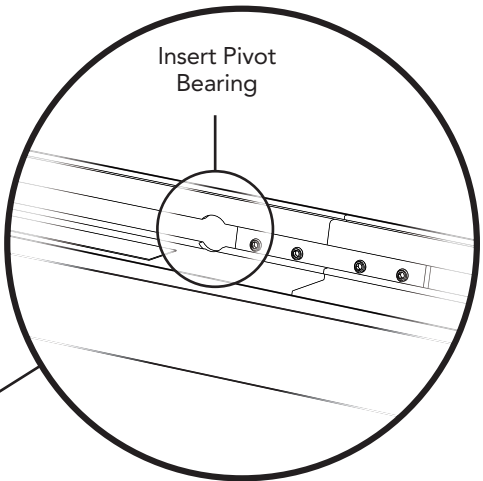

Step 1

NOTE: Two People Are Required for This Portion of the Installation Process.

Place the folded Bow Assembly on the Side Rails. Make sure that the pivot swing arm braces are on the lowest bow.

Insert the Pivot Bearings into the receiving holes in the inside of the side rails

See Details.

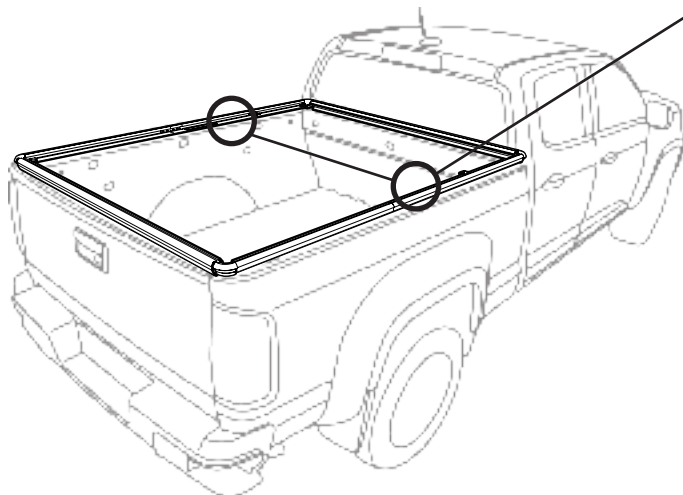

Step 1

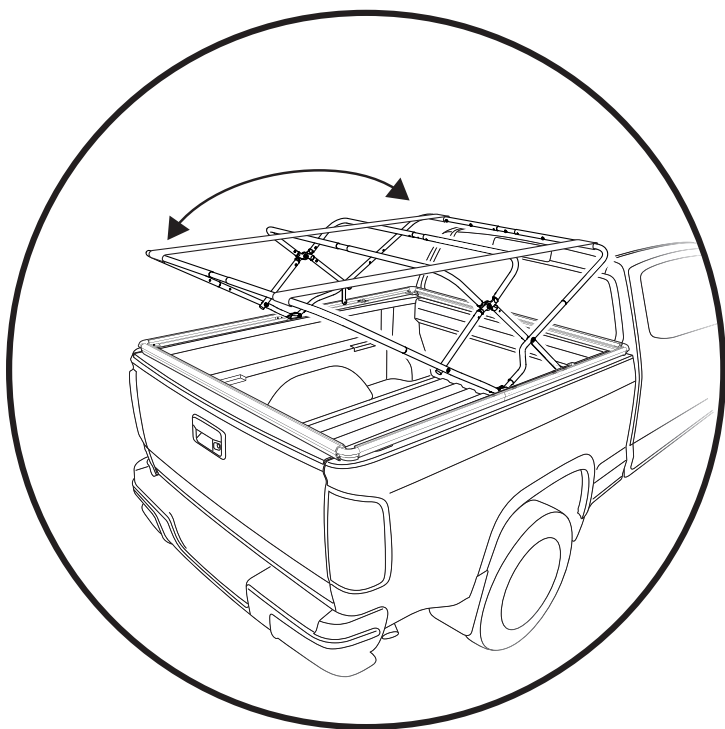

Step 2

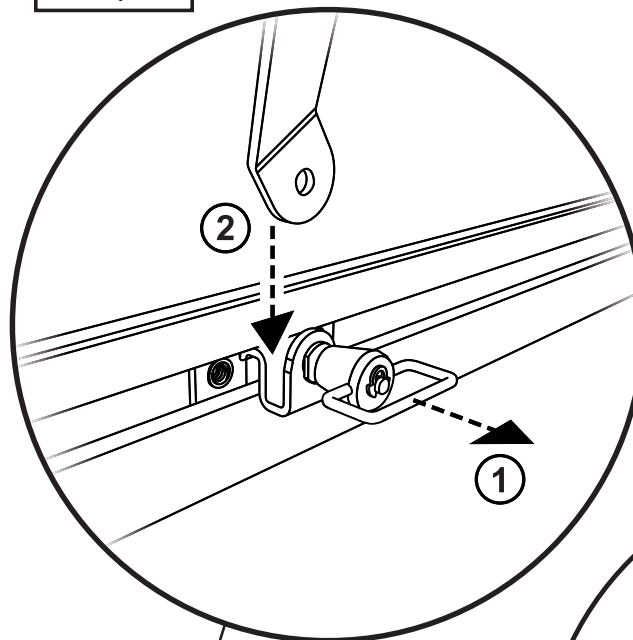

Step 3

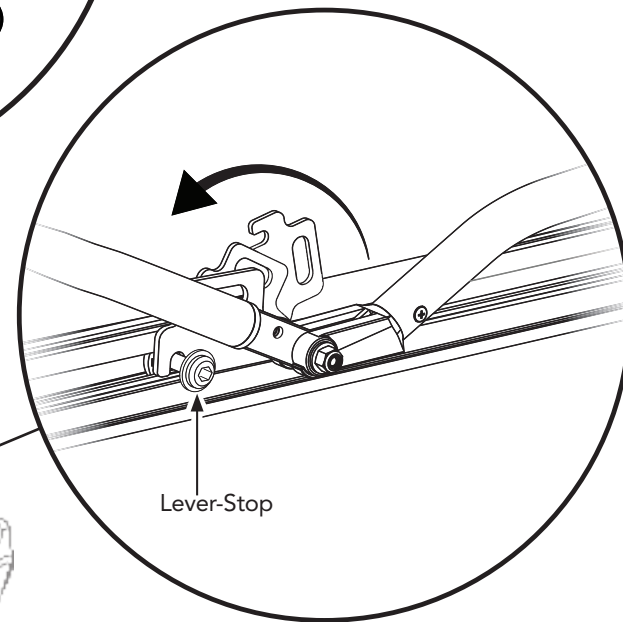

Step 1

Unfold the Bow Assembly.

Step 2

- ① Pull back on the Pivot Knuckle release knob;
- ② Snap the Pivot Arm Brace into place, on both sides of the truck.

Step 3

Engage the Locking Lever on both sides of the truck.

NOTE: The Lever-Stop Assemblies are pre-installed at the factory at 29.0" from the front edge of each Side Rail.

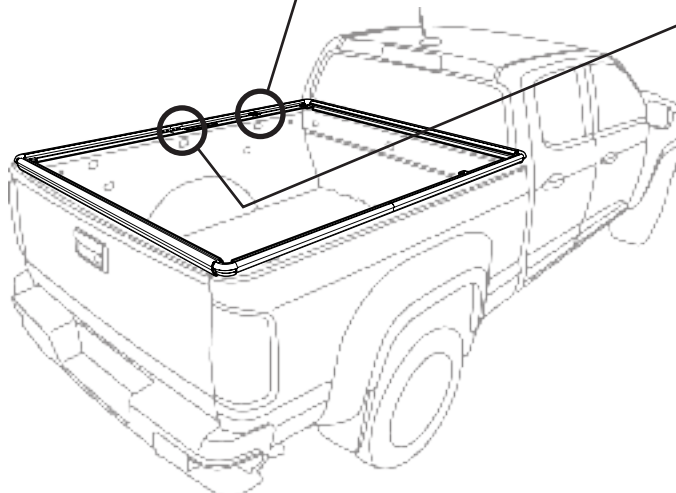

Step 1

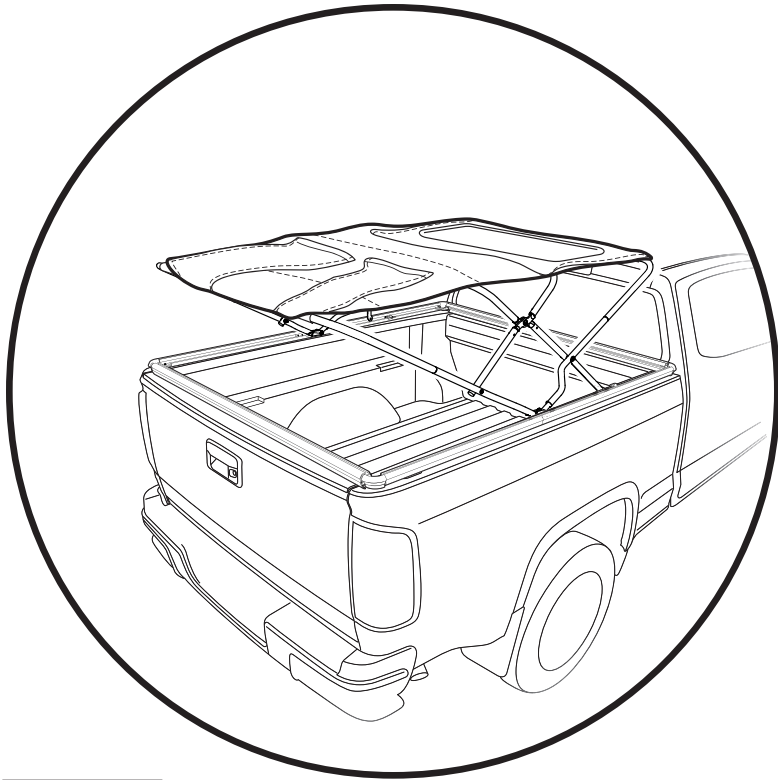

Step 2

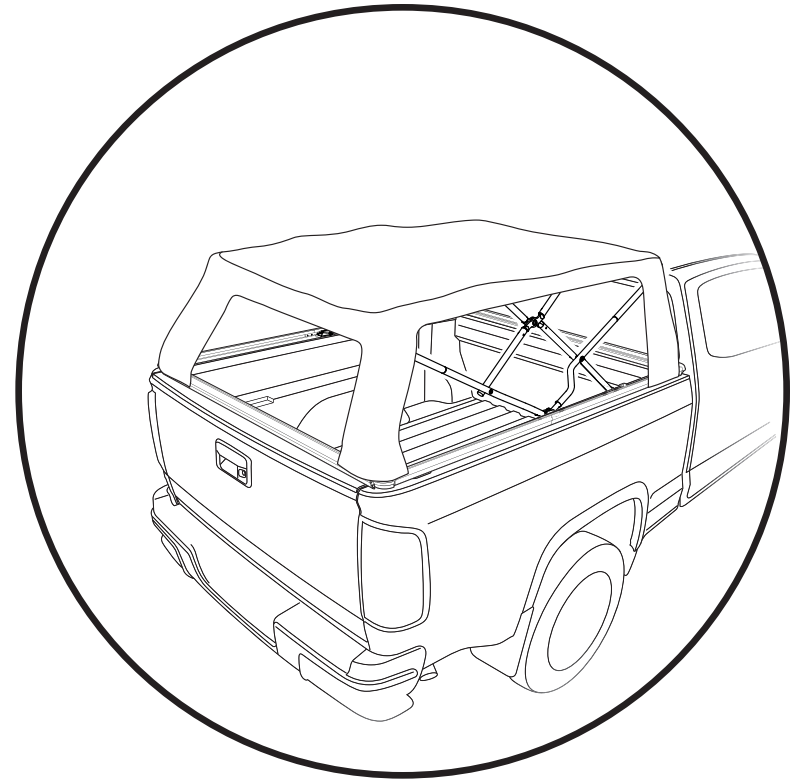

Step 1

Place the folded Soft Top onto the unfolded Bow Assembly.

Step 2

Unfold the front and back of the Top over the #1 and #4 Bows.

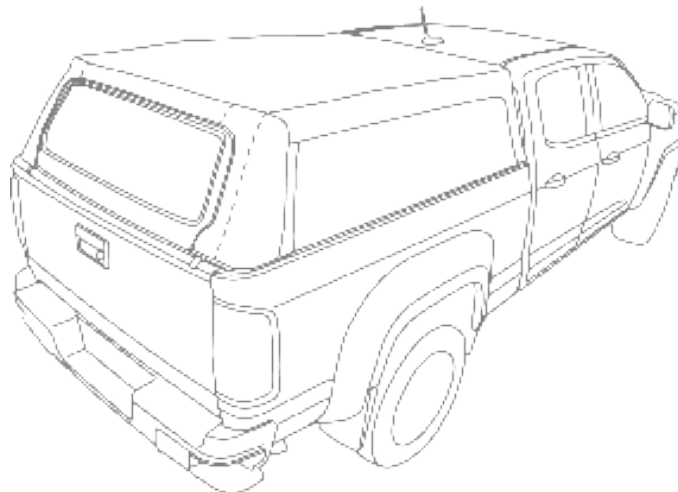

Step 1

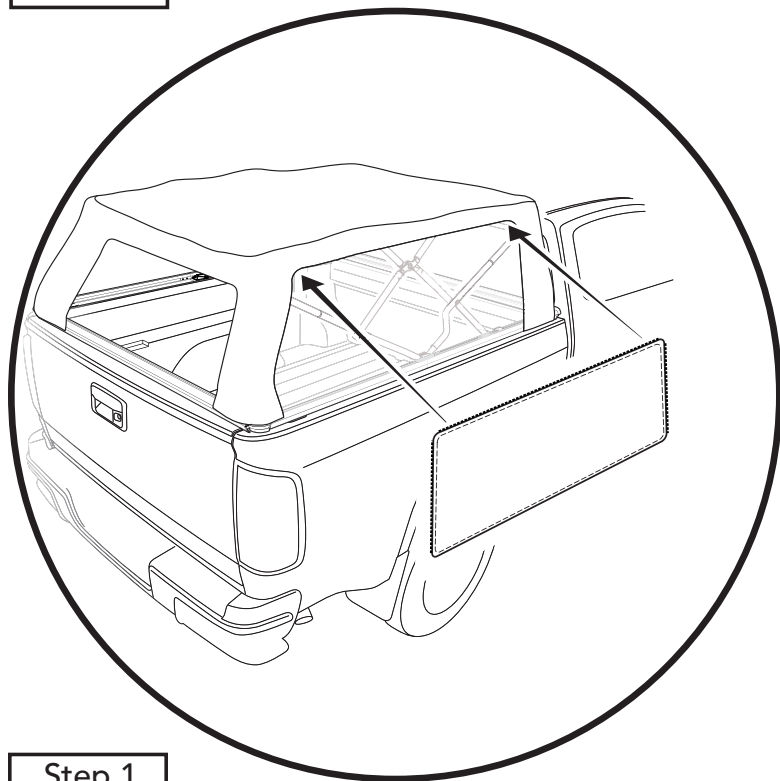

Step 1

For easier access to the zippers, you may want to lift the corners of the top onto the roof fabric.

Zip the Rear Window and Side Curtains into place.

Start with the zipper along the top edge of each panel, and then follow with the side zippers. For ease of installation, start each zipper only about 6".

Once all zippers are started, flip the rear corners into the rail, then zip all zippers completely shut.

Step 2

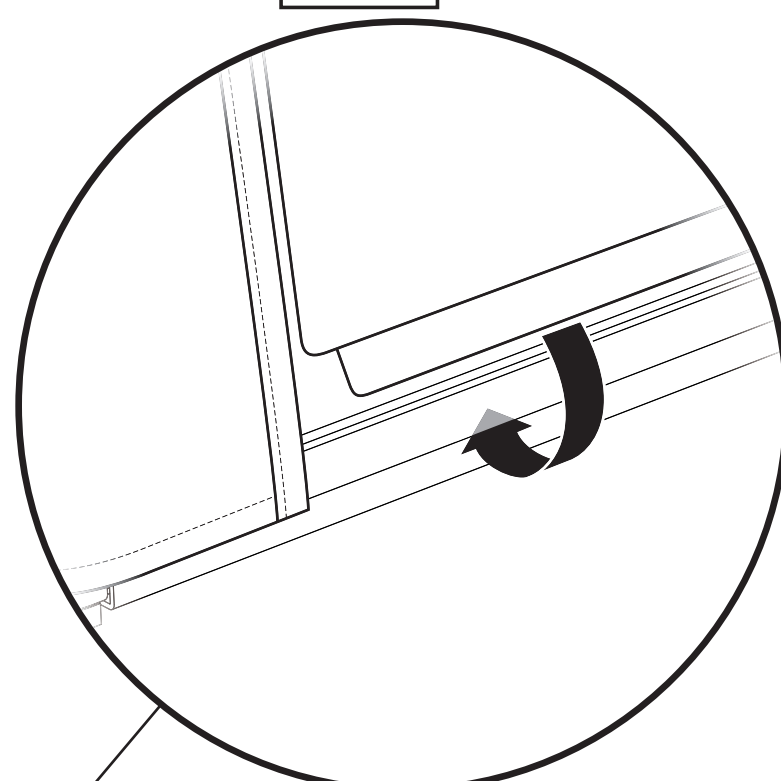

Step 2

Tuck the plastic tab along the bottom edge of each Side Curtain into the slot along the side of each Side Rail.

Tuck the plastic tab along the bottom of the Rear Window into the slot along the side of the Rear Rail.

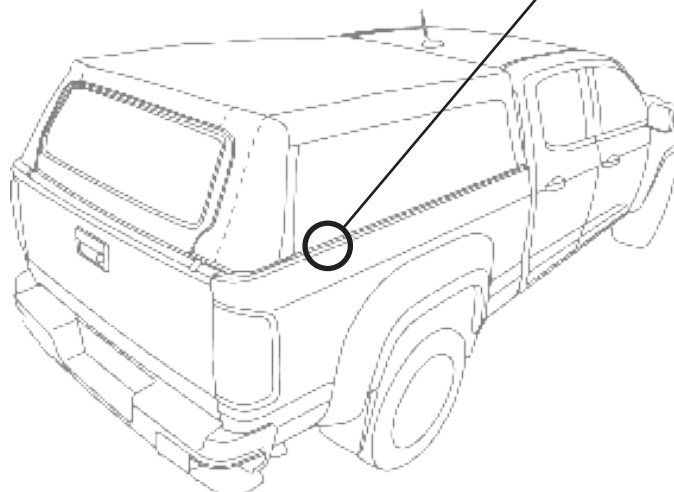

Step 1

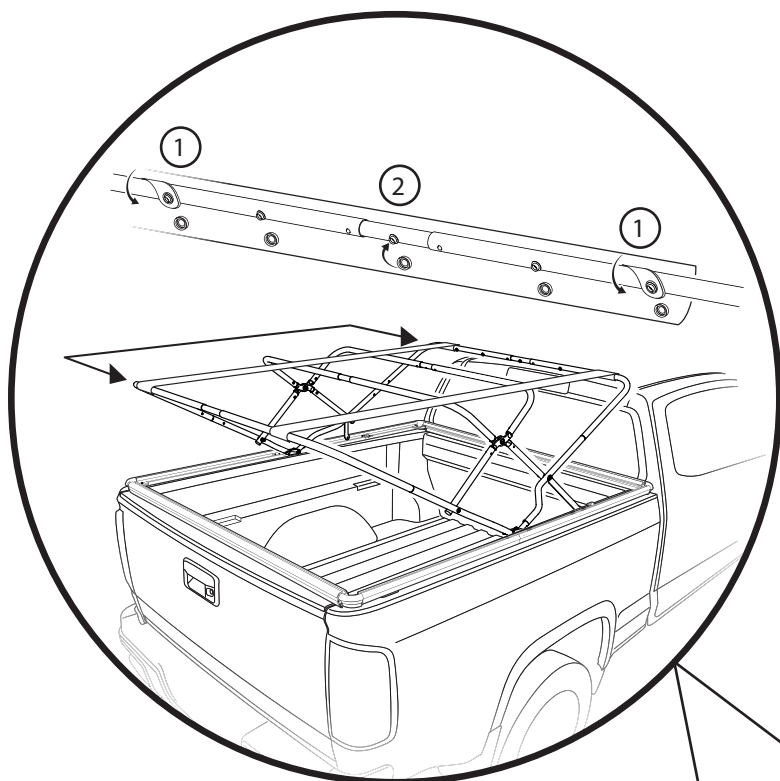

Step 1

From inside the truck bed:

- ① Wrap the small flaps with holes over the outer-most snaps on the #1 bow (Bow closest to the truck cab).
- ② Wrap the fabric flap around the #1 Bow and snap all five snaps to secure the fabric to the Bow.

NOTE: Secure the outer snaps before securing the center snaps.

Repeat for the #4 Bow (Bow closest to the truck tailgate).

Step 2

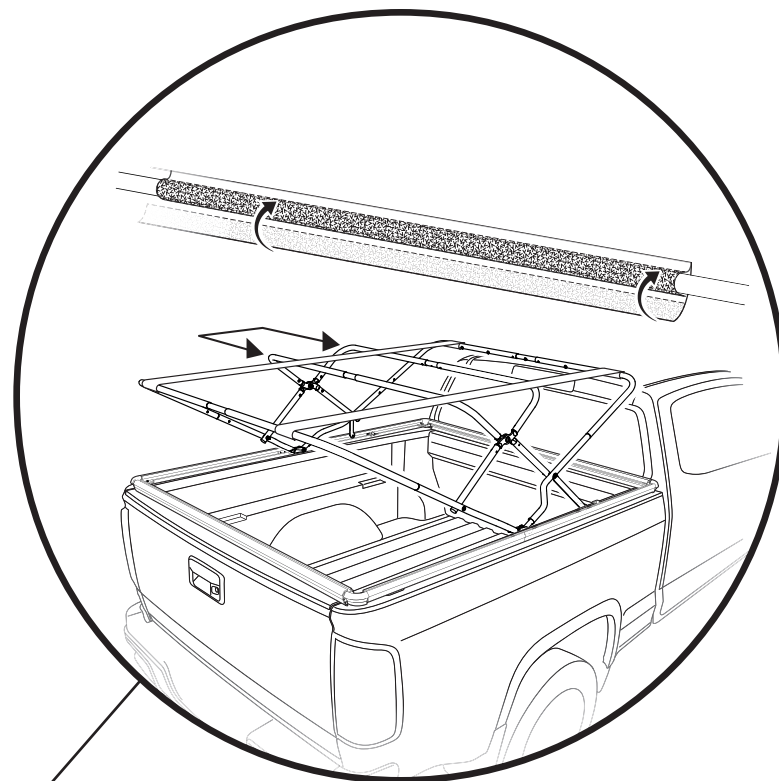

Step 2

From inside the truck bed:

Wrap the fabric flaps with hook-and-loop around the #2 and #3 bows (the two middle bows) to secure the top fabric to these Bows.

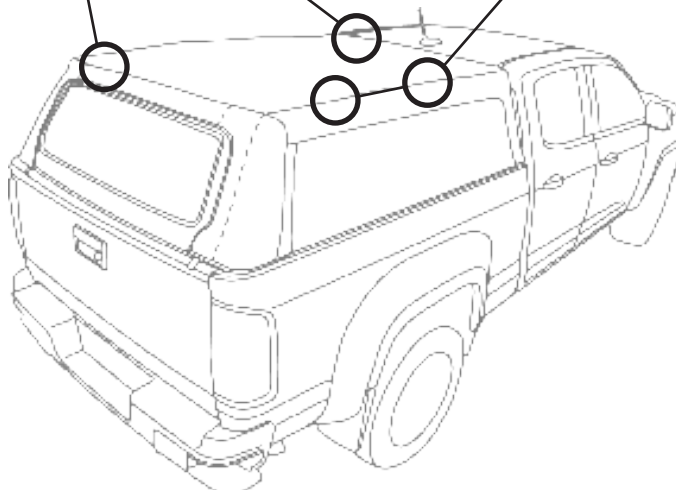

Step 1

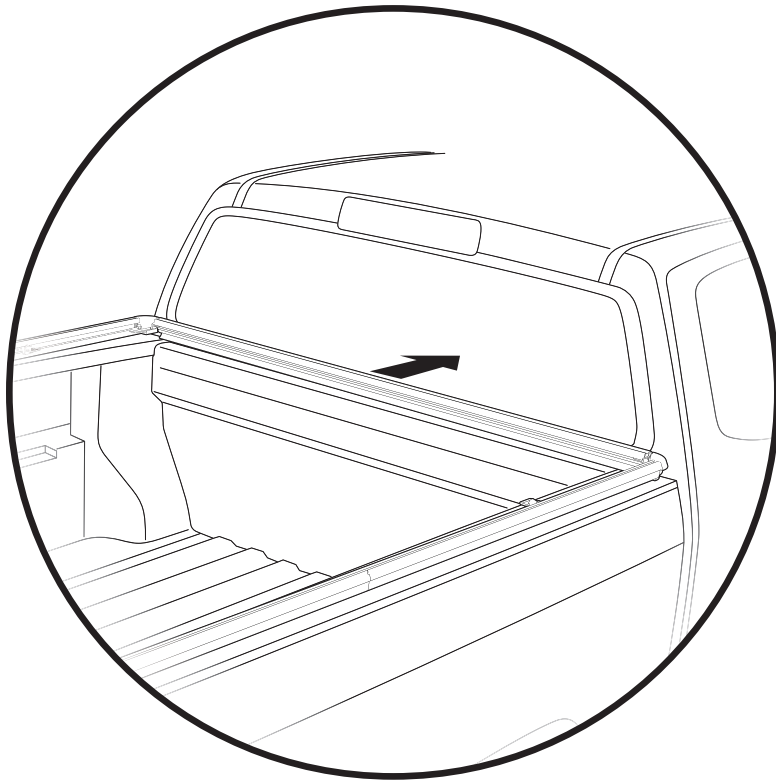

Step 2

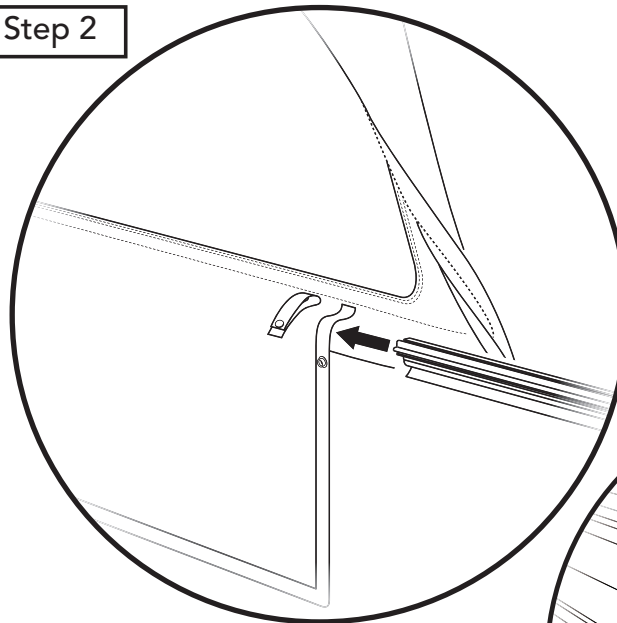

Detail

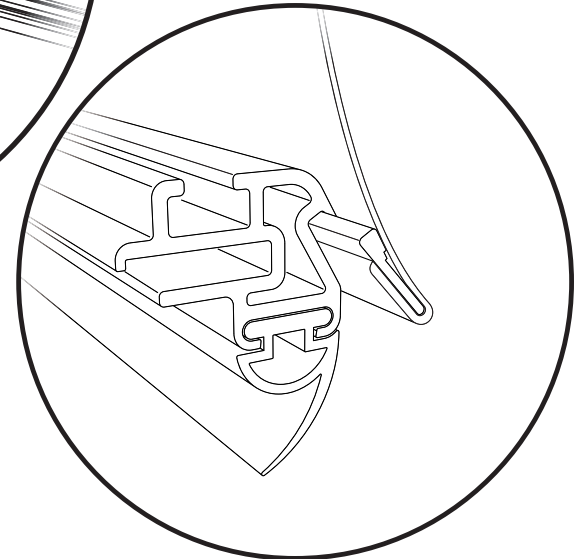

Step 1

Remove the front rail, by sliding it toward the front of the truck bed.

Step 2

Slide the front rail onto the plastic retainer at the bottom of the front window. The rail should go under the large flap.

See Detail.

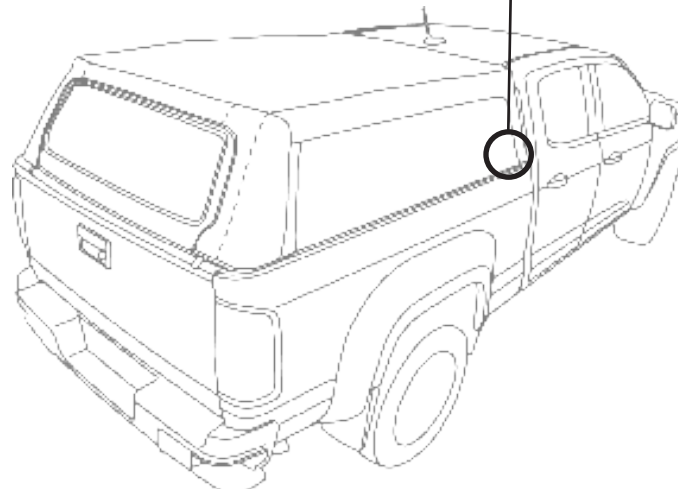

Step 1

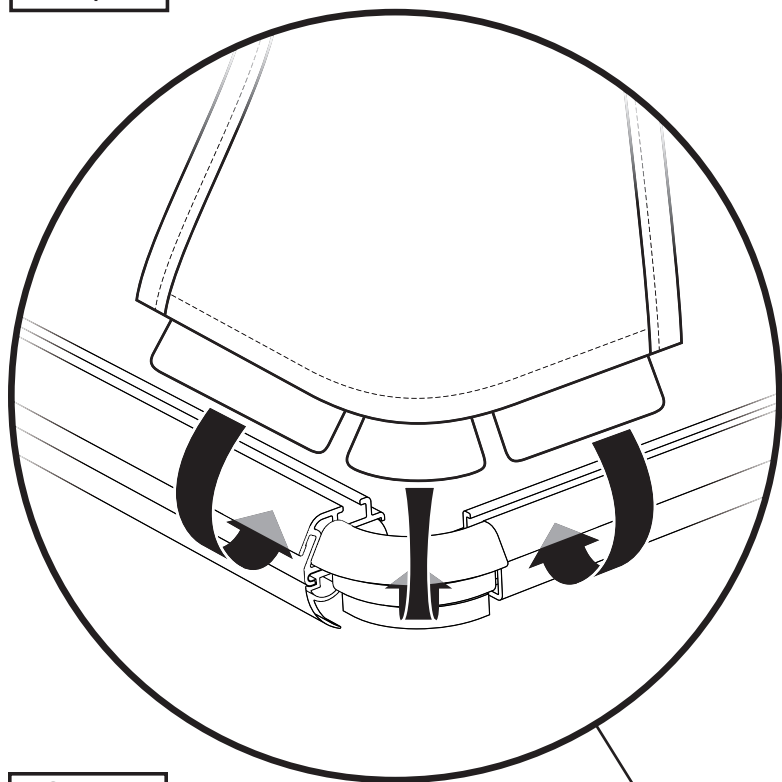

Step 1

Tuck the plastic tabs at the bottom of each corner of the top into the slots in the Side Rails and Front and Rear Rails.

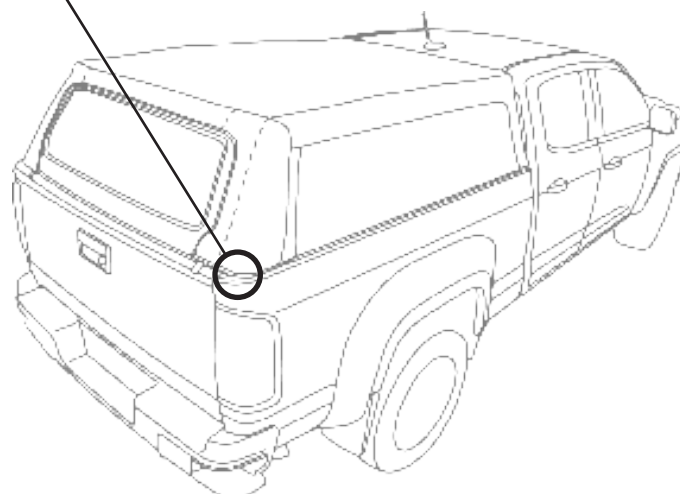

Step 1

Hardware Kit #576.71

Step 2

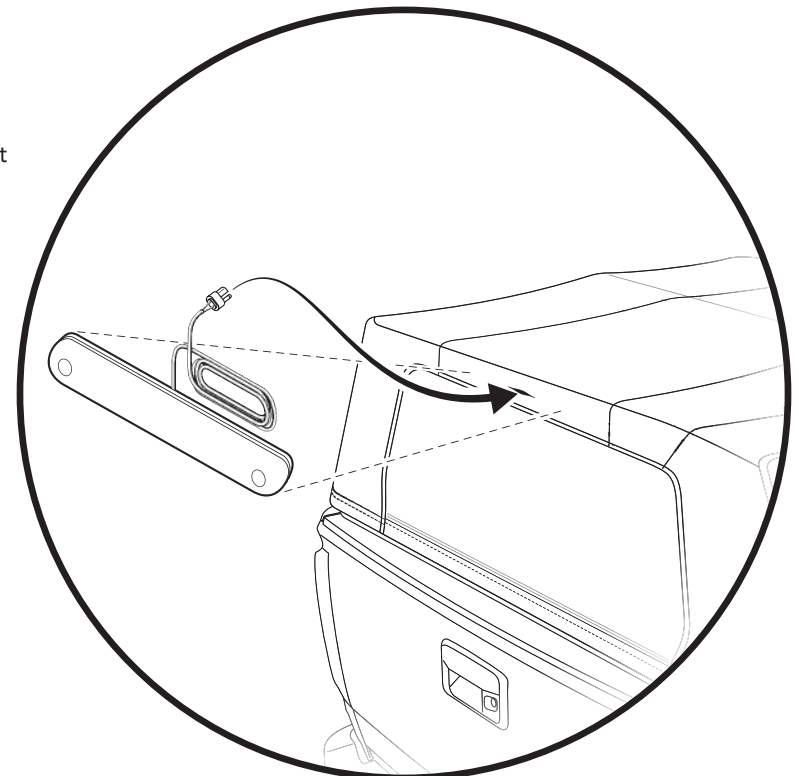
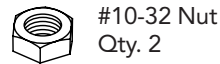
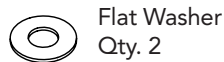
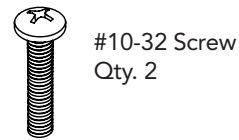
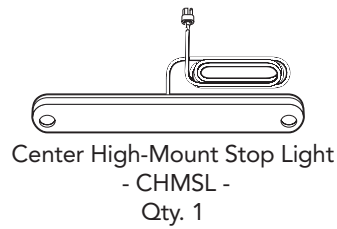
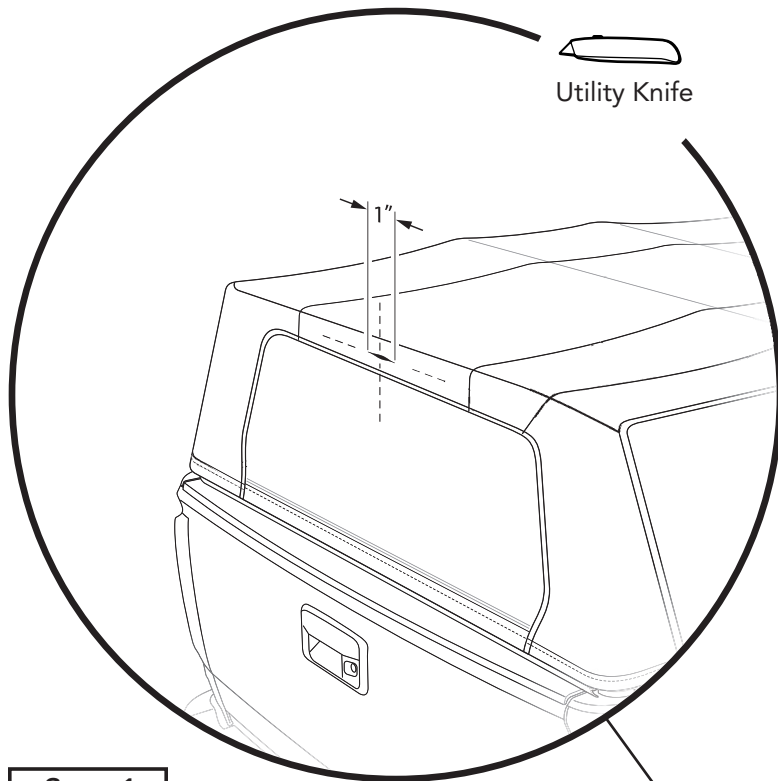

Step 1

Using a utility knife, cut a 1" wide slit through both layers of fabric in the area above the middle of the rear window, and in the vertical center of the fabric.

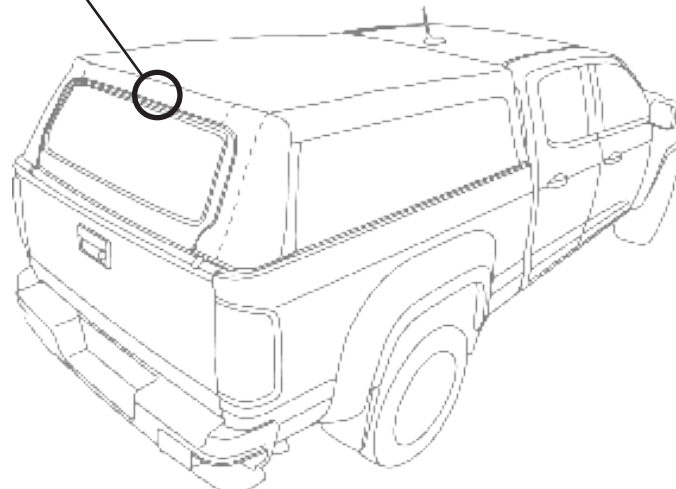

Step 2

Feed the connector end of the CHMSL wire harness through the slit in the top fabric, and pull the wire all the way through both layers of fabric.

Make sure that the light is centered, straight and level, and attach the Stop Light to the top fabric using two (2) 10-32 Screws, two (2) Flat Washers and two (2) 10-32 Nuts. The Nuts and Flat Washers go on the inside of the fabric.

You'll need to pierce the fabric for the screws to go through.

Step 1

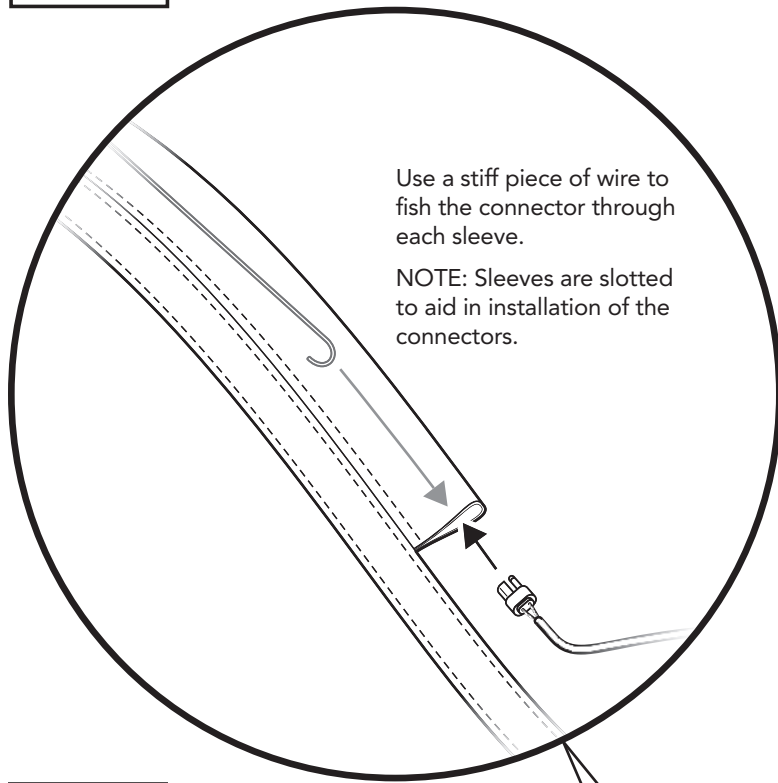

Detail

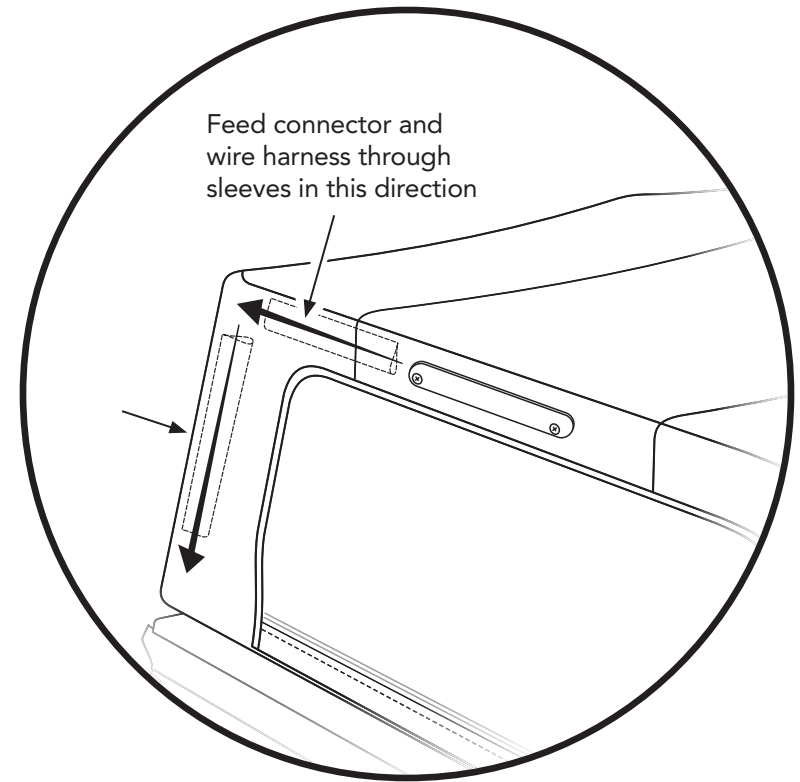

Step 1

Feed the connector and wire harness through the fabric sleeves on the inside of the top.

The sleeves run across the top and down the rear corner of the top fabric.

Use a stiff piece of wire or a rod to fish the connector through the sleeves.

See Detail.

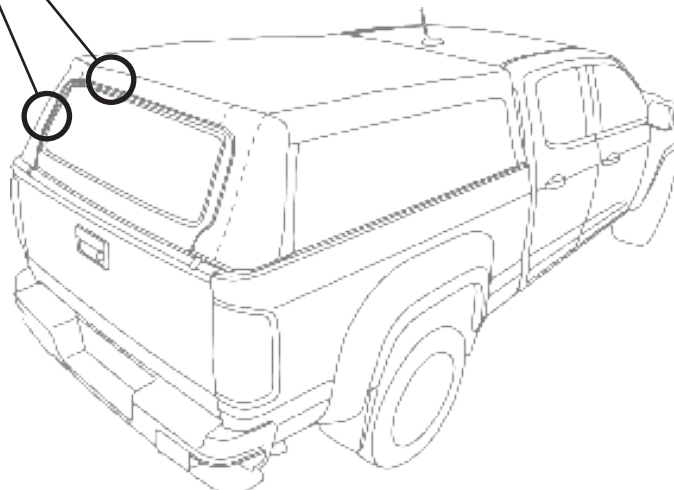

Step 1

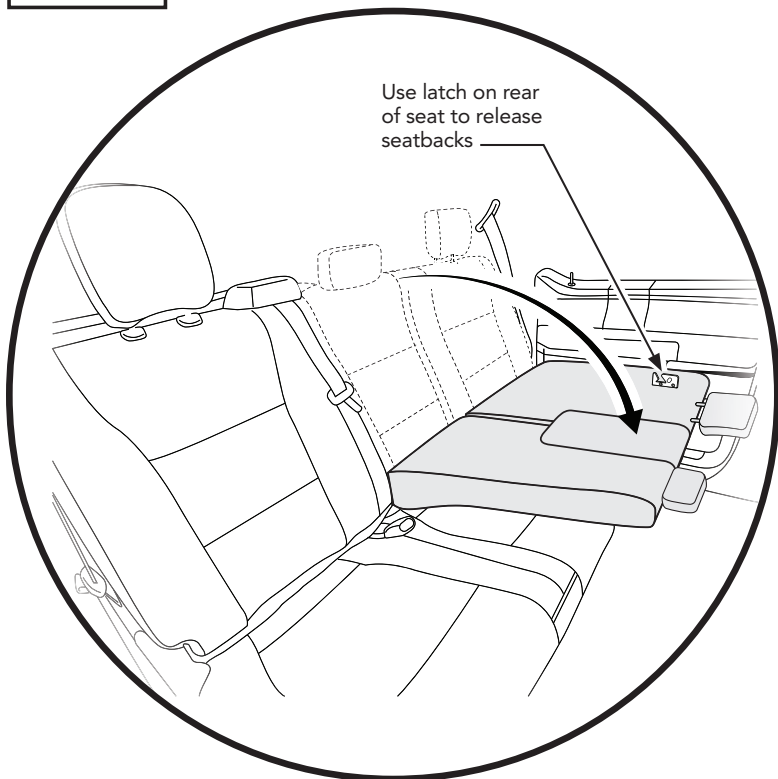

Tools



T20 Torx Driver

Step 2

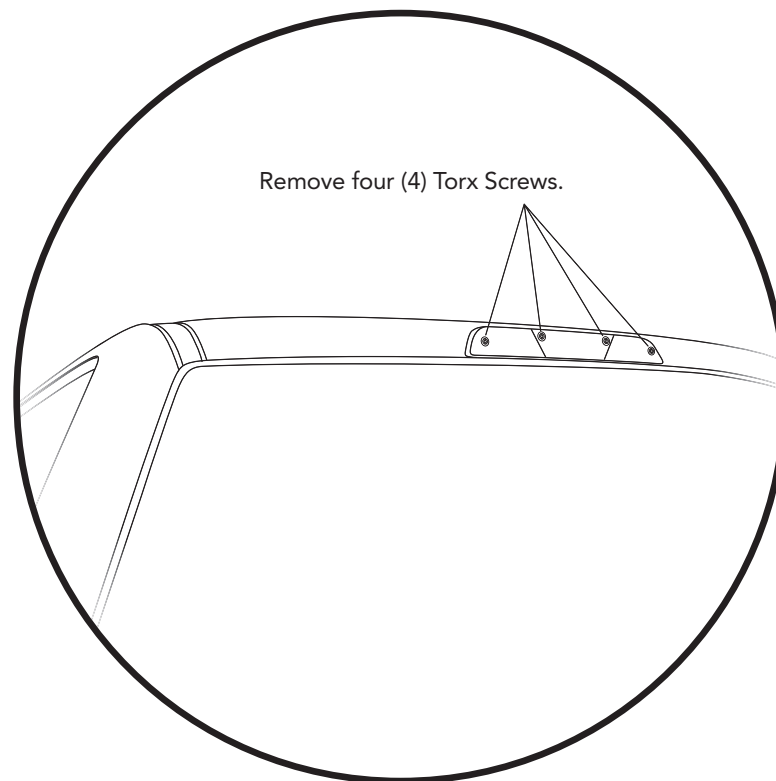

Step 1

Use the latch on the rear of the driver side rear seatback to release the driver side and middle seatbacks, and flip both seatbacks forward.

Step 2

Use a T20 Torx Driver to remove the 4 screws that attach the Center High-Mounted Stop Light to the vehicle cab, and remove the CHMSL.

The light housing will remain attached to the wire harness - do not cut any wires at this time.

Step 1

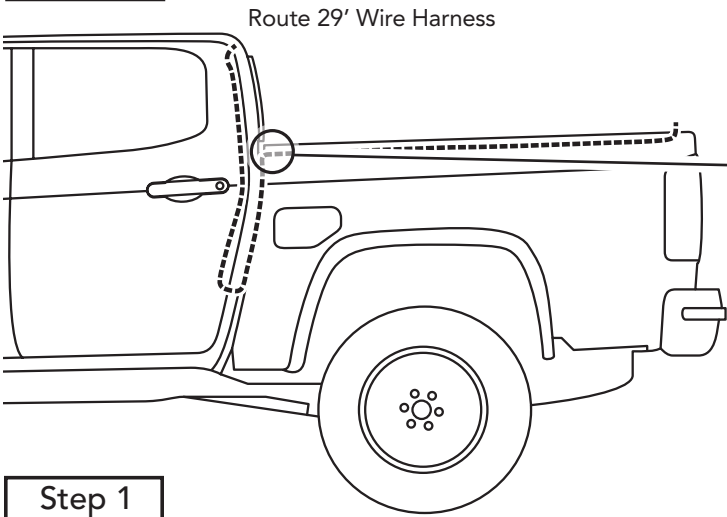

Detail A

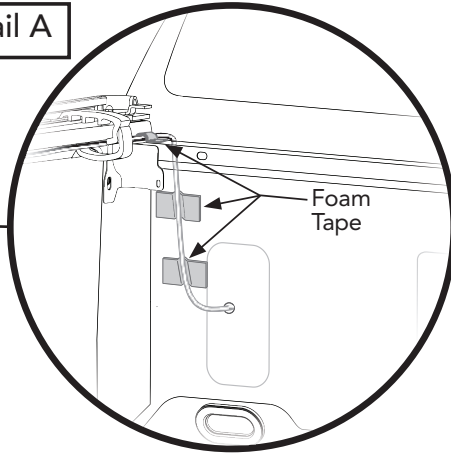

Detail B

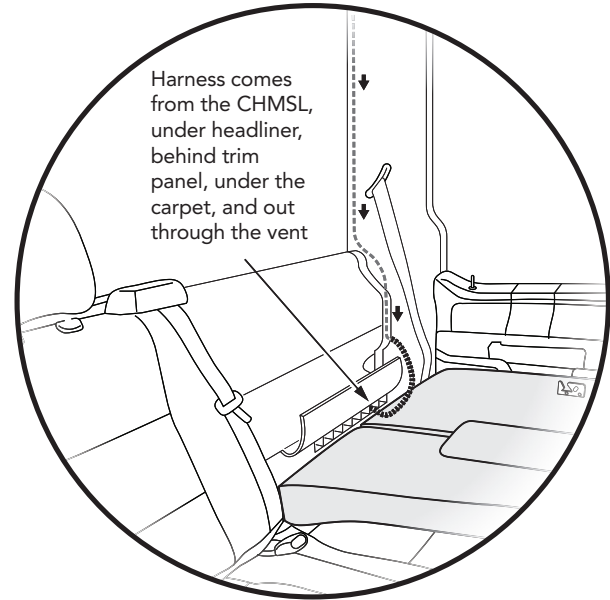

Step 1

Route the 29' Wire Harness from the interior side of the CHMSL, above the headliner, down the rear driver side pillar, under the carpet, through the cab vent, into the vehicle bed, and along the top of the bed, underneath the bed rail cap. See Detail B.

NOTE: Be sure the wire harness is secured between the vehicle cab and bed. Cut three 2" pieces of the Foam Tape #595.31 and use the tape to fasten the wire to the back side of the vehicle bed, and to the top of the bed as shown in Detail A.

Tools



Utility Knife

Hardware

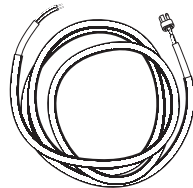

29' Wire Harness Qty. 1



Foam Tape Part #595.31 2" Pieces

WARNING

Wire Harness must be routed clear of all airbags.

Step 1

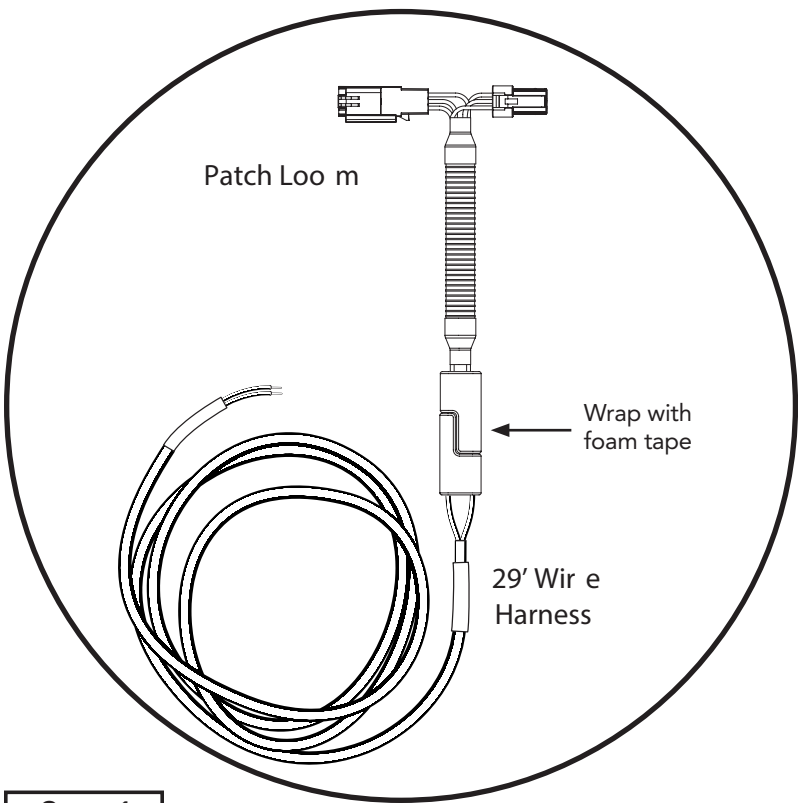

Hardware

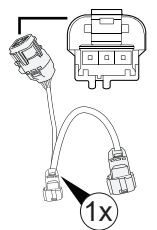

Patch Loom



Foam Tape
Part #595.31
2" Pieces



Wire Tie
Part #346.58
Qty. 2

Step 1

From outside the vehicle, connect the Vehicle Patch Loom #593.39 to the 29' Wire Harness.

On the 29' connection to Patch loom, use 2" pieces of foam tape #595.31 and wrap the foam tape around the connection to secure the connection together.

NOTE: There will be leftover CHMSL wire after running wire to the rear of the vehicle bed. On the inside of the cab, roll the wire bundle up and use wire tie #346.58 to secure it.

The wire bundle can be tucked behind the carpet or trim behind the rear seats.

Step 2

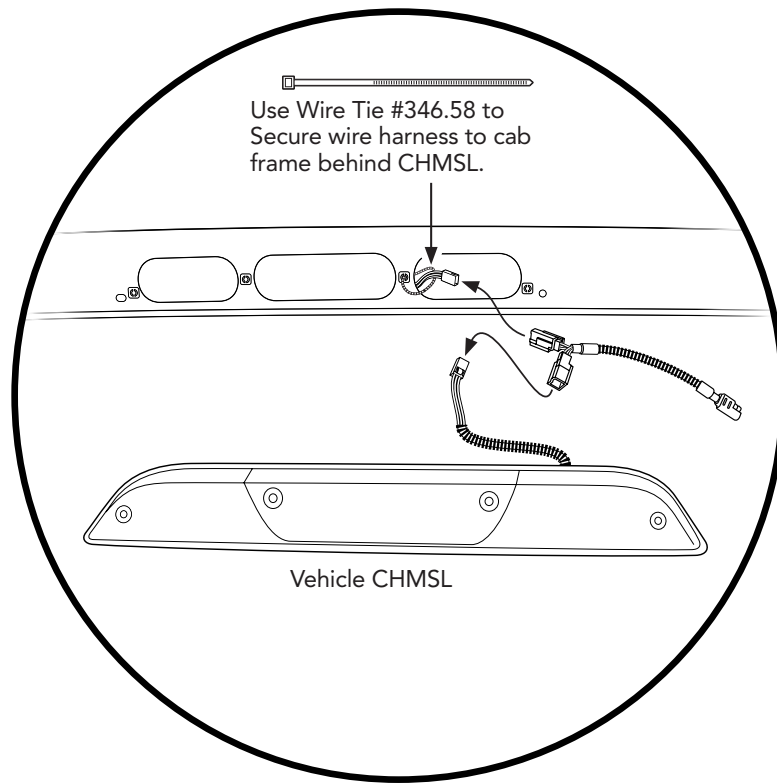

Use Wire Tie #346.58 to Secure wire harness to cab frame behind CHMSL.

Vehicle CHMSL

Step 2

Unplug the connector between the CHMSL and the wire harness that goes through the vehicle cab where the CHMSL was removed.

Plug both connectors on the Patch Loom into the connectors that you just unplugged coming from the vehicle CHMSL harness.

Use Wire Tie #346.58 to Secure the wire harness to the cab frame behind the CHMSL.

Step 1

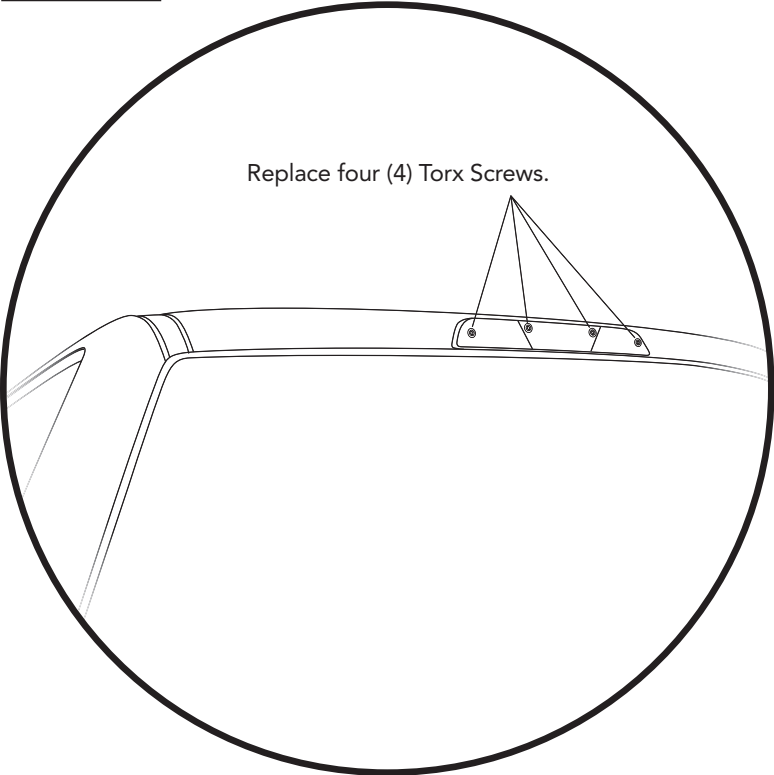

Tools



T20 Torx Driver

Step 1

Find the four (4) T20 Torx screws you removed earlier, and re-attach the Center High-Mounted Stop Light (CHMSL) to the vehicle cab.

Step 1

Detail

Step 2

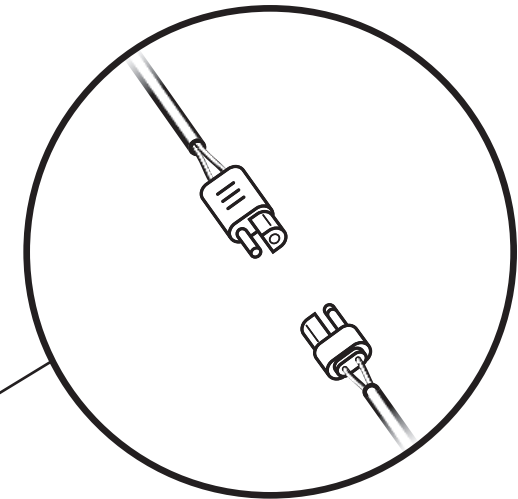
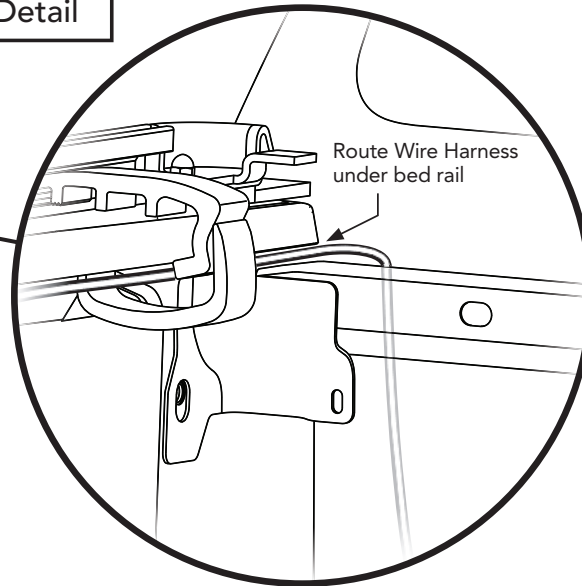
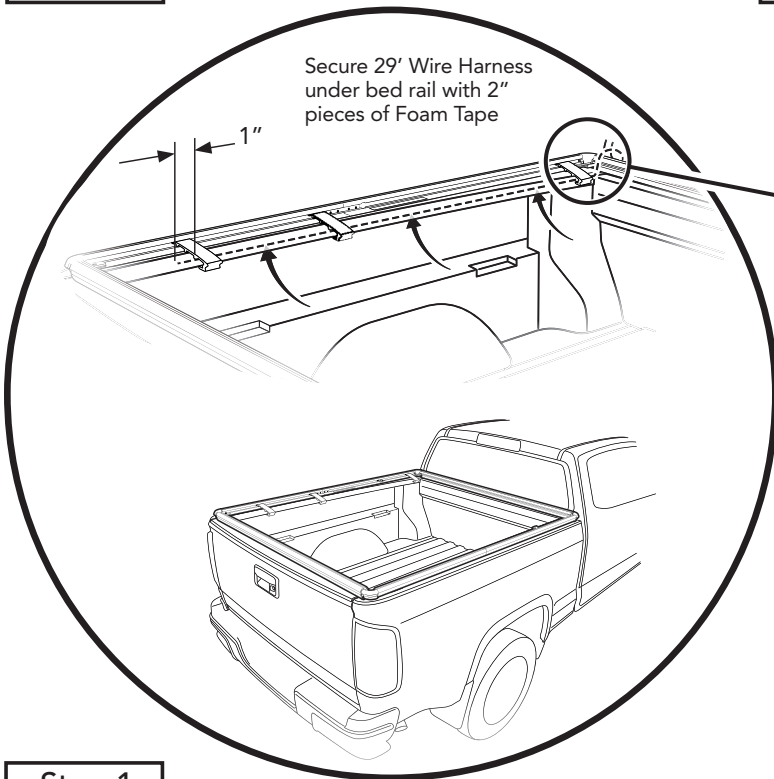

Hardware



Foam Tape
Part #595.31
2" Pieces

Step 1

Route the 29' Wire Harness from the front of the vehicle bed to the rear, underneath the bed rail, and through each of the three clamps. (See Detail) Attach the wire to the underside of the bed rail using 2" pieces of the Foam Tape #593.51. Run the wire to just 1" past the rear clamp.

Step 2

routing the 29' Wire Harness, plug the 2-conductor connectors at the ends of the CHMSL Wire Harness and the 29' Wire Harness together.

NOTE: You must unplug these connectors before folding the top down.

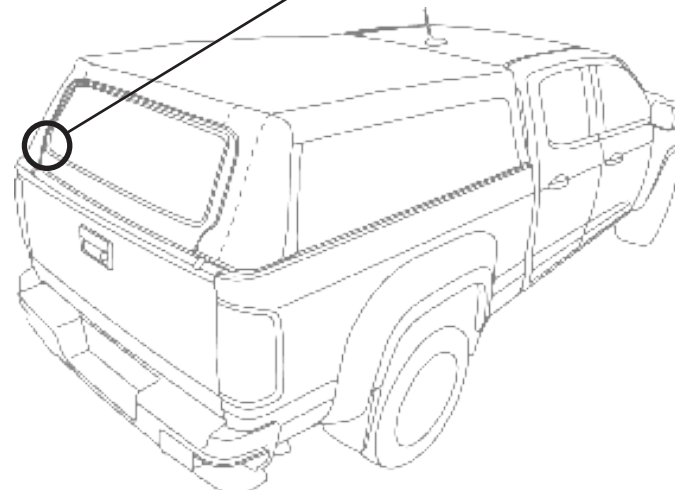

Step 1

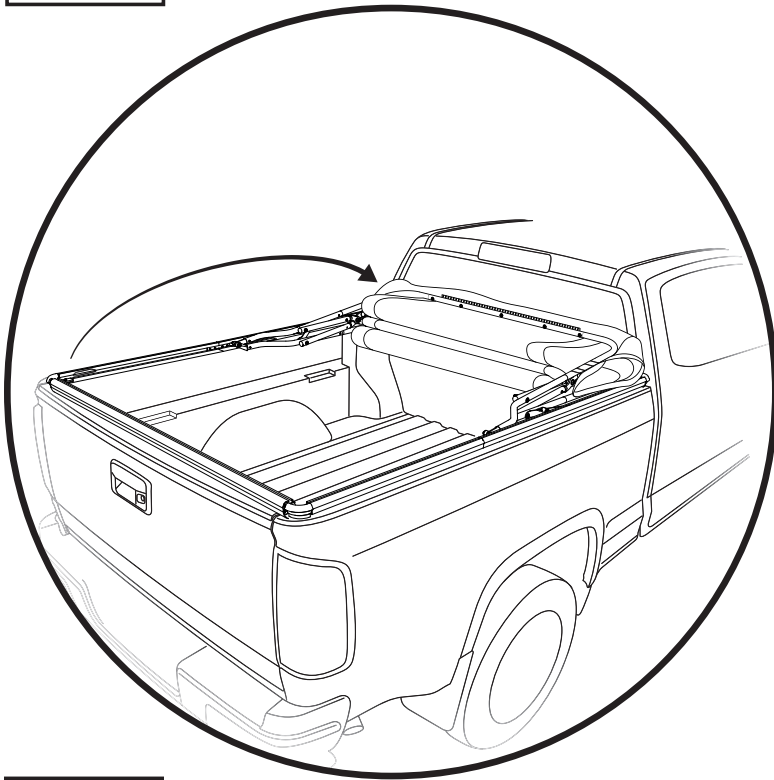

Step 1

To open the top:

- Unzip and remove Side Curtains.
- Unzip and remove Rear Window.
- Release plastic tabs from rails all around.
- Flip rear corners of top fabric up onto roof.
- Fold the top forward so that all the bows collapse and rest on the Front Rail.

Step 2

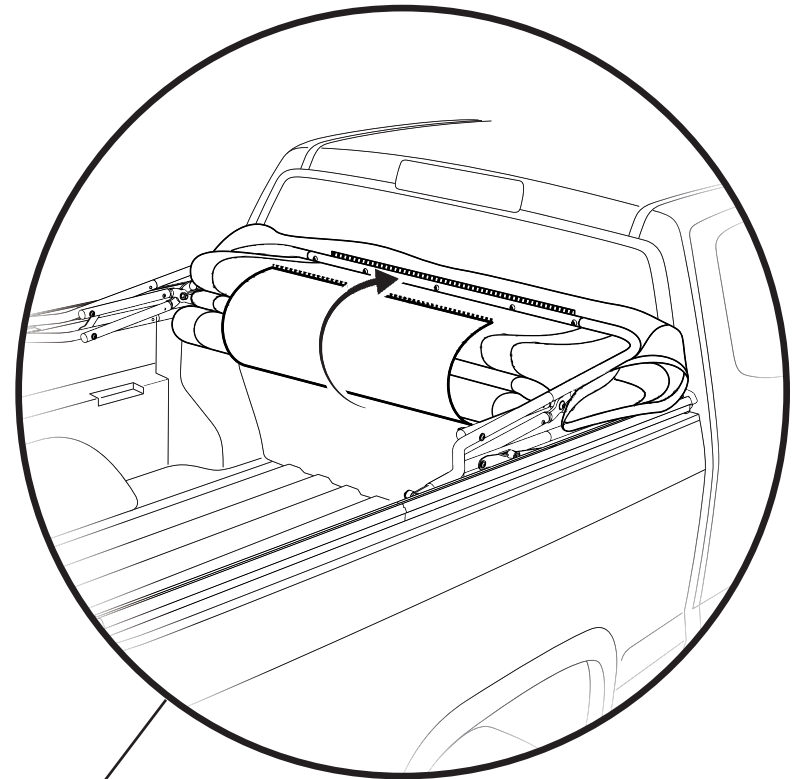

Step 2

Protect the top fabric by wrapping the Boot attached to the Front Window around the Fabric and Bows.

Secure the Boot by zipping it to the zipper for the Rear Window.

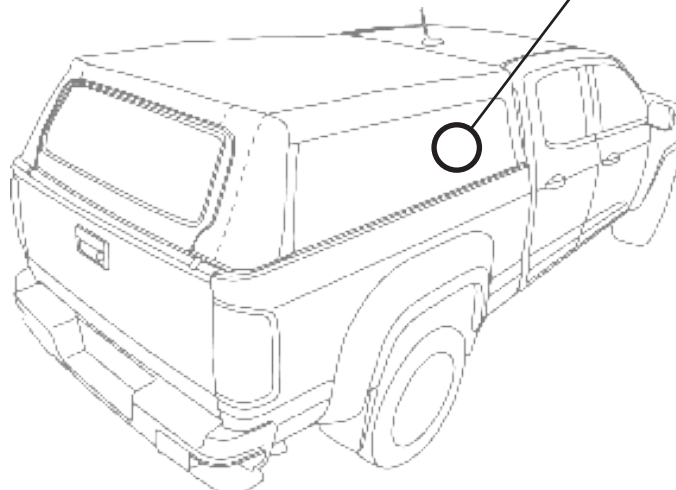

Step 1

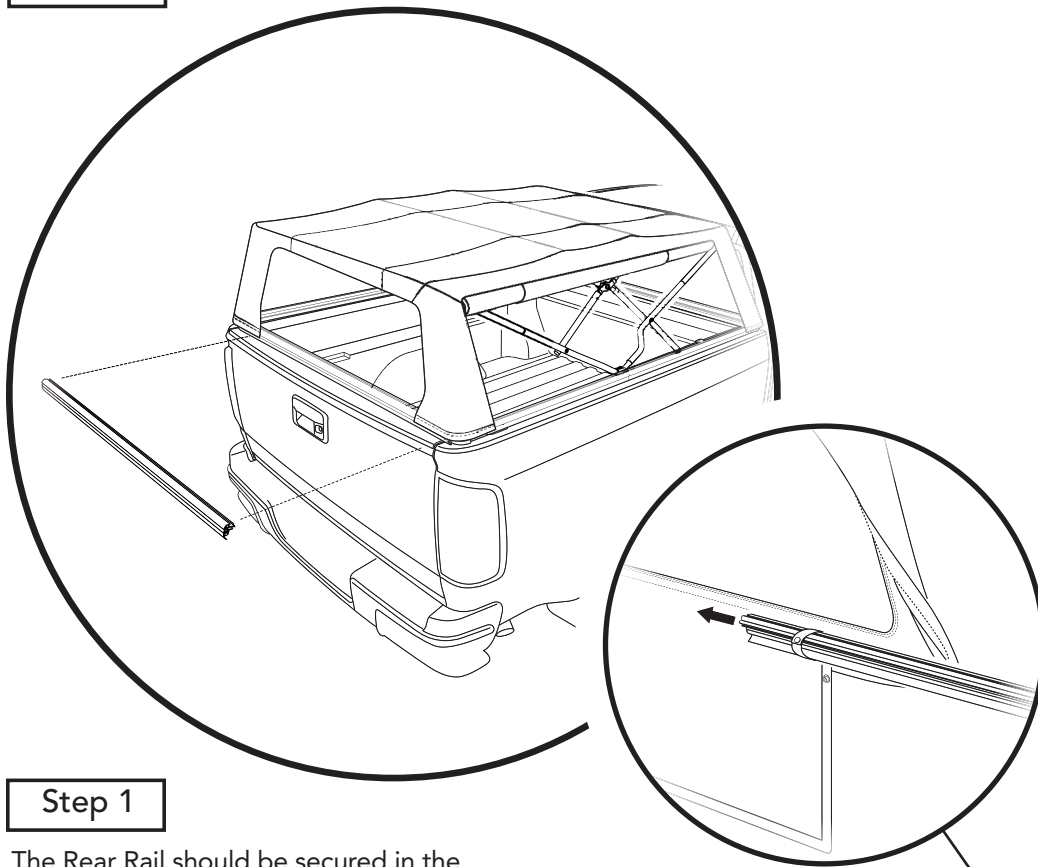

Step 1

The Rear Rail should be secured in the straps at the bottom of the Front Window when the top is folded down.

Wrap the straps around the Rear Rail and snap closed.

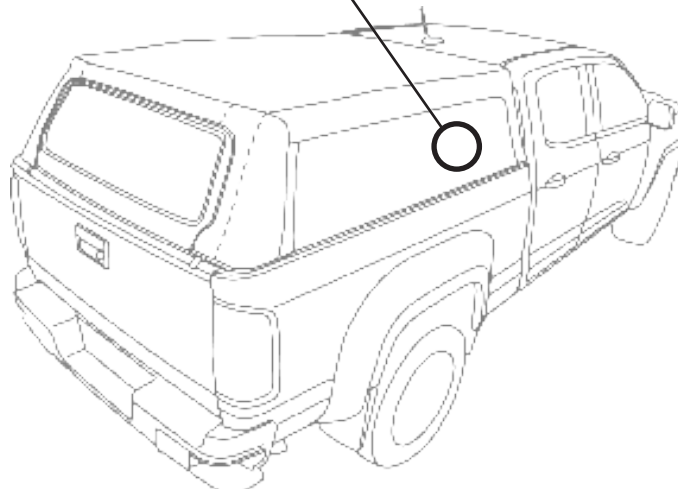

Step 1

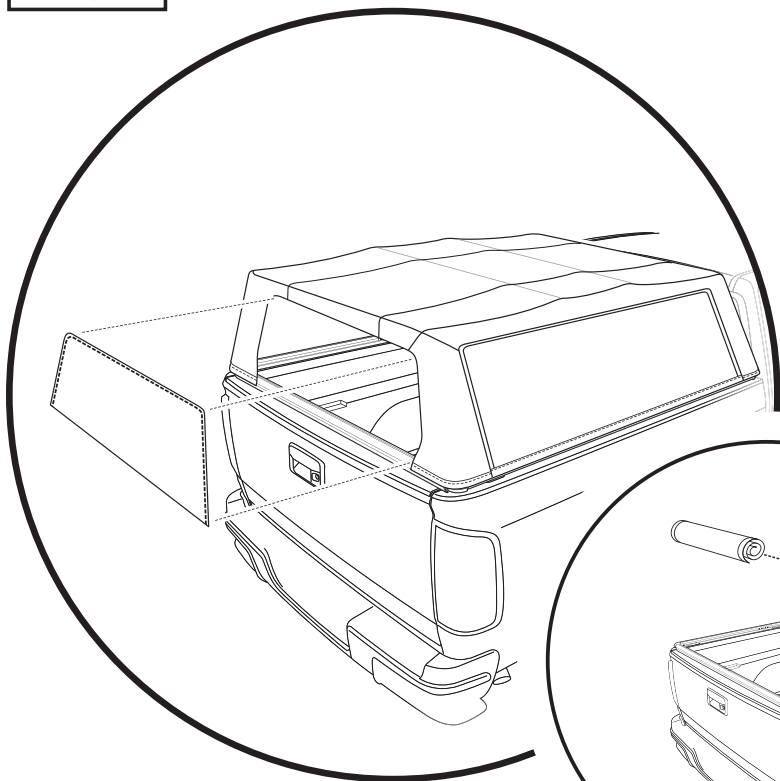

Step 1

With the Fabric Top up, the Rear Window can be stored in the Boot attached to the bottom of the Front Window.

Place the rolled-up Rear Window in the Boot, and zip the Boot closed.

Step 2

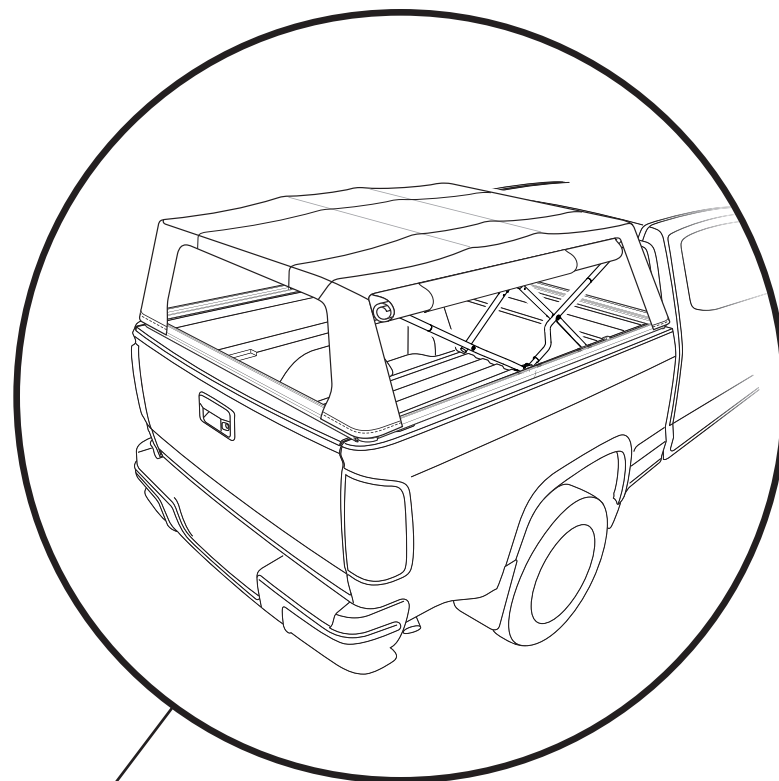

Step 2

With the Fabric Top up, the Side Curtains can be rolled up and secured with attached side flaps.

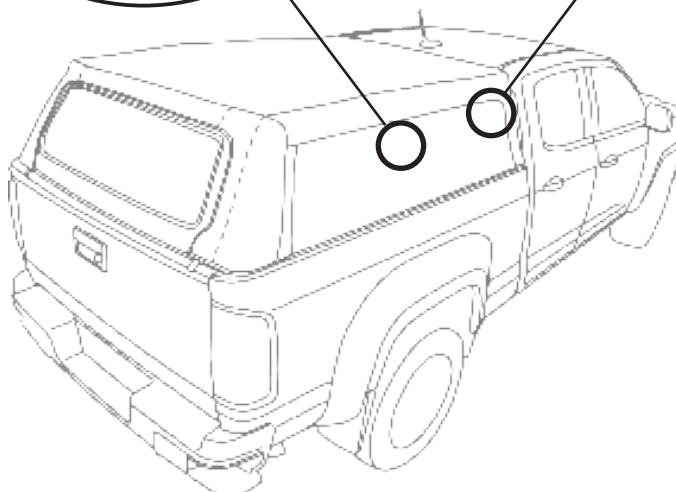



Warranty Information Supertop for Trucks

Vehicle Application:
Ford F-150 2015-Current 6.5' Bed
Part Number 77336

WHAT BESTOP WARRANTS

Subject to the terms and conditions of sale, including any terms and conditions set forth by Bestop, Inc. (“Bestop” or “us” or “we”) in our then-current terms of sale on our website (collectively, the “Terms”), Bestop represents and warrants that: the covered products listed in the “Covered Products and Warranty Periods” section (a “Product”) will substantially be free from defects in materials and workmanship for the specified warranty periods set forth in that section.

THE WARRANTY IS LIMITED AND CONDITIONAL

This warranty applies to the original purchaser of the Product only. The warranty is valid only as long as the original retail purchaser owns the vehicle upon which the Product is installed. The warranty expires should the Product be removed from the original vehicle or if the original vehicle is transferred to another owner. This warranty is not transferable or assignable. The warranty does not apply to Product bought from auction-style or price-bid websites.

THE LIMITED WARRANTY AND STATED REMEDIES ARE SOLE AND EXCLUSIVE AND IN LIEU OF ALL OTHER WARRANTIES AND REMEDIES, AND COMPANY EXPRESSLY DISCLAIMS ALL IMPLIED OR STATUTORY OR OTHER WARRANTIES, INCLUDING WITHOUT LIMITATIONS WARRANTIES OF MERCHANTABILITY, NON-INFRINGEMENT OR FITNESS FOR A PARTICULAR PURPOSE. IN NO EVENT WILL COMPANY BE LIABLE FOR ANY SPECIAL, INCIDENTAL, CONSEQUENTIAL, PUNITIVE, INDIRECT OR EXEMPLARY DAMAGES OF ANY KIND, INCLUDING LOST PROFITS OR REVENUE, HOWEVER CAUSED, WHETHER FOR BREACH OR REPUDIATION OF CONTRACT, TORT, BREACH OF WARRANTY, NEGLIGENCE, OR OTHERWISE, WHETHER OR NOT COMPANY WAS ADVISED OF THE POSSIBILITY OF SUCH LOSS OR DAMAGES.

Some states do not allow exclusion or limitation, so this may not apply to you. This warranty gives you specific legal rights, and you may have other rights which vary from state to state.

EXCLUSIONS TO THE WARRANTY

The Limited Warranty excludes, and Bestop is not liable in any way for any warranty claims, damages, or defects related to:

- Misuse, abuse, accidents, vandalism, negligence, fire, or improper installation or modification, or improper or inadequate maintenance;
- Failure to comply with any Product documentation, Bestop instructions, or applicable law or regulations; use in extreme conditions
- Force Majeure including but not limited to, earthquake, hurricane, tornado, flooding, or other disasters natural or man-made, civil unrest, strikes, declared or undeclared war, or lack of performance by, or discontinued product of, supply chain partners whose products, software, operations or management is beyond the control of Bestop;
- Damage resulting in breakage (including without limitation, spontaneous breakage, accidental breakage or breakage by any other means) of a Product or any component part;
- Damage to vinyl windows due to misuse, or cracking due to varying weather conditions.

YOUR SOLE REMEDY

During the applicable warranty period, Bestop shall, at its option, either repair or replace any Product that it confirms, in its discretion, is non-compliant with the warranties herein. Bestop will not pay for labor charges associated with installation or removal of the Product. Should a specific Product be discontinued, Bestop may, at its option, replace the discontinued Product with a current product or like product.

Please retain your proof of purchase. Original proof of purchase for the Product must accompany any warranty claim. If you have a warranty claim, first you must email Bestop Customer Service at csbestop@bestop.com for instructions. All claims must be emailed to csbestop@bestop.com within 30 days of discovery of a defective Product, but in no event later than thirty days after the end of the applicable Warranty Period (the “Warranty Notice Period”). Warranty claims made after the Warranty Notice Period are null and void and Bestop shall have no responsibility with respect to such claims.

THIS SECTION SETS FORTH BESTOP’S SOLE OBLIGATION & YOUR SOLE REMEDY WITH RESPECT TO ANY DEFECTS OR OTHER PRODUCT ISSUE. ANY PRODUCTS REPLACED UNDER TERMS OF THIS WARRANTY WILL BE COVERED UNDER TERMS & BALANCE OF THE DURATION OF THE ORIGINAL LIMITED WARRANTY FOR SUCH PRODUCT.



Warranty Information Supertop for Trucks

Vehicle Application:
Ford F-150 2015-Current 6.5' Bed
Part Number 77336

COVERED PRODUCTS AND WARRANTY PERIODS: The warranty time periods are as follows for Products manufactured by Bestop:

BESTOP® LIMITED LIFETIME WARRANTY

Trektop® Pro Twill Fabric Top Sunrider® for Hardtop Twill Fabric Top
Trektop® NX Glide Twill Fabric Top Replace-a-Top™ Twill Fabric Top
Trektop® NX Twill Fabric Top Supertop® NX Twill Fabric Top
EZFold™ Soft Tonneaus Floor & Cargo Liners
ZipRail™ Soft Tonneaus Pet Barriers
EZRoll™ Soft Tonneaus

BESTOP® 5-YEAR LIMITED WARRANTY

Trektop® NX Glide™ Top (non-Twill) Sunrider® for Hardtop (non-Twill) Replace-a-Top™ Top (non-Twill) Trektop® NX Top (non-Twill)
Sailcloth Replace-a-Top™ Supertop® NX Top (non-Twill)
Tigertop™ and Halftop™ Supertop® Classic Soft Top Sunrider® Complete Soft Top Supertop® for Truck
EZ Fold Hard Tonneau

BESTOP® 3-YEAR/100K MILES LIMITED WARRANTY

Powerboard® & Powerboard® NX
Trekstep®, Side Mount
Trekstep®, Rear Mount

BESTOP® 3-YEAR LIMITED WARRANTY

Pavement Ends Sprint Top

BESTOP® 2-YEAR LIMITED WARRANTY

Trektop® Classic Soft Top
RoughRider™ Soft Storage

BESTOP® 1-YEAR LIMITED WARRANTY

All other Bestop® & Pavement Ends™ products not specified above.

For further information or request for warranty work, please contact:

Bestop Inc. Customer Service
Toll-Free: (800)845-3567
Main: (303)465-1755
E-mail: csbestop@Bestop.com
Website: www.Bestop.com

This product may be covered by 1 or more patents or pending applications, information can be found at www.bestop.com/patents