



# Installation Instructions Supertop for Truck2 Tonneau

Vehicle Application:  
TOYOTA TACOMA 5' bed, 16 -Current  
Part Number 77408

## Installation Tips

Before you begin installing your new Supertop2 Tonneau, please read all the instructions thoroughly.

Note: A Supertop for Truck is required to install Tonneau.

For a smooth fit:

For easier installation, the top should be installed at a temperature above 72° F. Below this temperature, the fabric may contract an inch or more, making it difficult to fit the vehicle. You may let the fabric sit in the sun for 15-20 minutes before installing to let the fabric warm up.

It is normal for the fabric to contract and wrinkle when stored in the shipping carton. Within a few days after installation, the fabric will relax and the wrinkles will disappear.

**WARNING** Do not rely in any way on the components of this product to protect against injury or death in the event of an accident. Never operate the vehicle in excess of manufacturer's specifications.

Read and follow, precisely, all installation instructions provided when installing this product. Failure to do so may result in a poor fit and could place occupants of the vehicle in a potentially dangerous situation.

**CAUTION** Safety glasses should be worn at all times when installing this product.

**WEAR SEAT BELTS AT ALL TIMES**

## Tools

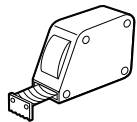

Tape Measure

## Installation Time

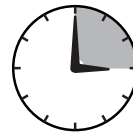

15 Minutes

## Skill Level



3 -Easy

## Support

We're here to help! Go to:  
<https://www.bestop.com>  
and click on Need Help?



<https://www.bestop.com/video-library>



## Installation Instructions Supertop for Truck2 Tonneau

Vehicle Application:  
TOYOTA TACOMA 5' bed, 16 -Current  
Part Number 77408

### Sugerencias de Instalación

**Antes de empezar a instalar esta unidad, lea atentamente todas las instrucciones.**

**Para un buen ajuste:**

Para facilitar la instalación, el producto debe instalarse a temperaturas superiores a 72 °F (22 °C).

Por debajo de esta temperatura, la tela puede encogerse una pulgada o más, lo que dificultaría su ajuste al vehículo.

Es normal que la tela se contraiga o arrugue cuando está guardada en la caja de empaque. A los pocos días después de la instalación, la tela se relajará y las arrugas desaparecerán.



#### ADVERTENCIA

Este producto se diseñó principalmente para mejorar la apariencia del vehículo y proteger a los ocupantes de las condiciones climáticas comunes. De ninguna manera piense que los componentes de este producto pueden servir como medio de contención para los ocupantes del vehículo o que pueden protegerlos contra lesiones o la muerte en caso de accidente. Este producto no protegerá a los ocupantes contra caídas de objetos. Nunca conduzca este vehículo fuera de las especificaciones del fabricante.

#### USE LOS CINTURONES DE SEGURIDAD EN TODO MOMENTO

Lea y siga con precisión todas las instrucciones de instalación que se proporcionan para instalar este producto. Si no lo hace, podría producirse un mal ajuste que colocaría a los ocupantes del vehículo en una situación potencialmente peligrosa.



#### PRECAUCIÓN

Debe usar gafas protectoras en todo momento durante la instalación de este producto.

### Conseils pour l'installation

**Lire toutes les instructions au complet avant de commencer l'installation de cet assemblage.**

**Pour un ajustement sans problème :**

Afin de faciliter l'installation, ce produit doit être installé à des températures au-dessus de 72 °F (22 °C).

Sous cette température, le tissu peut rétrécir d'un pouce (2,5 cm) ou plus, ce qui rendra l'ajustement sur le véhicule difficile.

Il est normal que le tissu rétrécisse et plisse pendant qu'il est dans la boîte d'expédition. En quelques jours après l'installation, le tissu se détendra et les plis disparaîtront.



#### AVERTISSEMENT

Ce produit est conçu principalement pour améliorer l'apparence du véhicule et pour protéger les occupants des conditions météorologiques usuelles. Ne jamais se fier aux composants de ce produit pour se protéger de blessures ou de la mort en cas d'accident. Ce produit ne protégera pas les occupants des chutes d'objets. Ne jamais utiliser le véhicule au-delà des caractéristiques techniques indiquées par le fabricant.

#### PORTER UNE CEINTURE DE SÉCURITÉ EN TOUT TEMPS

Lire et suivre, très fidèlement, toutes les instructions d'installation fournies lors de l'installation de ce produit. Ne pas suivre cette consigne peut causer une installation inadéquate et mettre les occupants du véhicule dans une situation potentiellement dangereuse.



#### MISE EN GARDE

Des lunettes de sécurité doivent être portées en tout temps lors de l'installation de ce produit.



# Installation Instructions Supertop for Truck2 Tonneau

Vehicle Application:  
TOYOTA TACOMA 5' bed, 16 -Current  
Part Number 77408

## Parts list:

Cover Assembly  
Part #77408B35  
qty 1

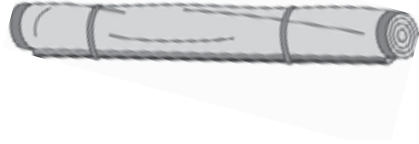

**NOTE:** Before beginning installation of tonneau, verify measurements of frame. Between front edge of side rails, measurement should be 58 5/16". Between rear edge of side rails, measurement should be 56"

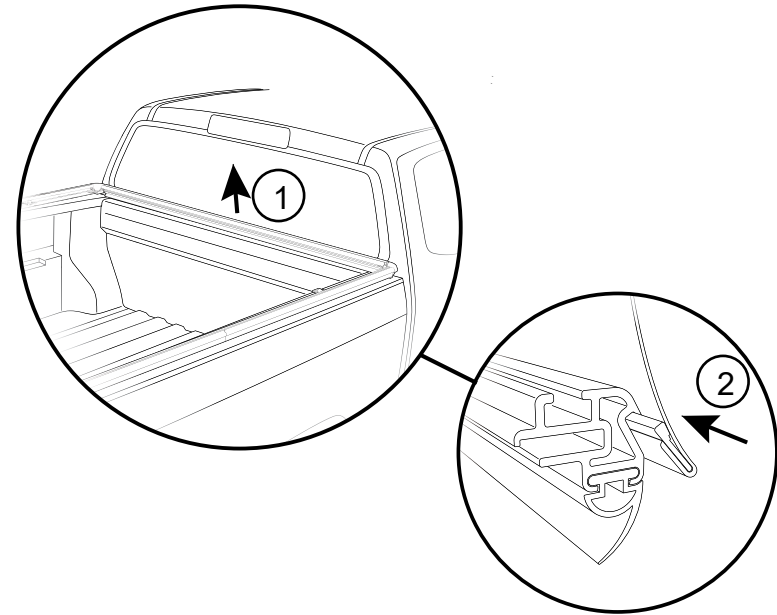
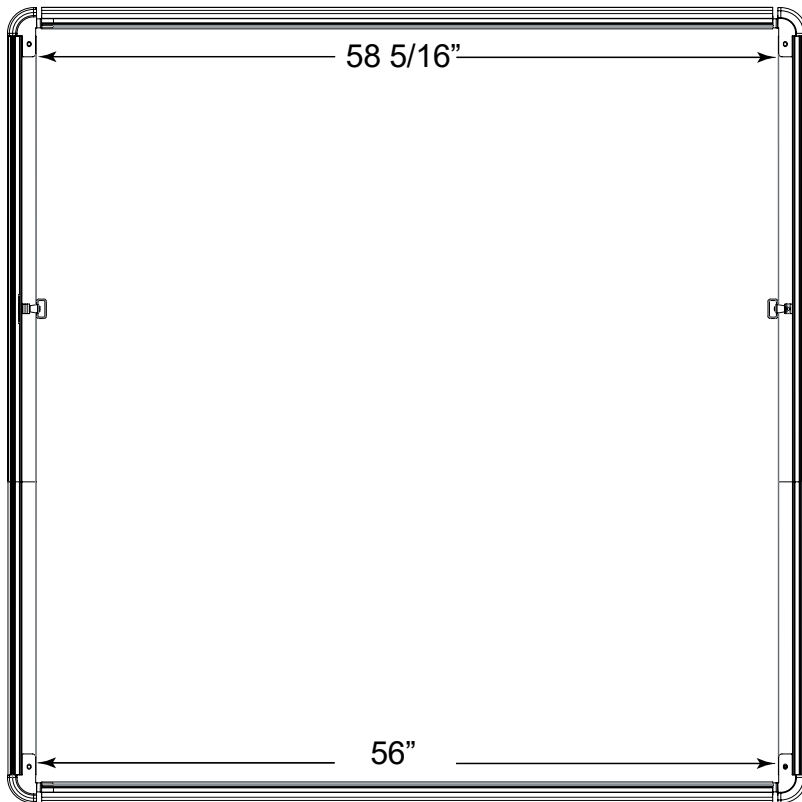

## Step 1 Attach cover to front rail

Remove front rail (1), then slide the plastic strip located on the front of tonneau onto the rail (2)



# Installation Instructions Supertop for Truck2 Tonneau

Vehicle Application:  
TOYOTA TACOMA 5' bed, 16 -Current  
Part Number 77408

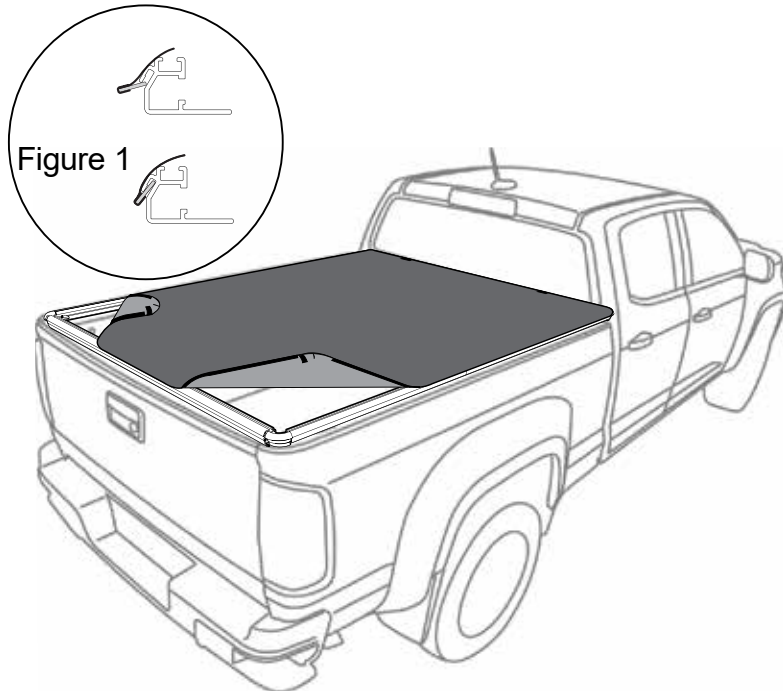

## Step 4: Install cover

Check that the front strip on the Tonneau Fabric is centered in the Front Rail. If not slide the strip in the rail until it is centered. The plastic strips along the three sides of the vinyl cover fit into the grooves in the rail assembly.

Unfasten the tie-down straps, then roll out the cover to the rear of the truck. Center the cover above the tailgate latch and begin inserting the rear plastic strip into the groove (see Figure 1). Working from the center out to each rear corner. Use one hand to insert and the other to guide the plastic into the groove.

Start at either the front or rear corner to insert the side plastic strip into the groove. Work to the opposite corner. Repeat on both sides.

**Note:** If cover feels loose on one side or the other, the cover is not centered properly. Pull cover off of rails, re-center the cover on the rear rail and proceed to insert the strips into the rails.

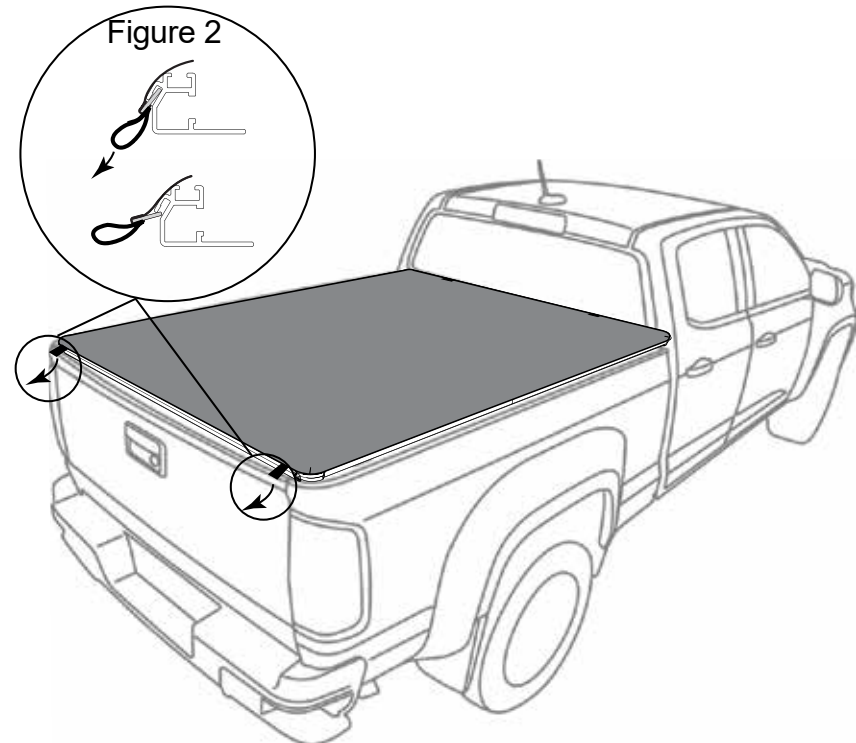

## Step 5: Cover removal

To remove cover:

Use the loops at the Right or Left rear corner and ease the plastic strip out of the rail by pulling **DOWN** and **OUT** (See Figure 2). Then peel the plastic strip out of the remainder of the rear rail.

Pull **DOWN** and **OUT** on the vinyl fabric to remove the plastic strips from the sides of the rail assembly. Roll cover toward cab of truck. Use Hook & Loop straps attached to front of rail to secure cover.

To fasten cover, repeat installation step 4.



## Installation Instructions Supertop for Truck2 Tonneau

Vehicle Application:  
TOYOTA TACOMA 5' bed, 16 -Current  
Part Number 77408

### WHAT BESTOP WARRANTS

Subject to the terms and conditions of sale, including any terms and conditions set forth by Bestop, Inc. ("Bestop" or "us" or "we") in our then-current terms of sale on our website (collectively, the "Terms"), Bestop represents and warrants that: the covered products listed in the "Covered Products and Warranty Periods" section (a "Product") will substantially be free from defects in materials and workmanship for the specified warranty periods set forth in that section.

### THE WARRANTY IS LIMITED AND CONDITIONAL

This warranty applies to the original purchaser of the Product only. The warranty is valid only as long as the original retail purchaser owns the vehicle upon which the Product is installed. The warranty expires should the Product be removed from the original vehicle or if the original vehicle is transferred to another owner. This warranty is not transferable or assignable. The warranty does not apply to Product bought from auction-style or price-bid websites.

THE LIMITED WARRANTY AND STATED REMEDIES ARE SOLE AND EXCLUSIVE AND IN LIEU OF ALL OTHER WARRANTIES AND REMEDIES, AND COMPANY EXPRESS DISCLAIMS ALL IMPLIED OR STATUTORY OR OTHER WARRANTIES, INCLUDING WITHOUT LIMITATIONS WARRANTIES OF MERCHANTABILITY, NON-INFRINGEMENT OR FITNESS FOR A PARTICULAR PURPOSE. IN NO EVENT WILL COMPANY BE LIABLE FOR ANY SPECIAL, INCIDENTAL, CONSEQUENTIAL, PUNITIVE, INDIRECT OR EXEMPLARY DAMAGES OF ANY KIND, INCLUDING LOST PROFITS OR REVENUE, HOWEVER CAUSED, WHETHER FOR BREACH OR REPUDIATION OF CONTRACT, TORT, BREACH OF WARRANTY, NEGLIGENCE, OR OTHERWISE, WHETHER OR NOT COMPANY WAS ADVISED OF THE POSSIBILITY OF SUCH LOSS OR DAMAGES.

Some states do not allow exclusion or limitation, so this may not apply to you. This warranty gives you specific legal rights, and you may have other rights which vary from state to state.

### EXCLUSIONS TO THE WARRANTY

The Limited Warranty excludes, and Bestop is not liable in any way for any warranty claims, damages, or defects related to:

- Misuse, abuse, accidents, vandalism, negligence, fire, or improper installation or modification, or improper or inadequate maintenance;
- Failure to comply with any Product documentation, Bestop instructions, or applicable law or regulations; use in extreme conditions
- Force Majeure including but not limited to, earthquake, hurricane, tornado, flooding, or other disasters natural or man-made, civil unrest, strikes, declared or undeclared war, or lack of performance by, or discontinued product of, supply chain partners whose products, software, operations or management is beyond the control of Bestop;
- Damage resulting in breakage (including without limitation, spontaneous breakage, accidental breakage or breakage by any other means) of a Product or any component part;
- Damage to vinyl windows due to misuse, or cracking due to varying weather conditions.

### YOUR SOLE REMEDY

During the applicable warranty period, Bestop shall, at its option, either repair or replace any Product that it confirms, in its discretion, is non-compliant with the warranties herein. Bestop will not pay for labor charges associated with installation or removal of the Product. Should a specific Product be discontinued, Bestop may, at its option, replace the discontinued Product with a current product or like product.

Please retain your proof of purchase. Original proof of purchase for the Product must accompany any warranty claim. If you have a warranty claim, first you must email Bestop Customer Service at [csbestop@bestop.com](mailto:csbestop@bestop.com) for instructions. All claims must be emailed to [csbestop@bestop.com](mailto:csbestop@bestop.com) within 30 days of discovery of a defective Product, but in no event later than thirty days after the end of the applicable Warranty Period (the "Warranty Notice Period"). Warranty claims made after the Warranty Notice Period are null and void and Bestop shall have no responsibility with respect to such claims.

THIS SECTION SETS FORTH BESTOP'S SOLE OBLIGATION & YOUR SOLE REMEDY WITH RESPECT TO ANY DEFECTS OR OTHER PRODUCT ISSUE. ANY PRODUCTS REPLACED UNDER TERMS OF THIS WARRANTY WILL BE COVERED UNDER TERMS & BALANCE OF THE DURATION OF THE ORIGINAL LIMITED WARRANTY FOR SUCH PRODUCT.



## Installation Instructions Supertop for Truck2 Tonneau

Vehicle Application:  
TOYOTA TACOMA 5' bed, 16 -Current  
Part Number 77408

COVERED PRODUCTS AND WARRANTY PERIODS: The warranty time periods are as follows for Products manufactured by Bestop:

### BESTOP® LIMITED LIFETIME WARRANTY

Trektop® Pro Twill Fabric Top Sunrider® for Hardtop Twill Fabric Top  
Trektop® NX Glide Twill Fabric Top Replace-a-Top™ Twill Fabric Top  
Trektop® NX Twill Fabric Top Supertop® NX Twill Fabric Top  
EZFold™ Soft Tonneaus Floor & Cargo Liners  
ZipRail™ Soft Tonneaus Pet Barriers  
EZRoll™ Soft Tonneaus

### BESTOP® 5-YEAR LIMITED WARRANTY

Trektop® NX Glide™ Top (non-Twill) Sunrider® for Hardtop (non-Twill) Replace-a-Top™ Top (non-Twill) Trektop® NX Top (non-Twill)  
Sailcloth Replace-a-Top™ Supertop® NX Top (non-Twill)  
Tigertop™ and Halftop™ Supertop® Classic Soft Top Sunrider® Complete Soft Top Supertop® for Truck  
EZ Fold Hard Tonneau

### BESTOP® 3-YEAR/100K MILES LIMITED WARRANTY

Powerboard® & Powerboard® NX  
Trekstep®, Side Mount  
Trekstep®, Rear Mount

### BESTOP® 3-YEAR LIMITED WARRANTY

Pavement Ends Sprint Top

### BESTOP® 2-YEAR LIMITED WARRANTY

Trektop® Classic Soft Top  
RoughRider™ Soft Storage

### BESTOP® 1-YEAR LIMITED WARRANTY

All other Bestop® & Pavement Ends™ products not specified above.

For further information or request for warranty work, please contact:

Bestop Inc. Customer Service

Toll-Free: (800)845-3567

Main: (303)465-1755

E-mail: [csbestop@Bestop.com](mailto:csbestop@Bestop.com)

Website: [www.Bestop.com](http://www.Bestop.com)

This product may be covered by 1 or more patents or pending applications, information can be found at [www.bestop.com/patents](http://www.bestop.com/patents)