

HARDWARE DESCRIPTION		QTY.
HWKT-00423X		
CLIP-00647	3/8"-16 X 1 3/4" BARREL NUT CLIP	14
FDRW-00736	M8 FENDER WASHER	12
FLTW-00663X	3/8" USS FLAT WASHER ZINCLAD 1000B	14
HHCS-00685	3/8"-16X 1-1/2" HEX CAP SCREW	14
LCKW-00722	M8 SPLIT LOCK WASHER	12
HHCS-00649	M8-1.25X35MM HEX CAP SCREW	12

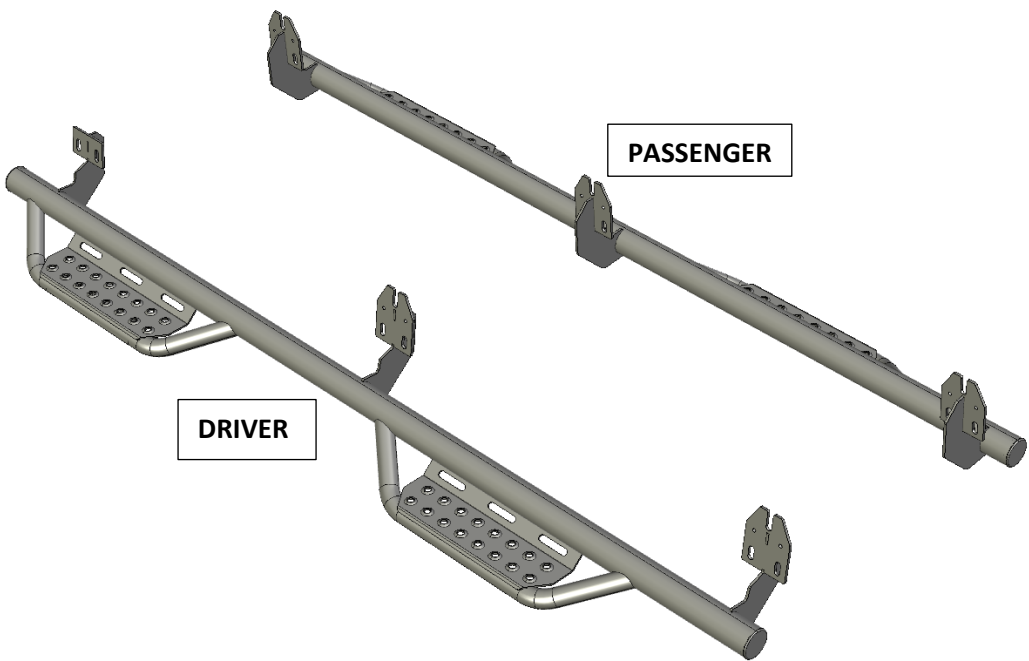

PARTS INCLUDED		QTY
DRIVER SIDE		1
PASSENGER SIDE		1

Step 1: Identify Driver side step



Step 2: Beginning with the driver's side; locate the six sets factory mounting hex holes (3 on each side of the vehicle). These are positioned on the vertical sides of the floor pan beneath the doors, with one set of holes each in the front, middle, and rear of the vehicle cab.

Step 3: If you have a 14-18 model you may have to drill a 1" round opening for the rear bracket location to add the second clip. If so, go ahead and complete this step at his time.

Step 4: Using the 3/8" threaded clips, slide two clips in the upper rectangular hole, and align one clip in each hex hole so the clip threads are visible.

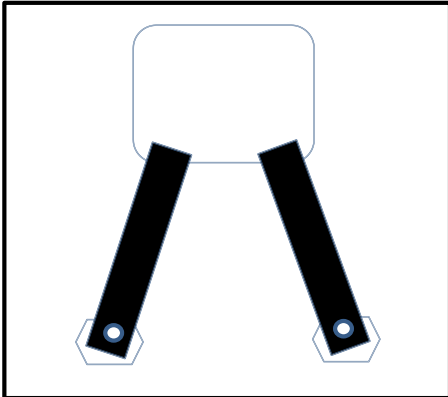

Figure 1: 09 - 14 RAM 1500, 2500, 3500, exc. 2014 1500 Quad Cab

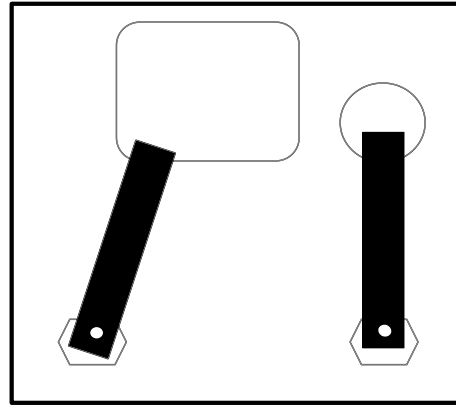

Figure 2: 2014 RAM 1500 Quad Cab, rear mounting locations

NOTE: On 2014 Quad Cab models in the rear mounting location, the hex holes are offset and only the forward mounting hole and clip are used. If desired, the rear clip may be used by cutting a 1" hole directly above the rear hex hole, and level with the lower edge of the upper rectangular as shown by the dotted diagrams in **figure 2**.

Step 5: Align the Nerf Step brackets with the three mounting locations on the underside of the vehicle. Start all six 3/8" x 1" hex bolts with washers and leave loose.

Step 6: Using a sharpie, outline the upper "U" shaped mount in the center bracket



Step 7: Remove Nerf Step and set aside. Next, slide the additional 3/8 threaded clip from the upper rectangle hole and align with the “U” shaped mark from step 5. Make a mark through the threaded part of the clip.



Step 8: Remove clip. Use a 1/2” drill bit and drill out the center mark. Slide the 3/8 clip back into position so the threaded part is aligned with the hole.

Step 9: Repeat Step 5 with the additional upper clip. Starting with the rear Bracket, raise the Nerf step into position and torque the bolts to 15-20 ft./lbs. Move to the front bracket and torque bolts. Then to the center brackets and torque down bolts. (**NOTE:** There are two additional mounting points in each bracket for a 5/16 self tapper or rivet for upper impacts situations. Self tapper and rivets not included.)

Step 10: Repeat Steps 2-9 for passenger side.